

# Identifying Airide™ springs

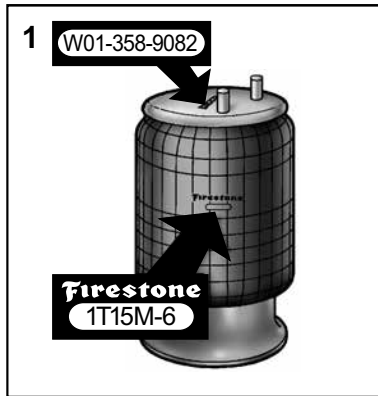

## 1. Read AON and bellows number.

The first step to identifying an Airide™ spring for replacement is to read the assembly order number on the label adhered to the bead plate (i.e., W01-358-9082). If the number is illegible, read the bellows number which is normally molded directly underneath the Firestone logo. A style number such as 1T15M-6 or 22 would tell exactly which bellows is needed and one could skip steps 2 and 3.

If the bellows number is illegible, then determine whether it is a convoluted style or a 1T style by comparing it to the pictures in this guide. Proceed to step 2 if 1T style or step 3 if convoluted.

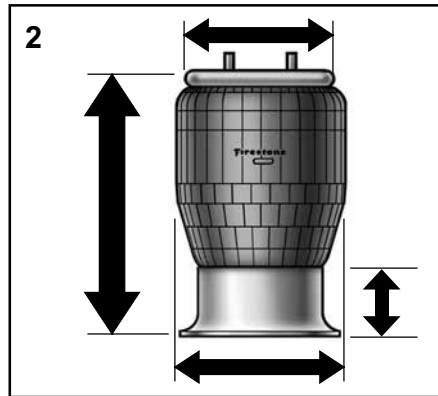

## 2. 1T Style

Measure the bead plate diameter and molded (**uninflated**) diameter of the rubber bellows and compare this with the 1T styles in the bellows index until a match is found (please note that the molded diameter can grow slightly with years of service). Then measure from the bottom of the piston to the top of the bead plate while the part is **uninflated** and **extended**. Next, find this same or similar measurement in the specific bellows section that was previously determined. When this has been done, skip to step 4. If the piston number is illegible in step 5, measure the piston height and compare it to pictures with the same dimensions.

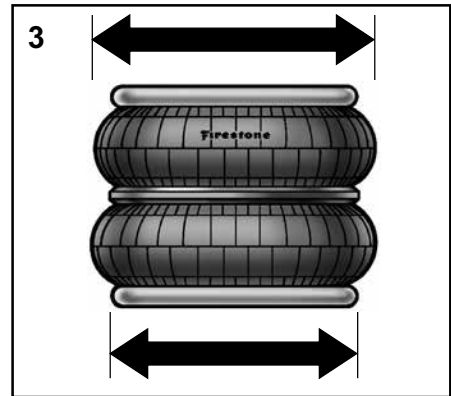

## 3. Convoluted style

First determine whether it is a single, double, or triple convoluted style by comparing it to the pictures in this guide. Then measure the bead plate diameter and the diameter of the bellows (**uninflated**) across its widest area and compare these dimensions with those given in the bellows index. Once a match has been made, proceed to step 4.

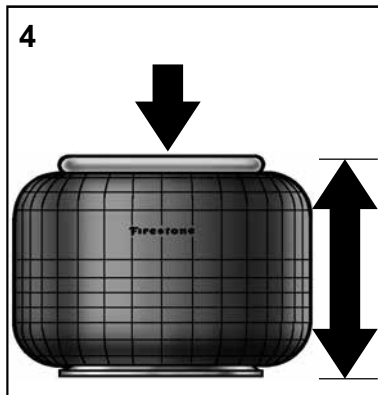

## 4. Rubber Bumper

Many Airide™ springs include a rubber bumper inside the spring. To determine if one is present, compress the spring to its minimum height and measure from the bottom plate or piston to the top of the bead plate.

Compare this compressed height with the pictures in the appropriate bellows section that was determined in step 2 (1T style) or step 3 (convoluted style). Proceed to step 5 if you have a 1T style spring or step 6 if you have a convoluted spring.

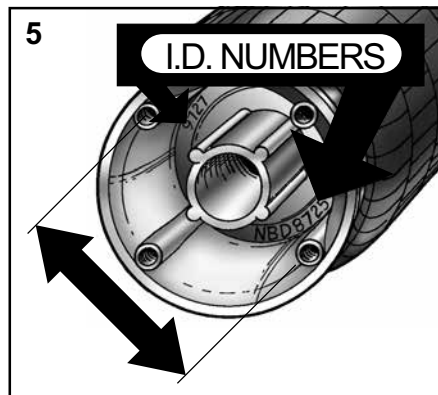

## 5. 1T style (bead plate and piston)

The same bellows is used with many different combinations of bead plates and pistons, so be sure to check closely. Compare the bead plate and piston with the pictures from the "Cross Section View", "Bead Plate Top View" and "Piston Bottom View" columns from the appropriate bellows section that was previously determined. Also, verify that the alignment (bead plate mounting in reference to piston mounting holes) is correct.

In addition, the piston can be further verified by reading the identification numbers inside the piston and comparing these with those shown in the "Piston Bottom View" or piston index. Once a match has been determined, the corresponding assembly order number (i.e. W01-358-9082) can be used to order the part.

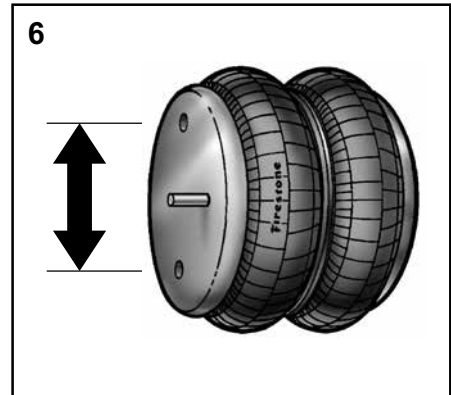

## 6. Convoluted style (bead plates)

The same bellows is used with many different combinations of bead plates. Compare these bead plates with those diagrammed in this guide under the "Bead Plate Top View" and "Bead Plate Bottom View" columns for the specific style convoluted part that was previously determined and find the unit with the identical hardware, measurements and alignment (top bead plate mounting in reference to lower bead plate mounting). Once a match has been determined, the corresponding assembly order number (e.g., W01-358-7135) can be used to order the part.