

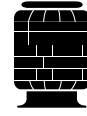

# Firestone

World's Number 1  
Air Spring.



FIRESTONE INDUSTRIAL PRODUCTS COMPANY

**AIRSTROKE™**  
ACTUATORS

**AIRMOUNT™**  
ISOLATORS

## Engineering Manual & Design Guide

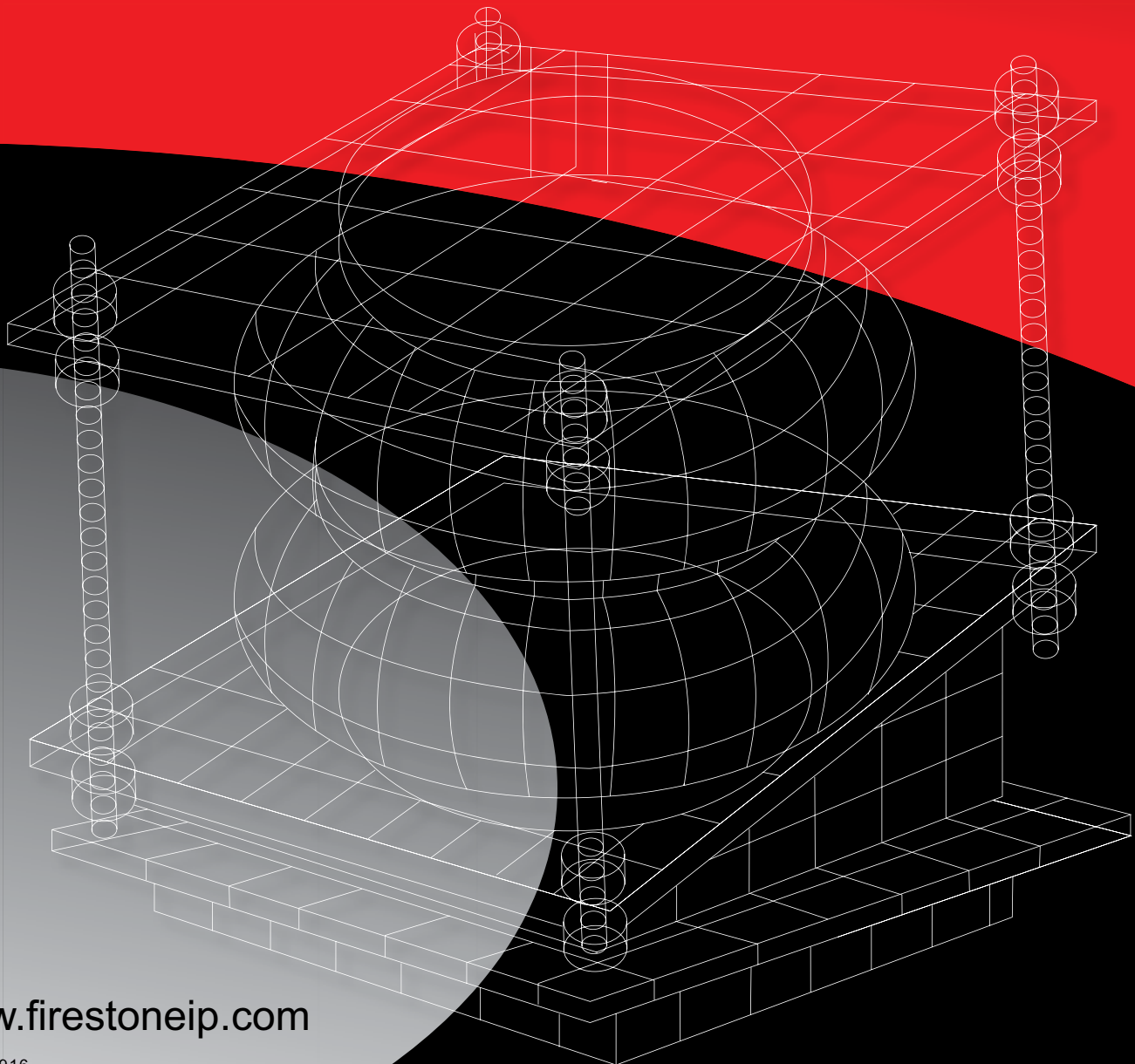

# TABLE OF CONTENTS

Table of Contents and Introduction .....	2	Airmount Vibration Isolation	
Advantages of Airstroke Actuators.....	3	Selection Procedure and Isolation Formula ..	21–22
Advantages of Airmount Isolators .....	4	Dynamic Spring Rate Formula.....	22
Air Spring Bellows Construction.....	5	Natural Frequency Formula .....	22
End Closure Options		Center of Gravity .....	23
Crimped Bead Plates .....	6	Lateral Rates and Stability.....	23
Crimped Bead Plates Mounting Hardware.....	7	Triple Convolute and Reversible	
Steel Bead Rings.....	8	Sleeve Type Parts.....	24
Aluminum Bead Rings.....	9	Design Envelope.....	24
The Three Types of Bead Rings, Mounting		Safety Stops .....	24
Hardware and Plate Machining Requirements....	10	Initial Installation.....	24
Rolled Plates.....	11	Startup and Shutdown/Resonance	
How to use the Static Data Chart		and Amplification.....	24
For Airstroke Actuation .....	12–13	Isolating an Unbalanced Mass .....	24
For Airmount Isolation.....	13	Low Pressure Operation .....	24
Internal Rubber Bumpers .....	13	Effect of an Auxiliary Reservoir .....	24
Basic Parameters Applicable to Both Airstroke		Damping.....	25
Actuators and Airmount Isolators		Plumbing Systems.....	25
Media .....	14	Isolation Chart .....	26
Pressure.....	14	Airmount Isolation Problem Solvers.....	27–28
Temperature .....	14	Miscellaneous Applications	
Contaminants .....	14	Shock Impact Isolation .....	29
Storage.....	14	Protective Boot and Flexible Connector.....	29
Airstroke Actuation		Vacuum Pump .....	29
Selection .....	15	Inflatable Chuck.....	29
Down and Up Stops.....	15	Cam Follower.....	29
Return.....	15	Miscellaneous Problem Solvers .....	30–31
Guiding.....	15	Airstroke/Airmount Selection Guide.....	32–33
Angular Capability .....	15–16	Individual Air Spring Data Pages.....	35–101
Horizontal Misalignment .....	16	Index & Work Sheets	
Design Envelope.....	16	Order Number to Style Number	
Stacking .....	16	to Page Number .....	106–107
Fail-Safe Devices.....	16	Airstroke Design Parameter Worksheet.....	109
Vacuum .....	16	Airmount Design Parameter Worksheet .....	111
Inflation Pressure Chart .....	17	Style Number to Page Number.....	113
Airstroke Actuator Problem Solvers.....	18–20		

## INTRODUCTION

Firestone developed the air spring in the late 1930's as a more efficient spring (vibration isolator) for use in vehicle suspensions. Airide™ springs, as they were named, provided the means for a suspension to reduce the amount of road shock and vibration transmitted into the vehicle. Millions of miles of actual use have proven the dependability and effectiveness of the air suspension concept using Airide™ springs by Firestone.

Airstroke™ actuators, Airmount™ isolators, and Airide™ springs are Firestone registered trademark names for one product: the air spring. The use of the air spring (actuator, industrial isolator and vehicular isolator, respectively) determines which name is applied to it. All of the parts in this catalogue may be used as Airstroke actuators (except the 2M1A) or Airmount isolators, with two exceptions: Triple convolute and reversible sleeve type air springs (except the 1M1A-0) should not be used as Airmount isolators without consulting Firestone.

Individual Airstroke actuators and Airmount isolators are capable of generating a force or supporting a load of up to 100,000 pounds, and a stroke capability of up to 14 inches is possible. Included in this engineering manual are detailed operating characteristics for many of the standard Firestone air springs, along with technical details and procedures for using these products.

### PLEASE NOTE:

The information contained in this publication is intended to provide a general guide to the characteristics and applications of these products. The material, herein, was developed through engineering design and development, testing and actual applications and is believed to be reliable and accurate. Firestone, however, makes no warranty, expressed or implied, of this information. Anyone making use of this material does so at his own risk and assumes all liability resulting from such use. It is suggested that competent professional assistance be employed for specific applications.

# ADVANTAGES OF FIRESTONE AIRSTROKE™ ACTUATORS

*Why use an Airstroke actuator (rather than air or hydraulic cylinder) for actuation?*

## **LOW COST**

Generally, initial cost is one-half or less than conventional pneumatic or hydraulic cylinders of the same force capabilities. This initial cost advantage is many times greater in the larger sizes.

## **WIDE SIZE RANGE**

Airstroke actuators are available in sizes ranging from 2.2 inches to 37 inches in diameter. The force capability is up to 100,000 pounds. Strokes of up to 14 inches are possible.

## **DURABLE FOR LONG LIFE**

Airstroke actuators are a further application of Firestone's time proven Airide springs for truck and bus suspensions. The long life and durability necessary for millions of miles of heavy duty suspension use under adverse environmental conditions are also important factors in machine design.

## **NO MAINTENANCE OR LUBRICATION REQUIRED**

## **NO INTERNAL ROD OR PISTON**

Airstroke actuators have no internal rod, piston, or sliding seals as do conventional cylinders. This allows for the design of Airstroke actuators into applications where dirt or grit would destroy the seals on conventional cylinders.

## **FRICTION FREE FOR IMMEDIATE RESPONSE**

Since Airstroke actuators have no sliding seals, there is no breakaway friction as with conventional cylinders

## **FLEXIBLE MEDIA**

An Airstroke actuator can do its work with either a liquid or gas (Please see page 14 for acceptable media choices.)

## **ANGULAR CAPABILITY**

An Airstroke possesses the unique capability of stroking through an arc without a clevis. Angular motion of up to 30 degrees is possible, along with the design advantage of generally less complex linkages.

## **SIDE LOADING CAPABILITY**

Airstroke actuators, within 20% max off-set load, are not affected by side loads as are conventional cylinders. This misalignment capability eliminates potential rod bending, scoring, and excessive seal wear common to conventional cylinders.

## **COMPACT STARTING HEIGHT**

Airstroke actuators have a low profile compared to conventional cylinders. Our smallest Airstroke actuator (2.2 inch/dia.) collapses to just 1.1 inches in height, while our largest triple convoluted Airstroke (37 inch/dia.) will collapse to a very compact 5.5 inches.

## **FACTORY SEALED AND TESTED**

Most Airstroke actuators feature Firestone's proven concept of crimped end plates. The crimped design allows for preshipment testing and quicker installation on equipment.

PLEASE REFER TO PAGE 15 FOR A THOROUGH DISCUSSION OF ACTUATION.

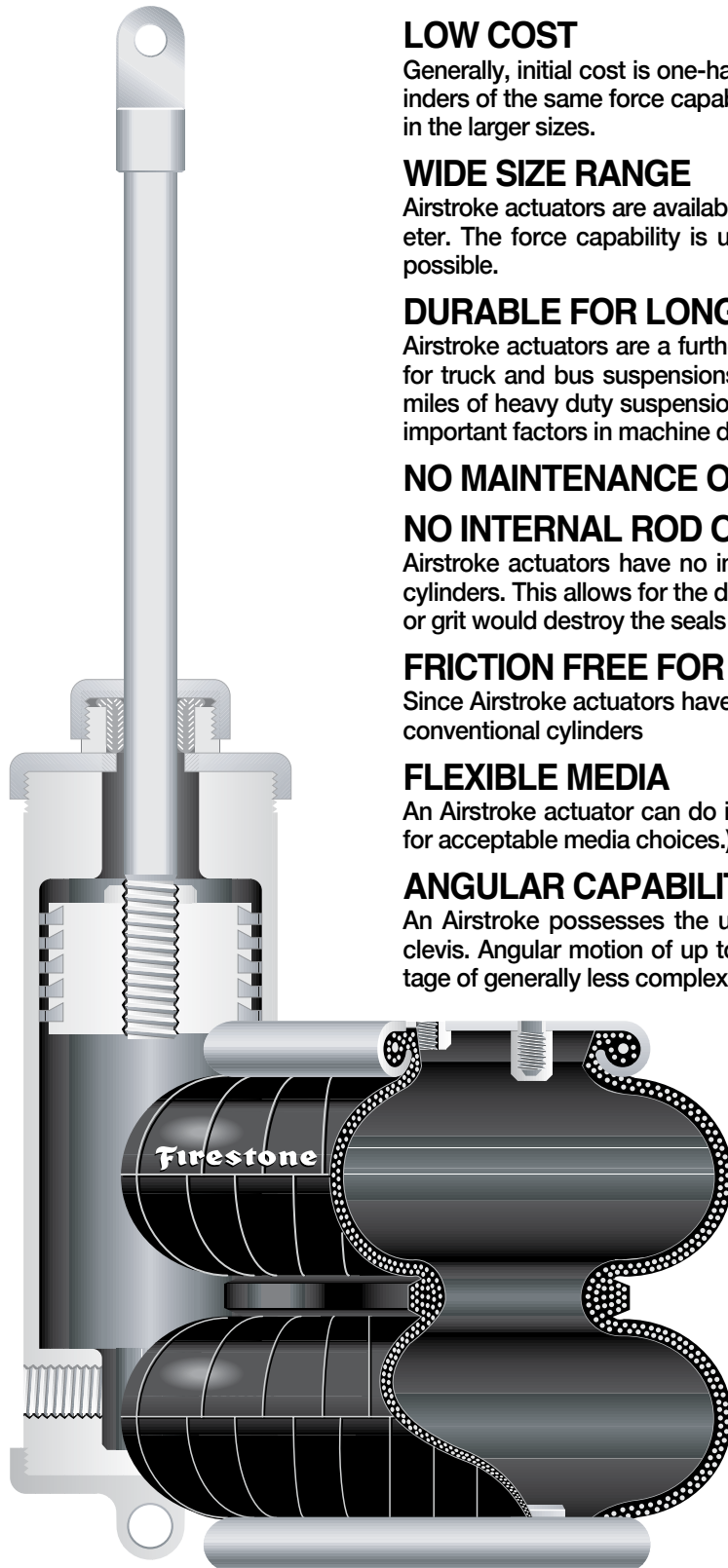

# ADVANTAGES OF FIRESTONE AIRMOUNT™ ISOLATORS

*Why use an Airmount isolator rather than a coil spring or other type of isolator?*

## UNSURPASSED ISOLATION CAPABILITY

Airmount isolators can provide the highest degree of isolation of any type vibration isolator. System natural frequencies as low as 60 cycles per minute (1 Hertz) are available. The addition of an auxiliary reservoir can provide even lower system frequencies. In order to achieve similar results from a conventional coil spring isolator, a real deflection of 9 inches would be required.

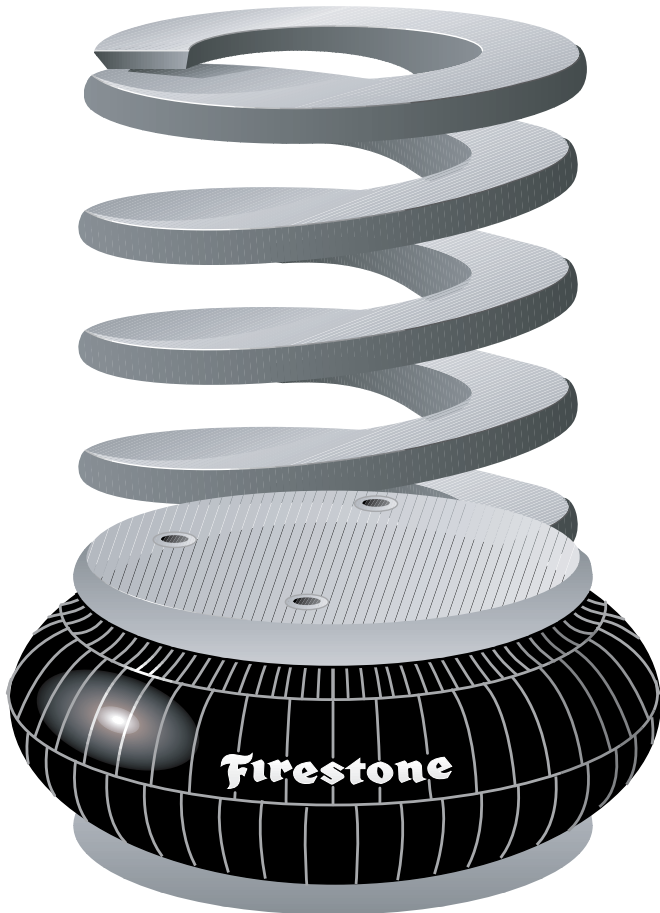

## CONSTANT ISOLATION EFFICIENCY

Airmount isolators are unique in that the system's natural frequency does not change significantly with changes in load. This unique feature, combined with accurate height control, will allow the use of the same Airmount isolator at each mounting point of an unevenly loaded machine.

## ACCURATE HEIGHT CONTROL

Airmount isolators provide accurate height control through regulation of internal air pressure. This feature eliminates the fatigue and permanent set found in the use of other types of vibration isolators.

## WIDE SIZE RANGE

Airmount isolators are capable of isolating loads of 100 pounds per mounting point to over 100,000 pounds per mounting point.

## COMPACT INSTALLED HEIGHT

Airmount isolators can carry the loads and provide the isolation described above at installed heights as low as 2.5 inches. Coil springs providing equal isolation would require a free height of 5 to 25 inches.

## EXTENDED EQUIPMENT LIFE

Airmount isolators extend equipment life through their superior isolation capabilities.

## EFFECTIVE NOISE REDUCTION

Airmount isolators reduce structurally transmitted noise. Airmount isolators are also quiet in themselves, since there is no spring chatter as found in conventional coil springs.

## VERSATILE

Airmount isolators can be used not only to protect structural members from vibrating machinery, but are also widely used to protect delicate equipment from structurally transmitted vibration.

PLEASE REFER TO PAGE 21 FOR A THOROUGH DISCUSSION OF VIBRATION ISOLATION.

# AIR SPRING BELLOWS CONSTRUCTION

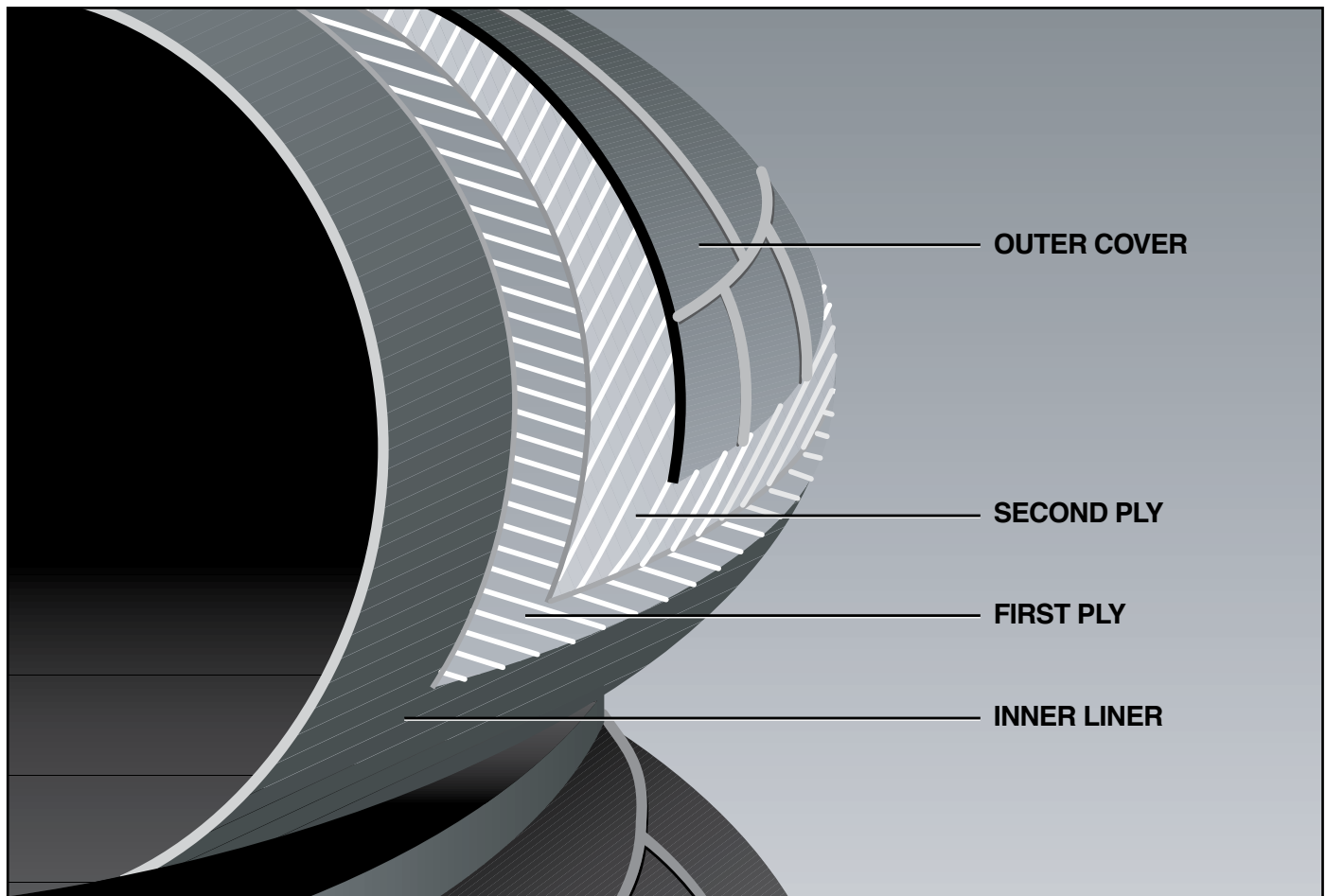

An air spring is a carefully designed rubber/fabric bellows which contains a column of compressed air. The rubber bellows itself does not provide force or support load. This is done by the column of air.

Firestone air springs are highly engineered elastomeric bellows with specially designed metal end closures. Our standard two ply air spring bellows is actually made up of four layers:

- An inner liner of calendered rubber.
- One ply of fabric reinforced rubber.
- A second ply of fabric-reinforced rubber (with the cords at a specific bias angle to the first ply).
- An outer cover of calendered rubber.

Many of our air springs are also available in high strength construction for higher pressures (see page 14 for more detailed information). In this case, there are two plies (in the standard construction) of fabric-reinforced rubber, with an inner liner and outer cover.

The two ply air spring is standard. Where high strength construction is available, it is so noted in the selection guide (page 32), on the individual Data sheets, and in the index (page 106). If the high strength style number is omitted, then it is not currently available in that particular part.

Each air spring bellows is identified by a style number. This style number is molded into the bellows during the curing (or vulcanization) process. Examples would be 16, 22, 313, 1T15M-6, etc... This identifies *only* the rubber/fabric bellows and *not the complete assembly*. There are several different end closure options available for most air springs; therefore, please always specify both the style number and the complete **assembly order number (AON)**. An example would be: Style #22, assembly order number W01-358-7180. Both numbers are given on the individual data sheets.

# END CLOSURE OPTIONS

Each individual air spring data sheet shows a cross sectional view of the most popular end closure option for that part. For convoluted air springs 16 inches in diameter and less, and for the reversible sleeve air springs, *the Crimped*

*Bead Plate attachment is shown. For convoluted air springs 17 inches in diameter and larger, a Bead Ring attachment is shown. An air spring of each variety, with proper terminology for each, is shown on the following pages.*

## CRIMPED BEAD PLATES

### CONVOLUTED AIR SPRINGS

(#22 is shown)

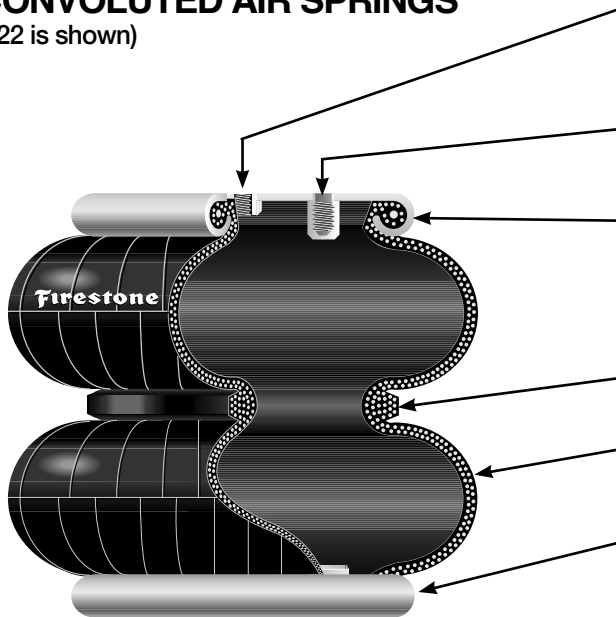

#### AIR INLET

1/4" NPT is standard. 3/4" NPT is also available for most parts. (See the data sheet order block on each specific part).

#### BLIND NUT

3/8-16 UNC thread x 5/8" deep (two or four per each plate depending on part size). Used for mounting the part.

#### UPPER BEAD PLATE

(9 gauge carbon steel, .149"). Permanently crimped to bellows to form an airtight assembly which allows for leak testing before the unit leaves the factory. Zinc/chromate plated for rust protection.

#### GIRDLE HOOP

Wire wound type shown, molded into the bellows.

#### BELLOWS

Wall gauge is approximately 1/4". See page 5 for detailed information.

#### LOWER BEAD PLATE

Usually the same as upper bead plate, except without air inlet.

### REVERSIBLE SLEEVE AIR SPRINGS

(1T15M-6 is shown)

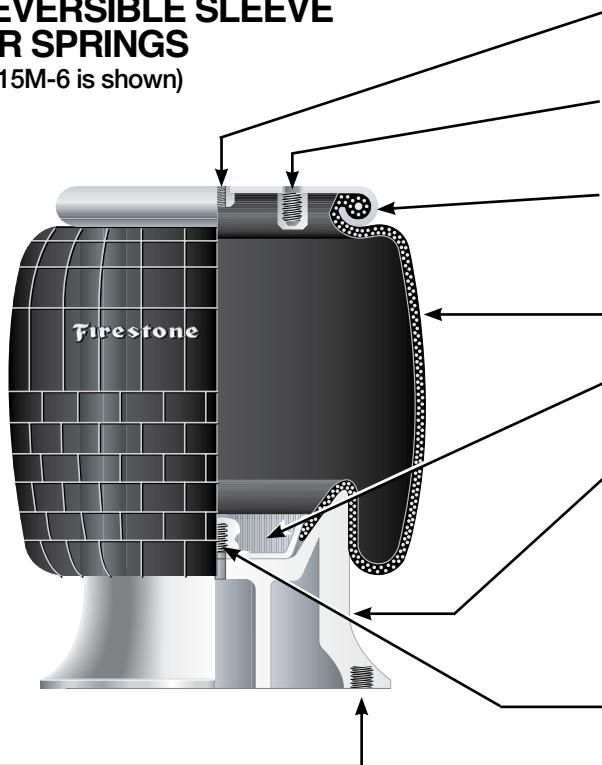

**AIR INLET** 1/4" NPT is standard. 3/4" NPT is also available for most parts. (See the data sheet order block on each specific part).

**BLIND NUT** 3/8-16 UNC thread x 5/8" deep (two or four per each plate depending on part size). Used for mounting the part.

**BEAD PLATE** (9 gauge carbon steel, .149"). Permanently crimped to bellows to form an airtight assembly which allows for leak testing before the unit leaves the factory. Zinc/chromate plated for rust protection.

**BELLOWS** Wall gauge is approximately 1/4". See page 5 for detailed information.

**BELLOWS END CLOSURE**—(steel) Permanently molded into the bellows (Except for styles 1T19L-7, 1T19L-11).

**PISTON** May be made of aluminum, steel, plastic or hard rubber. Held to the bellows by a bolt which screws into the bumper stud. For mounting, a long bolt may be used coming up through the mounting surface. Or, a short bolt may be used to attach the piston to the lower end closure and then use the threaded holes in the piston to secure the assembly to the mounting surface. (A piston long bolt is usually not included).

**BUMPER STUD** A permanent part of the bellows end closure (and bellows). It has two functions:

1. The optional rubber bumper snaps over the outside.
2. The inside is a threaded hole (see data sheets for thread dimension and depth) used to secure the piston to the bellows.

**THREADED HOLE** May be used for attachment to mounting surface. Not included in some pistons (See individual data sheets for specific part configuration.)

# CRIMPED BEAD PLATE MOUNTING HARDWARE

**CRIMPED BEAD PLATE AIR SPRINGS** Use the blind nuts for attachment. This is accomplished by bringing bolts (two or four depending upon air spring size)

through the customer supplied mounting plate and tightening into the blind nut. If this bolt is too long, it may fracture the bottom out of the blind nut.

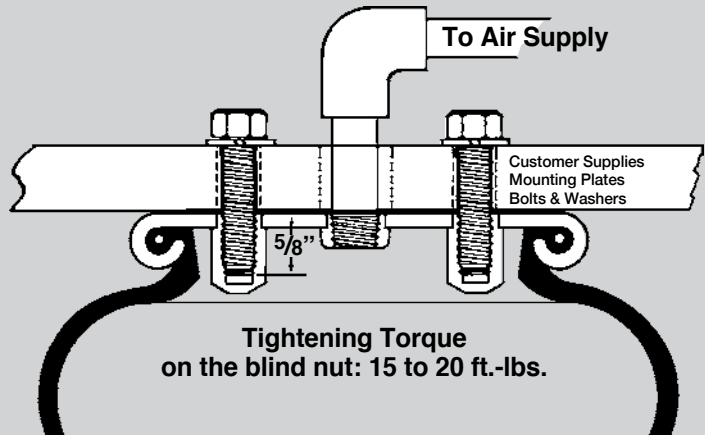
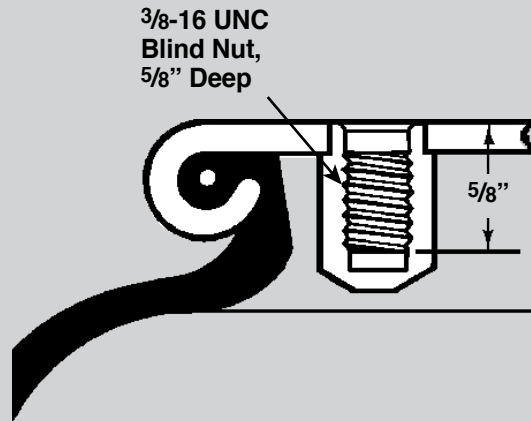

## STUD ADAPTER

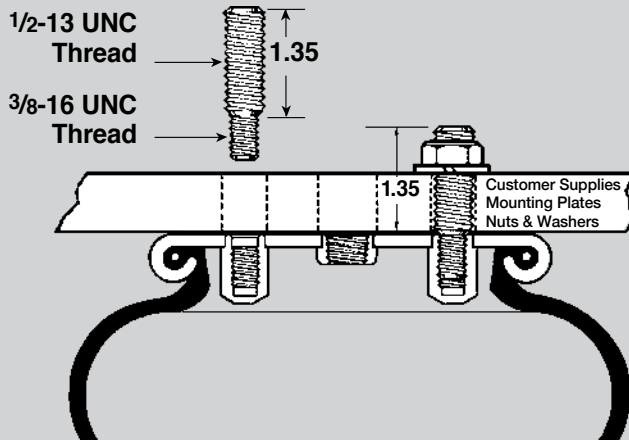

If a protruding bolt rather than a blind nut is preferred to attach the air spring, a STUD ADAPTER is available from Firestone:

Description	Order No.
Imperial Stud Adapter	WC1-358-0361

**TANK VALVE** One method for inflating air springs (primarily used in Airmount isolator applications) is with a tank valve: An air hose chuck is used (as inflating a tire with an air line). Care must be taken to periodically check the pressure within the air

spring, because air will slowly permeate through the rubber/fabric bellows (See page 25).

Description	Order No.
Tank Valve	WC1-358-0009

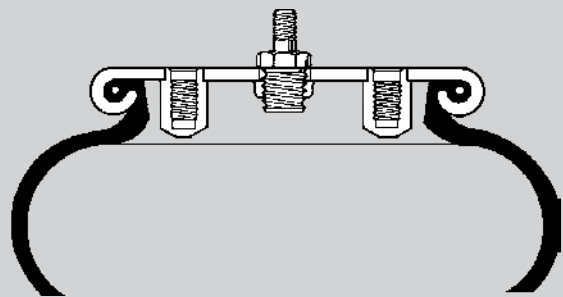
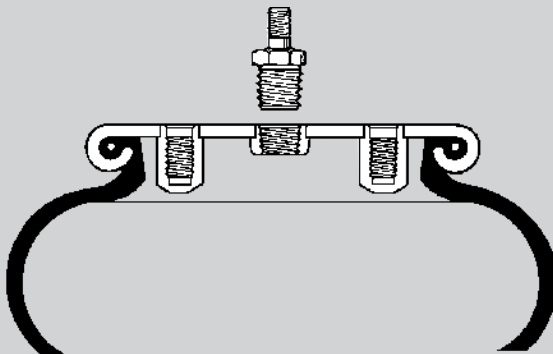

# END CLOSURE OPTIONS

## STEEL BEAD RINGS

### CONVOLUTED AIR SPRINGS

(#22 is shown, with bead rings instead of crimped bead plates)

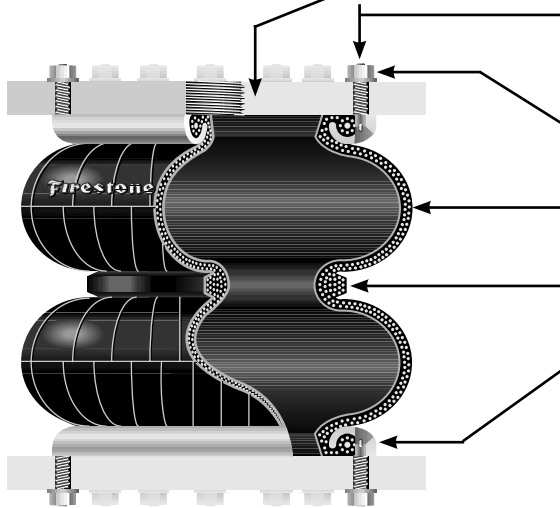

**MOUNTING PLATE** *is not included.* See page 10 for material, machining recommendations, and installation instructions.

**BEAD RING BOLT** May be one of three varieties. See page 10. Also refer to the data sheet order block on each individual part for bolt lengths.

**NUTS AND LOCKWASHERS** *are included* with the part. (Except for socket head type bead rings).

**BELLOWS** Wall gauge is approximately 1/4". See page 5 for detailed information.

**GIRDLE HOOP** Wire wound type shown, molded into the bellows.

**BEAD RING**, upper and lower. Countersunk steel type shown. See page 10. Also refer to the data sheet order block on each part for type and material. See the selection guide on page 32 for bolt circle diameter and number of bolts (each ring).

### REVERSIBLE SLEEVE AIR SPRINGS

(1T15M-6 is shown, with a bead ring instead of a crimped bead plate)

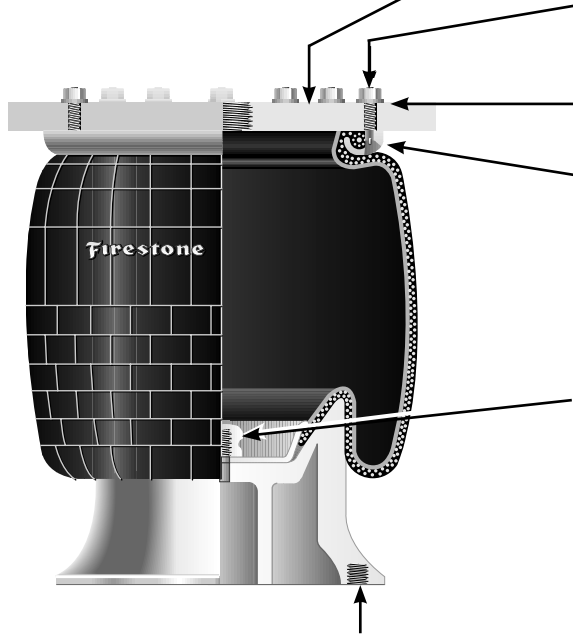

**MOUNTING PLATE** *is not included.* See page 10 for material, machining recommendations, and installation instructions.

**BEAD RING BOLT** May be one of three varieties. See below. Also refer to the data sheet order block on each individual part for bolt lengths.

**NUTS AND LOCKWASHERS** *are included* with the part. (Except for socket head type bead rings).

**BEAD RING** Countersunk steel type shown. See the selection guide on page 32 for bolt circle diameter and number of bolts (each ring).

**BUMPER STUD** A permanent part of the bellows end closure (and bellows). It has two functions:

1. The optional rubber bumper snaps over the outside (of it).
2. The inside is a threaded hole (see data sheets for thread dimension and depth) used to secure the piston to the bellows.

**THREADED HOLE** May be used for attachment to mounting surface. Not included in some pistons (See individual data sheets for specific part configuration.)



# END CLOSURE OPTIONS

## LARGE PARTS WITH ALUMINUM BEAD RINGS

All of the parts that are shown with crimped bead plates are also available with bead rings. (Bead plates are not suitable for some applications.) Typical examples of where bead rings are often used follow:

1. Where parts are stacked to increase stroke (See page 16).
2. Where the air spring is being used as a boot or flexible connector (See page 29).
3. When used as an Airmount isolator with an auxiliary reservoir (See page 24).
4. When air must move in or out of the unit at an extremely fast rate (and a 3/4" NPT air inlet is too small).
5. When used with an internal shaft, to either guide the part or to pull (rather than push) a load.

## CONVOLUTED AIR SPRINGS

(#203 is shown)

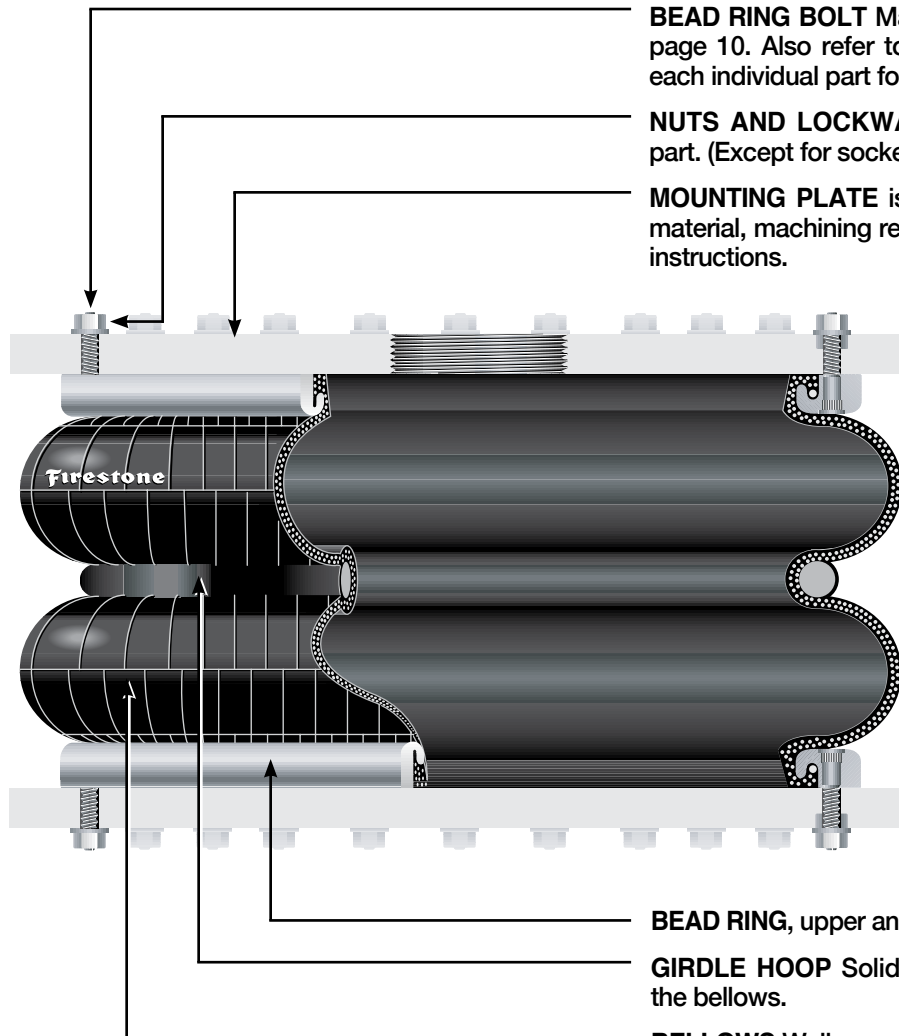

**BEAD RING BOLT** May be one of three varieties. See page 10. Also refer to the data sheet order block on each individual part for bolt lengths.

**NUTS AND LOCKWASHERS** are included with the part. (Except for socket head type bead rings).

**MOUNTING PLATE** is not included. See page 10 for material, machining recommendations, and installation instructions.

**BEAD RING**, upper and lower. (Aluminum)

**GIRDLE HOOP** Solid steel type shown, molded into the bellows.

**BELLOWS** Wall gauge is approximately 1/4". See page 5 for detailed information.

*For more Information Ask your Firestone Rep for Technigram 103.*

# END CLOSURE OPTIONS

## THE THREE TYPES OF BEAD RINGS

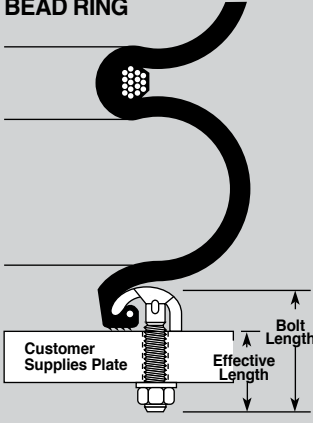
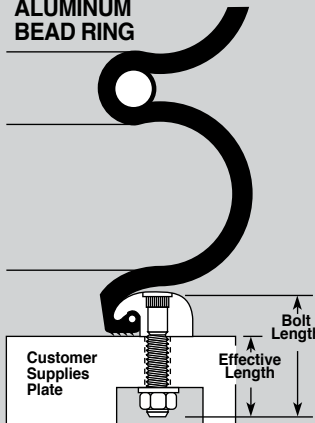
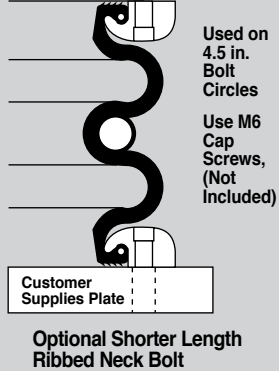
COUNTERSUNK STEEL BEAD RING	RIBBED NECK ALUMINUM BEAD RING	SOCKET HEAD ALUMINUM BEAD RING*
		
<b>Standard Bolt Length (in.)</b> 1 3/4	<b>Standard Bolt Length (in.)</b> 1 7/8	
<b>Standard Effective Length (in.)</b> 1.22	<b>Standard Effective Length (in.)</b> 1.28	
<b>Standard Order Number (bolt only)</b> WC1-358-3625	<b>Standard Order Number (bolt only)</b> WC1-358-3620	
<b>Thread</b> 5/16-24 UNF	<b>Thread</b> 3/8-24 UNF	
<b>Tightening Torque (ft.-lbs.)</b> 17 to 22	<b>Tightening Torque (ft.-lbs.)</b> 28 to 32	

More bolt sizes available. Ask your Firestone Rep for availability.

## BEAD RINGS CONTINUED

### PLATE MACHINING REQUIREMENTS

When using bead rings, THE CUSTOMER WILL NEED TO FABRICATE HIS OWN MOUNTING PLATES. Hot or cold rolled steel provides satisfactory mounting surfaces, with specific finishes of 250 microns, if machined in a circular fashion, and 32 microns when ground. The thickness of mounting plates depends upon the application. The plates must be strong enough and backed by structural members to prevent bowing (of the plates) when subjected to the forces or loads involved. The rubber bellows provides its own seal; therefore, 'O' rings or other sealants are not needed when installing the part.

### INSTALLATION

Follow this technique for assembling a bead ring style bellows to the mounting plate:

- Insert the bolts into the bead ring (the bead rings have been previously attached to the bellows at the factory). The bolts will be pulled into place by the action of tightening the nuts.
- Slip all of the bolts (which are protruding through the bead ring) into the mating holes of the mounting plate and attach the lockwashers and nuts. FINGER TIGHTEN all nuts to produce a uniform gap between the bead ring and mounting plate all the way around.

- At this point, make certain that the bellows bead is properly seated under the bead ring.

PLEASE NOTE THAT UNIFORM SUCCESSIVE TIGHTENING OF THE NUTS IS IMPORTANT TO SEAT THE RUBBER BEAD PROPERLY TO THE MOUNTING PLATE FOR ITS FULL CIRCUMFERENCE.

Continue with the following sequence:

- Tighten all nuts one turn each, moving around the circle until continuous contact is made between the bead ring and mounting plate.
- Torque all nuts to the torque specifications shown on the page, going at least two complete turns around the bolt circle.

### MATERIAL

Bead rings are supplied in either steel or aluminum. Both the bead ring material and type of ring are called out in the description section of the order block on each individual data page. Also, the bolt length (for the bolts supplied with that particular order number) is given.

WHERE A BEAD PLATE PART IS SHOWN AND THE BEAD RING ATTACHMENT IS PREFERRED, PLEASE REFER TO THE SELECTION GUIDE ON PAGE 32 FOR BOLT CIRCLE DIAMETERS AND NUMBER OF BOLTS (EACH RING).

# END CLOSURE OPTIONS

## LARGE PARTS WITH ROLLED PLATES

### LARGE CONVOLUTED AIR SPRINGS

(#203 is shown, with rolled plates instead of bead rings)

The convoluted parts, with 17, 20, and 22 inch diameter, are shown with bead rings as standard. We have developed a method for permanently attaching plates to these larger sized Airstrokes (called rolled plate assembly). These parts may be an advantage over the bead ring parts in some cases, because installation is much easier (they attach the same way as the bead plate parts). When installing the rolled plate parts, a backup plate as large in diameter as the bead plate must be used. This plate should be a minimum of 1/2

inch thick.

Again, for the blind nut and air entrance locations of rolled plate parts (bead rings are shown as standard on the data pages), please refer to the selection guide on page 32. The static data chart on each individual part may be used for the rolled plate version; but, two modifications must be made:

1. Increase the minimum height by .70 inch.
2. Add .70 inch to the height (bottom axis) before reading loads.

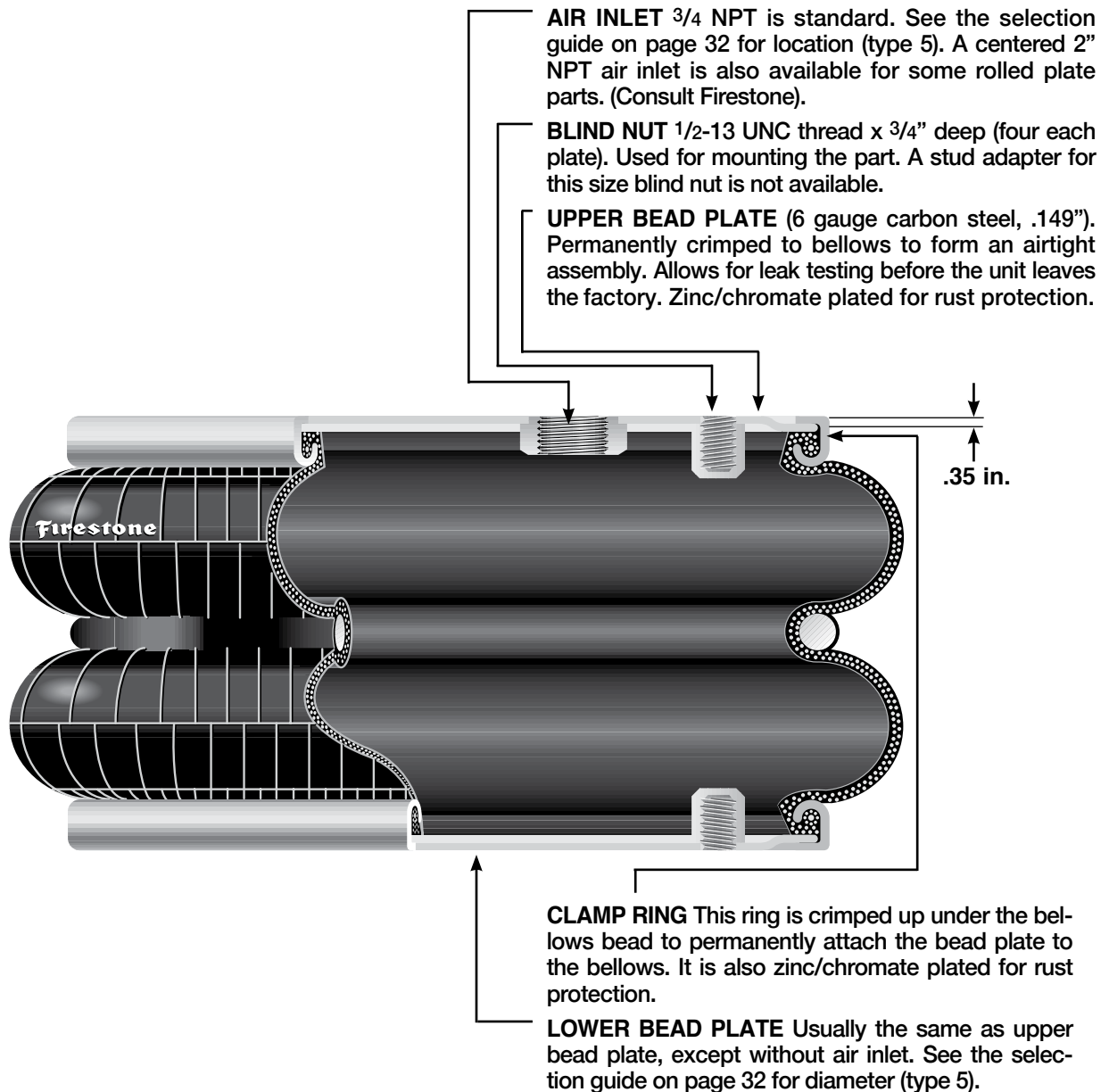

# HOW TO USE THE STATIC DATA CHART

We also refer to this chart as the load/deflection (L/D) curve for an air spring. The force [1] is given on the right hand axis vs. the air spring height [2] as shown along the bottom axis; thus, load vs. deflection. The internal volume [3] is also given along the left hand axis, again vs. height [2]. It is called static data because the air spring is in a static, or non-moving, constant pressure condition. In almost all cases the static curves were run using a two ply bellows; however, *where a four ply bellows is available, use the two ply chart for it also.*

## AIRSTROKE ACTUATION

The important considerations are minimum height [4] (3.0 inches) and maximum recommended height [5] (10.1 inches). Subtracting one from the other gives the stroke potential for this part (10.1 - 3.0 = 7.1 inches). As an actuator, the entire stroke may be used, or any portion thereof. Ignore recommended airmount design height [6] and the corresponding darkened line [7]. This height is important in using the air spring as an isolator (AIRMOUNT). It has nothing to do with the concern here of actuation. To determine the force at any given height, simply move up the height line to where it intersects any of the static pressure curves. Then move to the right and read from the force scale [1].

**EXAMPLE:** At 80 psig, what is the force using a #22 from 4.0 to 9.0 inches, or 9.0 - 4.0 = 5.0 inch stroke? See [8] for force at 4.0 inches (7,180 #) and [9] for force at 9.0 inches (4,670 #). This example illustrates the primary difference between Firestone Airstrokes and conventional air cylinders. Air cylinders have a constant area for the pressure to work against, or constant effective area. *the effective area and force of an air spring changes as the height changes. (There is one exception: notice the plateau section of reversible sleeve 1T type curves.)*

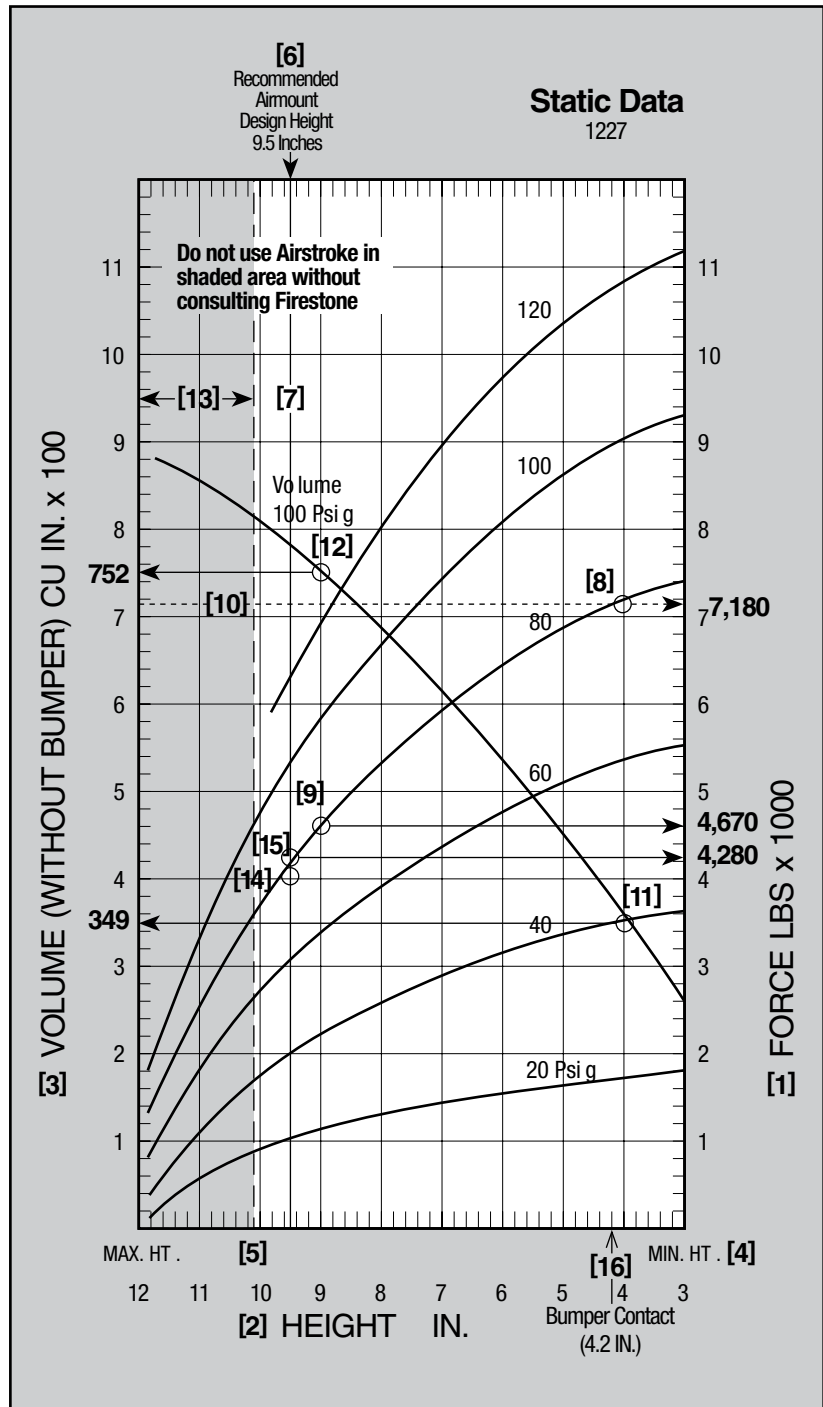

In the example the effective area of a #22, at 4.0 inches using the 80 psi curve, is:

$$\frac{7,180 \text{ lbs.}}{80 \text{ lbs/in}^2} = 89.8 \text{ in}^2$$

at 9.0 inches in height it is:

$$\frac{4,670 \text{ lbs.}}{80 \text{ lbs/in}^2} = 58.4 \text{ in}^2$$

An air cylinder with 89.8 in<sup>2</sup> of area would have an 80 psi curve as shown by dotted line [10].

The volume curve [3] may also be of importance:

- a. If one needs to know the amount of free air (then compressed by the compressor) to perform a desired operation.
- b. If the actuation must be completed quickly and calculations of flow through the air inlet (orifice) are required.

In each case above, the change in internal volume is required. Read up from the two heights involved to the intersecting point with the volume curve. Then move to the left and read from the volume scale. In the example at 4.0 a #22 (notice most volume curves are at 100 psig) has an internal volume of 349 in<sup>3</sup> [11] and at 9.0 the volume is 752 in<sup>3</sup> [12]. The change in volume is then 752 in<sup>3</sup> – 349 in<sup>3</sup>, or 403 in<sup>3</sup>. The volume at minimum height (349 in<sup>3</sup>) would not be subtracted if exhausting the air spring to atmospheric pressure.

Notice the shaded area [13]. We do not recommend that an air spring be used at heights extending into this section. The “beginning of the shaded area” for a #22 is at 101 inches [5].

SEE PAGE 15 FOR A MORE DETAILED DISCUSSION OF ACTUATION.

## AIRMOUNT ISOLATION

Because of lateral stability considerations (see page 23 for more details) we recommend that each air spring be used at a *specific height* when used as an *isolator*. This specific height is called the “Airmount design height” [6]. The vertical line running through this height [7] is darkened so that it is easy to see where it intersects the static curves for load readings.

EXAMPLE: Support a 4,100 pound load with an air spring. Would a #22 be appropriate, and if so, at what height? The height isn’t much of a problem, as this part **SHOULD BE USED AT 9.5 INCHES**. Simply move up the darkened line to where it intersects 4,100 lbs [14]. That point falls between the 80 and 60 psig curves. Exactly what pressure would be required? Use the formula:

$$\text{Effective Area} = \frac{\text{Load (lbs.)}}{\text{Pressure (lbs/in}^2\text{)}}$$

Determine the effective area at 9.5 inches (using the 80 psig curve, since 80 psig would be closer to our exact pressure than 60 psig), or:

$$\text{Effective Area} = \frac{4,280 \text{ lbs. [15]}}{80 \text{ lbs/in}^2} = 53.5 \text{ in}^2$$

Then divide the actual load by the effective area:

$$\frac{4,100 \text{ lbs.}}{53.5 \text{ in}^2} = 76.6 \text{ PSIG}$$

The pressure required to support 4,100 lbs. with a #22 at a design height of 9.5 inches is therefore 76.6 PSIG.

Please note that the static data can be converted to dynamic data (the air spring is in motion) by applying the formulas that are presented in the Airmount isolation section on page 22.

SEE PAGE 21 FOR A MORE DETAILED DISCUSSION OF VIBRATION ISOLATION.

## INTERNAL RUBBER BUMPERS

Some parts are available with internal rubber bumpers. Where a bumper is available, it is shown as a dotted line in the cross sectional view of the air spring. Additionally, please note that:

1. the minimum height is increased to the “bumper contact” point [16] (this reduces the total available stroke somewhat, by 4.2 – 3.0 = 1.2 inches in our #22 example), and
2. the order block contains the proper ordering numbers for parts with bumpers.

# BASIC PARAMETERS APPLICABLE TO BOTH AIRSTROKE™ ACTUATORS AND AIRMOUNT™ ISOLATORS

## MEDIA

Air springs are designed for use with compressed air. Nitrogen is also acceptable. Air springs may be filled with water or water-glycol (automotive antifreeze) solutions. If water is to be used, rust inhibitors should be added to protect the end closures. Two reasons for liquid filling an air spring are:

1. To reduce the internal volume of air (and therefore, *increase* the natural frequency of the air spring) and,
2. To use a media which is incompressible. Accurate positioning would be one reason to do this.

Petroleum base fluids (most hydraulic oils fall into this category) are **NOT RECOMMENDED**. Moderately lubricated air will not harm the bellows.

## PRESSURE

1. 100 PSIG MAXIMUM FOR 2 PLY.
2. 175 PSIG MAXIMUM FOR HIGH STRENGTH.

We recommend that there be a minimum three times safety factor between maximum internal air pressure and burst pressure. So, as an example, if 100 psig is required, the burst should be at 300 psig or greater. For convoluted air springs, the burst pressure decreases as height increases. Therefore, the determining factors are twofold: What is the maximum height into extension and what is the internal pressure at that point? Please see the Airstroke Inflation Pressure Chart (for single, double, and triple convoluted air springs) on page 17 for specific pressure vs. height information.

For AIRMOUNT applications (where the part is used at a height very close to the shaded area), it is best to stay within 100 psig maximum for a two ply, and 150 psig maximum for a four ply or high strength cord air spring.

## STORAGE

The best storage environment is a dark, dry area at normal room temperature.

## TEMPERATURE

1. **STANDARD ALL NATURAL RUBBER BELLOWS (LOW TEMPERATURE COMPOUND)**. Our standard industrial air springs should be limited to use in the range:

**- 65° F to +135° F**

2. **EPICHLOROHYDRIN (HIGH TEMPERATURE COMPOUND)**. Most convoluted parts are available in this material. The operating temperature range for it is:

**0° F to 225° F**

Additionally, Epichlorohydrin has very good oil resistance. **ALL EPICHLOROHYDRIN APPLICATIONS MUST BE APPROVED BY FIRESTONE**. For more information on Epichlorohydrin (also known as Herclor), ask for Technigram number 111.

3. **NEOPRENE (HIGH TEMPERATURE COMPOUND)**. Neoprene is more resistant to damage from oil. For this reason, Firestone Neoprene has been used as the inside layer in two configurations to reduce the hazard of having oil in the pneumatic plumbing system. The third configuration includes an outer layer of Firestone Neoprene for applications that expose the exterior of the air spring to an oil environment. In addition, Firestone Neoprene is able to withstand higher temperatures than natural rubber:

**-35° F to +165° F**

4. **POLYACTUATOR PRODUCT LINE**. Standard construction has a temperature rating of:

**-22° F to +140° F**

## CONTAMINATES

Shielding should be used to protect the bellows from exposure to hot metal, sand, petroleum base fluids, acids, etc. Please consult Firestone if you wish to know how the bellows will withstand a specific contaminant (For liquids such as acids, it is important to know both concentration and temperature).

## WARNING

**DO NOT INFLATE ASSEMBLY WHEN IT IS UNRESTRICTED. ASSEMBLY MUST BE RESTRICTED BY SUSPENSION OR OTHER ADEQUATE STRUCTURE. DO NOT INFLATE BEYOND PRESSURES RECOMMENDED IN DESIGN LITERATURE (CONTACT FIRESTONE FOR INFORMATION). IMPROPER USE OR OVERINFLATION MAY CAUSE ASSEMBLY TO BURST CAUSING PROPERTY DAMAGE OR SEVERE PERSONAL INJURY.**

# AIRSTROKE ACTUATION

## SELECTION

1. Refer to the selection guide on page 32 for Airstroke force and stroke capabilities. After your list of possibilities has been reduced to one or two air springs, then turn to the individual data page for more detailed information on those parts.
2. **STROKE:** The maximum STROKE CAPABILITY is the difference between the height corresponding to the “start of the shaded area” minus the minimum height. This entire stroke, or any portion thereof, may be used. If an internal rubber bumper is required, please note that the minimum height is increased, and therefore, the total stroke is decreased.
3. **FORCE:** Read the forces directly from the static data chart, or, use the force table located under the chart. Notice that the force generally decreases as height increases. This feature is discussed in detail on page 12 in the section entitled “How to Use the Static Data Chart.”
4. **SELECT THE END CLOSURES AND AIR INLET SIZE:** Most Airstroke actuators are available with permanently attached plates or bead ring attachments. If an alternate end closure option is available, it is so stated under the cross sectional view of the part. Please refer to page 6 for a detailed discussion of end closure options.

## DOWN AND UP STOPS

Positive stops in both directions (compression and extension) should always be used with Airstroke actuators .

1. In **COMPRESSION**, the minimum height shown for each air spring is at, or slightly above the **PINCH POINT** of the bellows. Here is a #22 shown in the collapsed or “pinch point” condition:

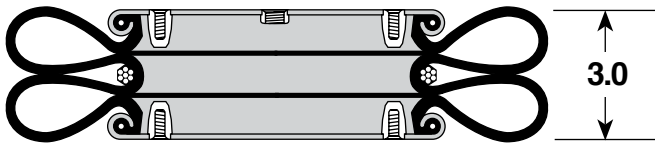

The bellows can be damaged if allowed to constantly bottom out as shown above; therefore, a downstop is required to prevent this. An external downstop can be something as simple as a steel block and should be sized at or slightly greater than the minimum height of the Airstroke. In our #22 example, the block would need to be at least 3.0 inches high. If an external downstop cannot be used, many parts are available with internal rubber bumpers (shown as a dotted line in the cross-sectional view of the air spring where available).

2. In **EXTENSION**, an upstop is required to prevent the air spring from overextending at heights into the shaded area of the graph. The reasons for this are twofold: a) the life of the bellows may be reduced and b) the crimp may open up, allowing the bellows bead to blow out of the metal end closure. There are many ways to design-in an upstop, including
  - a. a chain,
  - b. a cable,
  - c. contacting a metal stop, etc.

## RETURN

An Airstroke actuator is a *single acting* device. To return the Airstroke to its minimum height (for another cycle or stroke), some return force must be used. Gravity acting on the load may be all that's required. The force to collapse the convoluted type Airstrokes to minimum height is given in the order block section for each part. If the load is not sufficient, then a second Airstroke or coil spring may be required.

## GUIDING

*An Airstroke follows the path of least resistance;* therefore, the actuator should be guided in most instances. This is often easily accomplished in the mounting geometry.

## ANGULAR CAPABILITY

An Airstroke actuator can stroke through an arc (without a clevis). Angular motion of up to 30 degrees is possible. When using an actuator with the mounting plates at an angle to each other, observe the following:

- a. Measure force at the height between the plate centers.
- b. Measure maximum height at the side separated the furthest.
- c. Measure minimum height at the side collapsed the most.
- d. Limit the horizontal misalignment between the two plates. We recommend one inch misalignment for each convolution.

### Angular Capability continued

These measurements must fall within the guide lines for that particular part. Consider style #22 in the following scissors arrangement:

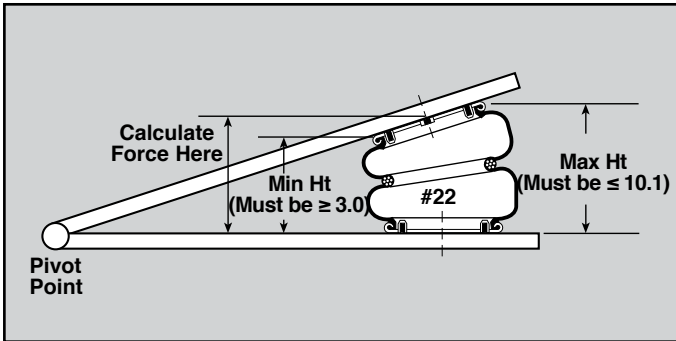

Reversible sleeve Type 1T parts may also stroke through an arc. In this case, care must be taken to prevent the bellows from rubbing (internally) against itself where it rolls over the piston:

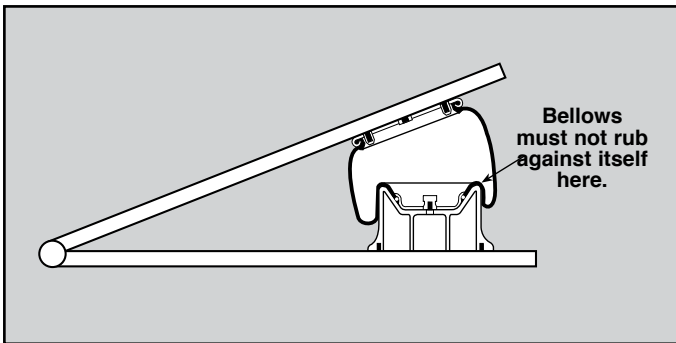

**NOTE:** The max and min height are not the vertical distance but the actual distance the bellows moves with the angle.

### HORIZONTAL MISALIGNMENT

The upper and lower bead plate centers (or mounting plate centers in the case of a bead ring type attachment) may be out of line somewhat without injury to the bellows. Our “rule of thumb” for convoluted type Airstrokes is one inch misalignment allowed per convolution. So, a single convoluted air spring may be out of line by as much as 1 inch, a double by 2 inches, and a triple convoluted air spring by 3 inches.

### DESIGN ENVELOPE

Adequate clearance should be provided around the Airstroke to prevent puncturing or rubbing of the bellows. The maximum diameter @ 100 psig for each Airstroke (bellows) is located just above the cross-sectional view of the air spring.

### STACKING

It is permissible to stack Airstrokes (one on top of another) to increase stroke; however, the center plate (or plates) connecting the two or more Airstrokes **MUST BE GUIDED**.

Please note that the air spring forces are *not* additive in this configuration. A method for guiding, which also illustrates one center ring concept for mounting the two parts together at the middle, is illustrated below:

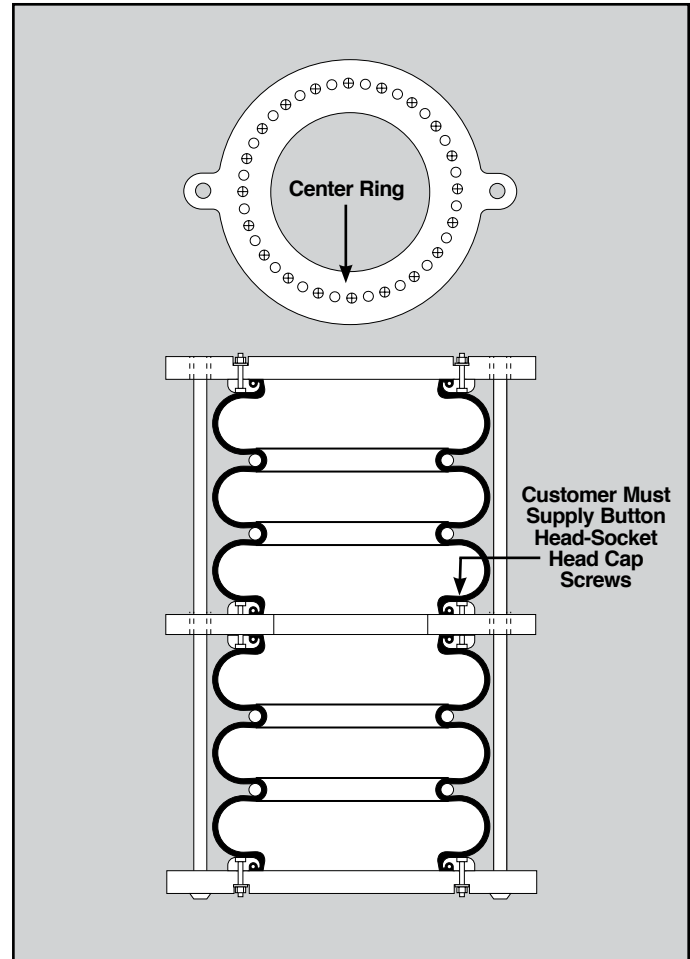

### FAIL SAFE DEVICES

Some applications require the use of fail safe mechanisms (such as a mechanical lock-out on a scissors lift) to prevent damage or injury in the event of an air system failure.

### VACUUM

An Airstroke can withstand a small amount of vacuum without injury to the bellows. The maximum amount of acceptable vacuum is dependent upon the bellows' size, the height in use, and whether it is a two ply or high strength (fabric) air spring. (A high strength Airstroke bellows has a “stiffer” wall than a two ply; therefore, it is less susceptible to dimpling and deformation inward). **BEFORE USING THE AIRSTROKE WITH A VACUUM, PLEASE CONSULT YOUR FIRESTONE REPRESENTATIVE.**

**An Airstroke Design Parameter Worksheet can be found on page 109.**



# AIRSTROKE

## INFLATION PRESSURE CHART

MAXIMUM RECOMMENDED INTERNAL PRESSURES FOR CONVOLUTED TYPE AIRSTROKE™ ACTUATOR APPLICATIONS

BASED ON APPROXIMATELY 1/3 NORMAL BURST VALUES  
APPLICATIONS WHICH EXCEED THESE LIMITS SHOULD BE REVIEWED WITH FIRESTONE.

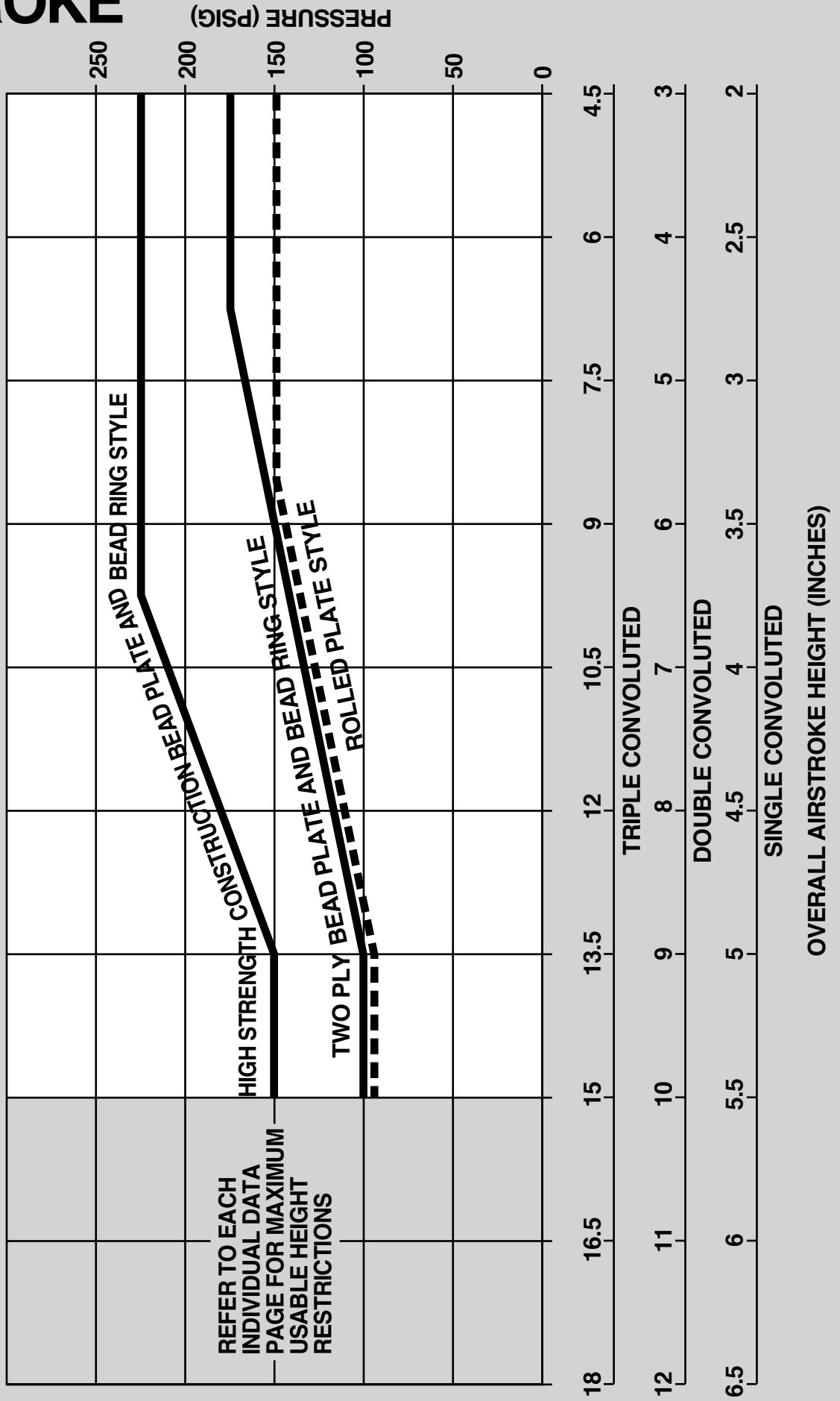

# AIRSTROKE™ ACTUATOR PROBLEM SOLVERS

**GATE VALVE OPERATOR**

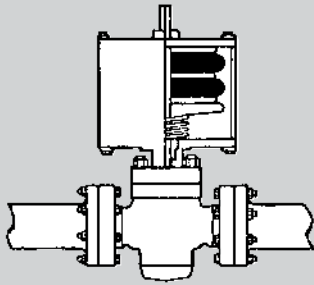

**GLUING PRESS**

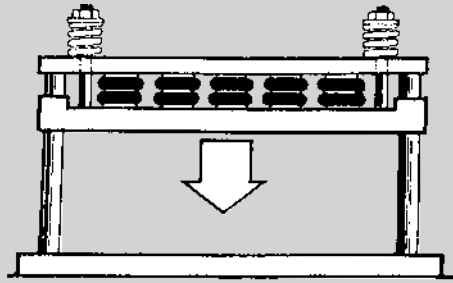

**WEB TENSIONING DEVICE**

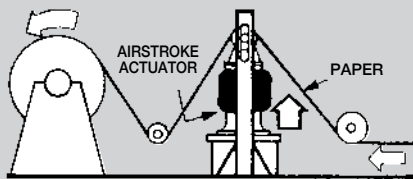

**DIE STRIPPER**

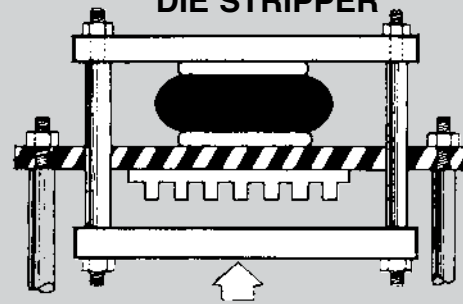

**KNIFE SPRING ACTUATOR**

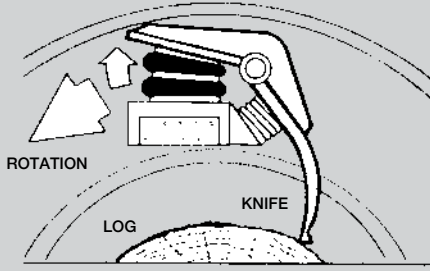

**QUENCH TANK ACTUATOR**

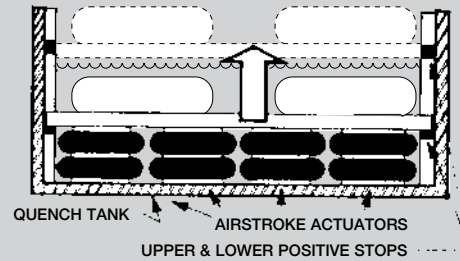

**PAPER SIZING PRESS**

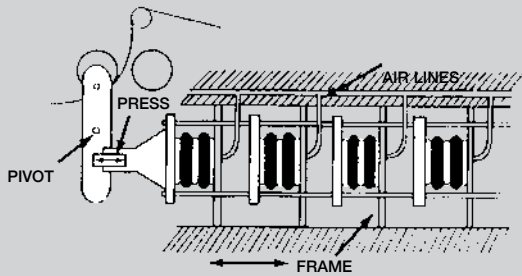

**PICKLING TANK ACTUATOR**

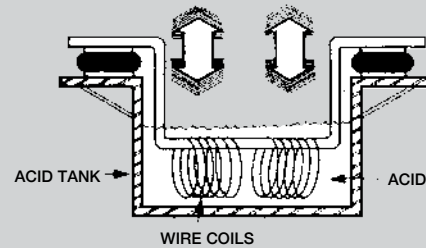

**QUICK LOCK DEVICE**

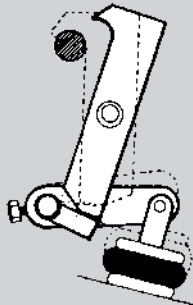

**PRESSURE ROLL FOR CALENDER**

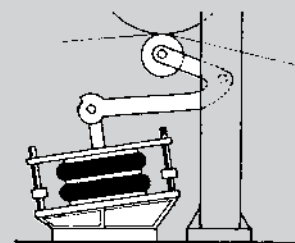

# AIRSTROKE™ ACTUATOR PROBLEM SOLVERS

**MISSILE ASSEMBLY FIXTURE**

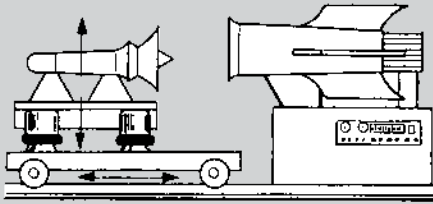

**CORE STRAIGHTENER**

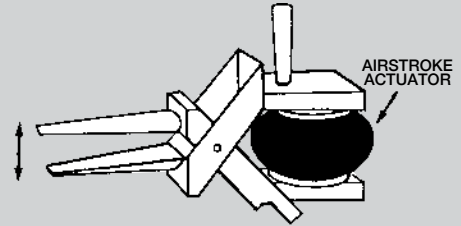

**BELT TAKE UP**

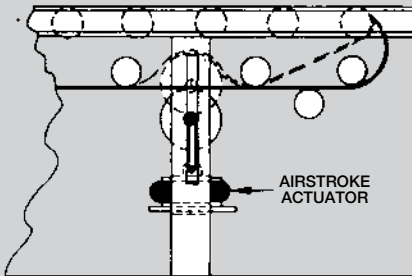

**ROLLER FRICTION BRAKE**

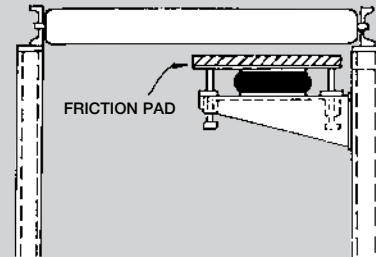

**PIPE INDEXING THREADING**

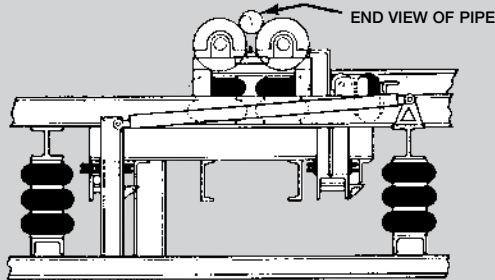

**OSCILLATING DOCTOR FOR PAPER CALENDER ROLL**

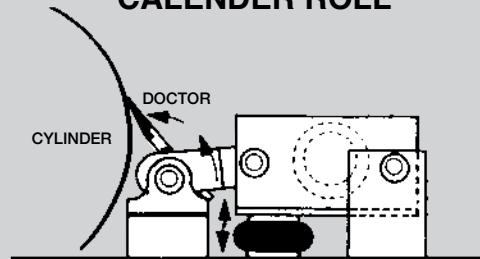

**FORMING PRESS**

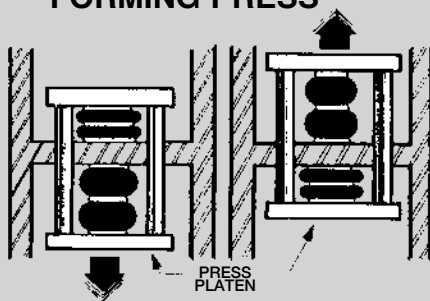

**CABLE TENSIONING DEVICE**

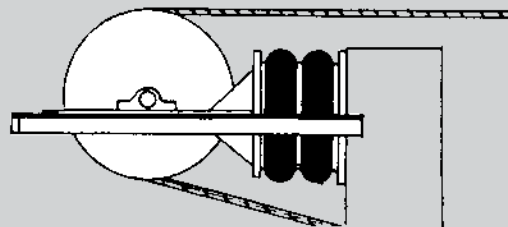

**BAG FLATTENER**

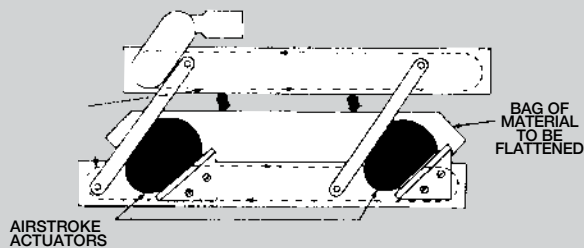

**TORSIONAL FRICTION BRAKE**

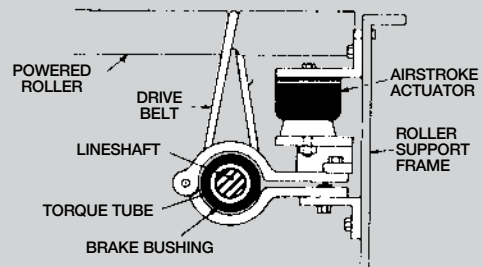

# AIRSTROKE™ ACTUATOR PROBLEM SOLVERS

## HINGED GATE

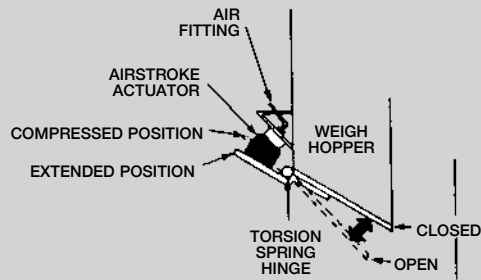

## HOT FOIL STAMPING PRESS

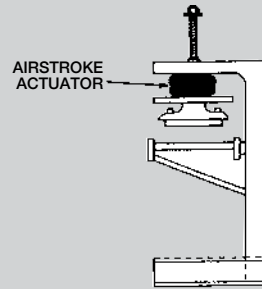

## ACTUATED HEAVY DUTY SEALER

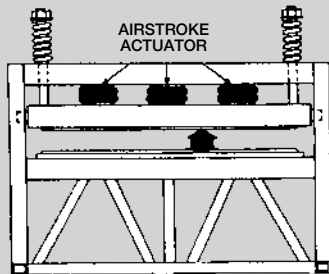

## PIVOTED CLAMPING DEVICE

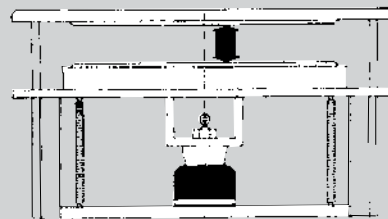

## AIRSTROKE ACTUATED ROLLER STOP

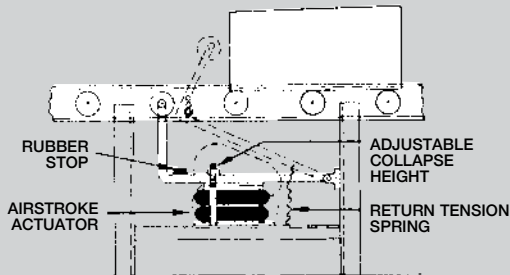

## HINGED ACTUATED GRAVITY GATE

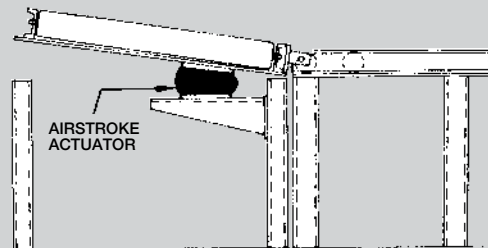

## VERTICAL ACTUATED DRIVE TABLE

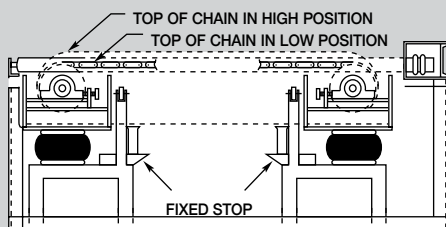

## SCISSOR LIFT

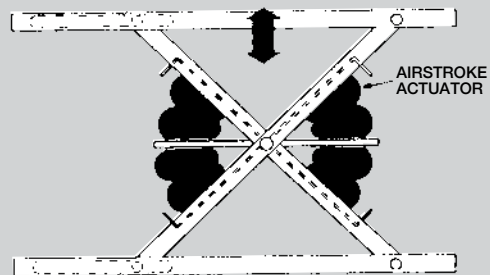

## CASE PACKER

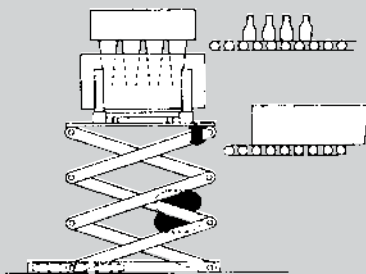

## CONVEYOR TRANSFER ACTUATOR

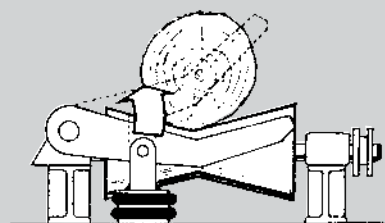

# AIRMOUNT™ VIBRATION ISOLATION

## SELECTION AND ISOLATION FORMULA

Refer to the selection guide on page 33 for Airmount load and isolation capabilities. Follow this procedure:

### 1. LOAD CAPACITY

Select one or two Airmounts that can support the load at each mounting point. It is normally best to design for pressures in the 60 to 80 psig range. Consider only the 1M1A-0 and the single and double convoluted types at first. Please notice that in the range of 210 to 63,890 pounds you will, in most cases, find both a single and double convoluted style part which will support the load.

### 2. DETERMINE ISOLATION EFFECTIVENESS

Select the disturbing frequency that is closest to the actual forced frequency (400, 800, or 1500 cpm). Then check the percentage of isolation for the parts that were selected in 1 above.

### 3. DETERMINE DESIGN HEIGHT

THE AIR SPRING SHOULD BE USED AT THE DESIGN HEIGHT GIVEN. The double convoluted part is used at a design height somewhat higher than its single convolution equivalent. Make sure that the design height falls within the height restrictions. Also, the double convoluted part will show a higher percentage of isolation (less transmitted vibration) than the single convoluted air spring. The reason for this is that the double convoluted part has a greater internal volume of air than the single convoluted version of the same size. At disturbing frequencies in the 400 to 800 cpm range, the double convoluted part is a significantly better vibration isolator than the single convoluted part. At disturbing frequencies of 800 to 1500 cpm, the gap closes considerably. At frequencies of 1500 cpm and above, the difference is negligible.

### 4. DETERMINE EXACT INTERNAL PRESSURE AND ISOLATION EFFECTIVENESS

The chances are that your specific vibration problem does not fall neatly into the load and disturbing frequency criteria as presented in the selection guide.

Therefore, once a preliminary part selection has been made, turn to the individual data page for that part in order to determine the specific internal pressure required and the percentage of isolation attainable.

## CONSIDER THIS EXAMPLE:

Isolate a vibrating screen which weighs a total of 16,400 pounds, preferably with *one* isolator at each corner. The vibrating mechanism is rotating at a speed of 850 rpm (cpm) with a total stroke of 5/16 inch.

- a. Determine the load at each mounting point:

$$\frac{16,400}{4} = 4,100 \text{ lbs.}$$

Scan down the 80 psig load column in the selection guide. It appears that either a #19 or a #22 will support the load at a pressure between 60 and 80 psig.

- b. Determine Isolation Effectiveness.

Read the % of Isolation at 800 cpm for the #19 and #22 (since 800 is closest to our machine speed of 850 cpm). A #19 is at 96.0% and a #22 is at 98.2%. Looking at isolation effectiveness in terms of % TRANSMISSION, the #19 will transmit 100 - 96.0, or 4.0% of the vibrations. A #22 will transmit 100 - 98.2, or 1.8% of the vibrations. So, even though there does not seem to be much difference between 96.0% and 98.2% isolation, the #22 is in fact a better isolator by approximately a factor of two when comparing transmitted vibration.

- c. Determine Design Height.

Let's say we have chosen the #22 because 96.0% isolation for a #19 is considered to be too low. A #22 should be used at 9.5 inches as shown in the second column on page 33.

- d. Determine Exact Internal Pressure and Isolation Percentage.

Turn to page 65 for detailed information on the #22.

- a) What exact pressure will be required to support the load of 4,100 lbs? Refer to the information in the block entitled "Dynamic Characteristics at 9.5 in Design Height."

$$\frac{4,280 \text{ lbs.}}{80 \text{ lbs/in}^2} = 53.5 \text{ in}^2 = \text{effective area @ 9.5 inches @ 80 psig}$$

Divide the actual load by the effective area:

$$\frac{4,100 \text{ lbs.}}{53.5 \text{ in}^2} = \underline{76.6} \text{ psig required to support 4,100 lbs. at 9.5 inches}$$

# AIRMOUNT™ VIBRATION ISOLATION

b) What exact isolation will be attained?

Use the formula:

$$\% \text{ Transmission} = \frac{100}{\left(\frac{f_f}{f_n}\right)^2 - 1}$$

Where:  $f_f$  = Forced Frequency  
 $f_n$  = Natural Frequency

The forced frequency is 850 cpm. Read the natural frequency from the line at the load and pressure closest to the actual situation, or 106 CPM (@ 80 psig and 4,280 lbs.):

$$\% \text{ Transmission} = \frac{100}{\left(\frac{850}{106}\right)^2 - 1}$$

% Transmission = 1.6%  
 % Isolation = 100 - % Transmission  
 % Isolation = 100 - 1.6  
 % Isolation = 98.4%

Notice that the natural frequency of an Airmount changes only slightly with variations in pressure and load. Therefore, when working at pressures other than 40, 60, 80, or 100 psig, % isolation can be calculated quite accurately using the "closest" natural frequency and the formula above.

## DYNAMIC SPRING RATE FORMULA

Spring rate is a different matter. Unlike most conventional springs, the rate of an Airmount is not constant. It is a function of the change in effective area, volume, and pressure from design height. To determine the rate of an Airmount, use the following formula:

$$K = \frac{\left[ [P_g + 14.7] \left[ A_c \left( \frac{V_1}{V_c} \right)^{1.38} - A_e \left( \frac{V_1}{V_e} \right)^{1.38} \right] - 14.7(A_c - A_e) \right]}{1 \text{ inch}} \text{ lbs}$$

WHERE:

$K$  = Vertical Spring Rate in lbs./inch  
 $P_g$  = Gauge Pressure at design height  $\left(\frac{\text{lbs}}{\text{in}^2}\right)$   
 $A_c$  = Effective Area at 1/2 inch below design height (in<sup>2</sup>)  
 $A_e$  = Effective Area at 1/2 inch above design height (in<sup>2</sup>)  
 $V_1$  = Internal Volume at design height (in<sup>3</sup>)  
 $V_c$  = Internal Volume at 1/2 inch below design height (in<sup>3</sup>)  
 $V_e$  = Internal Volume at 1/2 inch above design height (in<sup>3</sup>)

Consider the same #22 example: What is the vertical spring rate with a load of 4,100 pounds at a design height of 9.5 inches? Refer to the static data chart on page 65. Again, our "closest" pressure is 80 psig, so we'll need to read the appropriate data from the 80 psig curve.

The 80 psig information at 1/2 inch above design height would fall at the 10.0 inch height line, and 1/2 inch below design height would fall at the 9.0 inch height line. (In this example, we can read loads from the force table). The information at design height is located in the "Dynamic Characteristics Block." So,

$K$  = Unknown

$P_g$  = 76.6 psig (see page 13)

$$A_c = 58.4 \text{ in}^2 = \left(\frac{4,670 \text{ lbs.}}{80 \text{ lbs/in}^2}\right)$$

$$A_e = 47.6 \text{ in}^2 = \left(\frac{3,810 \text{ lbs.}}{80 \text{ lbs/in}^2}\right)$$

$V_1$  = 782 in<sup>3</sup>

$V_c$  = 752 in<sup>3</sup>

$V_e$  = 809 in<sup>3</sup>

$$K = \frac{\left[ [76.6 + 14.7] \left[ 58.4 \left( \frac{782}{752} \right)^{1.38} - 47.6 \left( \frac{782}{809} \right)^{1.38} \right] - 14.7(58.4 - 47.6) \right]}{1 \text{ inch}} \text{ lbs}$$

$$K = \frac{\left[ [76.6 + 14.7] \left[ 58.4 \left( \frac{782}{752} \right)^{1.38} - 47.6 \left( \frac{782}{809} \right)^{1.38} \right] - 14.7(58.4 - 47.6) \right]}{1 \text{ inch}} \text{ lbs}$$

$K$  = 1,324 lbs/inch

## NATURAL FREQUENCY FORMULA

Once the spring rate is determined, calculate the Airmount natural frequency (for an undamped system) as follows:

$$f_n = 188 \sqrt{\frac{K}{L}}$$

Where:

$f_n$  = Natural Frequency in cycles per minute (cpm)

$K$  = Rate (lbs/inch)

$L$  = Load (pounds)

in our example:

$$f_n = 188 \sqrt{\frac{1,324}{4,100}}$$

$f_n$  = 106.8 cpm

# AIRMOUNT™ VIBRATION ISOLATION

Up to this point, only the weight and disturbing frequency have been discussed. THERE ARE MANY OTHER IMPORTANT CONSIDERATIONS:

## CENTER OF GRAVITY

An Airmount isolation system is inherently soft (easily deflected); therefore, precautions must be taken to ensure that the system is stable. First, consider the location of the center of gravity (c.g.). Ideally, the Airmounts should be located on the same plane (parallel to the ground) as the center of gravity. Where this is not possible, follow this guideline: The distance between the most narrow mounting points should be at least twice the height of the center of gravity.

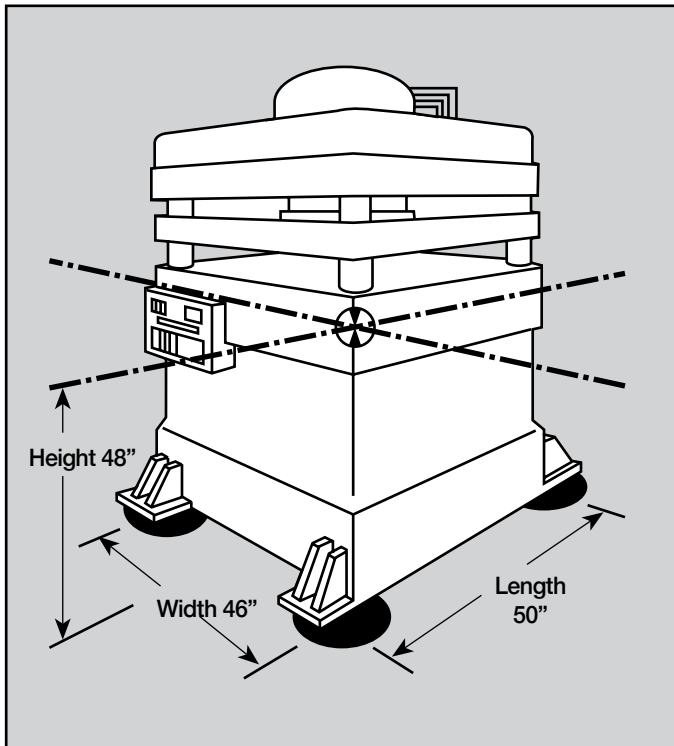

In the above example, the most narrow distance between two Airmounts is 46 inches. The height to the c.g. is 48 inches; therefore, this system does not meet our guideline. Two possible solutions would be:

1. Increase the base dimensions to meet our guideline by increasing both the width and length to at least 48 x 2 or 96 inches.
2. Locate the Airmounts at the c.g. as shown above (in the next column).

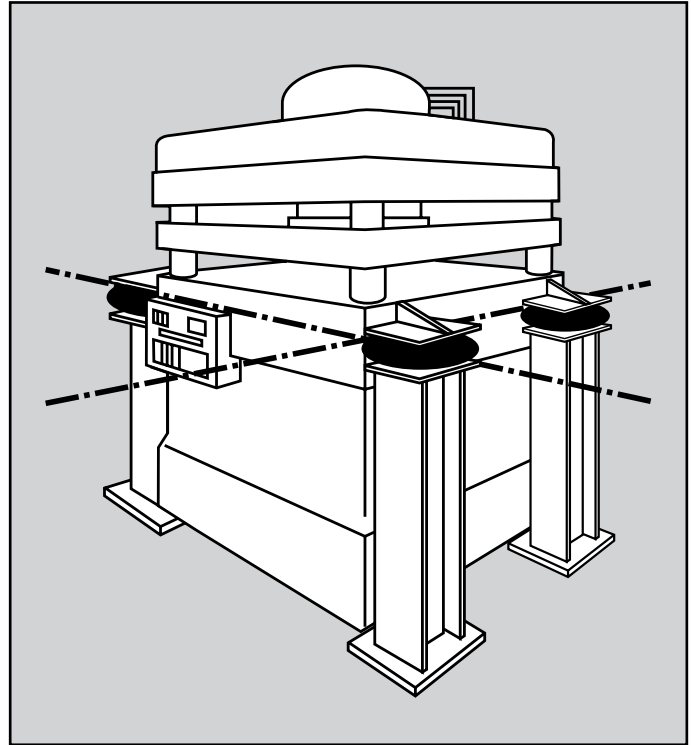

## LATERAL RATES AND STABILITY

Single and double convoluted air springs **SHOULD BE USED AT THE DESIGN HEIGHTS GIVEN**, because that is the point of maximum lateral rate or stability. The lateral rate *decreases* as the Airmount height *decreases*. Consider a #22 again at 80 psig:

Height	Lateral Rate	Vertical Rate
9.5 inch (design height)	325 lbs/in	1,373 lb/in
8.5 inch	212 lbs	—
7.5 inch	Unstable	—

Notice that the #22 becomes unstable in the horizontal or lateral direction when moving down only two inches from design height.

# AIRMOUNT™ VIBRATION ISOLATION

At design height and without an auxiliary reservoir, the single and double convoluted parts follow this pattern; i.e., the lateral rate varies from  $1/5$  to  $1/2$  of the vertical rate (only the larger high strength parts get as high as  $1/2$ ). Notice the #22 is approximately  $1/4$ <sub>(1.373)</sub><sup>(325)</sup>. Going back to the original example of a vibrating screen which weighs 16,400 lbs. mounted on four #22's (@ 9.5 inches), a side load of 1,300 pounds (325 x 4) would deflect the entire suspended mass by one inch.

## TRIPLE CONVOLUTED AND REVERSIBLE SLEEVE TYPE PARTS

Both of these types are unstable laterally (except for the 1M1A). Due to low natural frequencies, both can be excellent isolators; however, do not use these two types as Airmount isolators without consulting Firestone (for special guidelines and precautions).

## DESIGN ENVELOPE

Adequate clearance should be provided around the Airmount to prevent puncturing or rubbing of the bellows. The maximum diameter @ 100 psig for each Airmount (bellows) is shown just above the cross sectional view of the air spring.

## SAFETY STOPS

It is normally recommended that positive stops be installed *in all directions*; i.e., into compression, extension, and laterally. Positioning of the vertical stops depends upon the amplitude of movement, both during normal operation and startup and shutdown. A good "rule of thumb" is  $\pm 1/2$  inch from design height for vertical stops and also  $\pm 1/2$  inch (horizontally) for lateral stops.

## INITIAL INSTALLATION

NEVER use Airmounts to lift equipment into place, due to the lateral instability at lower air spring heights as discussed previously. Equipment should be rested on stops set *slightly* below design height and raised into position for isolation.

## STARTUP AND SHUTDOWN/ RESONANCE AND AMPLIFICATION

Resonance is the condition where the forced frequency of the vibrating system is at the natural frequency of the suspension. When this happens, AMPLIFICATION of movement occurs. Going back to our vibrating screen example again, if the normal stroke is  $5/16$  of an inch, during startup and shutdown (as the machine goes through resonance), the amplitude of movement will be multiplied somewhat. So, while the machine is building up to speed and slowing down, the stroke may be amplified in the range of  $1/2$  to  $1 1/2$  inches. The longer the machine takes to go through resonance (to build up to, or slow down from full operating speed), the larger the amplitude of movement.

## ISOLATING AN UNBALANCED MASS

The primary concern in this case is the amplitude of movement. It is dependent on:

- 1) The ratio of the unbalanced moving mass to the total suspended mass, and
- 2) The ratio of the speed of the unbalanced moving mass (forced frequency) to the natural frequency of the Airmounts.

The addition of damping to the isolation system (shock absorbers) will reduce the large amplitude of movement experienced during resonance.

If the amplitude of movement is too great, one possible solution would be to add an inertia base in order to increase the ratio of the total suspended mass to the moving unbalanced mass. A good "rule of thumb" is 10:1, respectively.

## LOW PRESSURE OPERATION

The lateral rate of a single and double convoluted style Airmount *decreases* with decreasing internal air pressure (becomes unstable). Consult Firestone if you plan on operating an Airmount at less than 40 psig.

## EFFECT OF AN AUXILIARY RESERVOIR

There is a direct relationship between natural frequency and isolation effectiveness. Generally, the lower the natural frequency, the better the isolator (or higher percentage of isolation). As previously mentioned, a double convoluted Airmount has a lower natural frequency than a single convoluted type (of the same size) because it has more internal air volume. We can use this principle to lower the natural frequency of an air spring by adding an auxiliary reservoir (pressure vessel) externally to the Airmount. This effectively increases the air spring volume and reduces its natural frequency.

In order for the reservoir to work properly, there must be a free flow of air between the Airmount and reservoir. Therefore, it should be mounted as close as possible to the Airmount. Additionally, a bead ring attachment is the best end closure choice as the hole in the upper mounting plate can be sized as large as the inside diameter of the bellows (at the top). A  $3/4$ " NPT air inlet will restrict the flow of air somewhat, but can be used as long as it is understood that there is some throttling effect.

Going back to the #22 example, an auxiliary reservoir of three times the internal volume of the air spring at design height (approximately 10 gallons) will reduce the natural frequency from 106.8 cpm to 90.2 cpm. The spring rate also decreases, from 1,324 lbs./inch to 944 lbs./inch.



# AIRMOUNT™ VIBRATION ISOLATION

## DAMPING

Damping is defined as the ratio:  $\frac{C}{C_C}$

WHERE: C = System Damping

$C_C$  = Critical Damping

The damping ratio inherent in an Airmount is in the order of .03. This damping number is so small that the formulas presented in this section assume it to be zero.

## PLUMBING SYSTEMS

There are three basic ways of controlling an air suspended isolation system:

**1. Tank Valve System** With a tank valve in each Airmount, each air spring is then inflated individually. The pressure in each must be checked periodically, because air will permeate through the bellows.

For an idea of the permeation rate, a #116 will lose approximately 30 psig over a period of one year (from 100 psig to 70 psig). Please see page 7 for a picture of a 1/4" NPT tank valve.

**2. Three Point Regulated System** The Airmounts can be connected directly to the factory compressed air system using pressure regulating valves. This eliminates the

need for periodic inspections. The air springs should always be connected in clusters so the mass is supported with only **THREE REGULATORS**. This is illustrated below (in the previous column) for both a four and eight Airmount system:

**3. Three Point Levelled System** Height control can be provided by adding height control valves to the system. Again, there should be only **THREE POINTS OF CONTROL**, or in this case, three leveling valves. Attempting to use more than three control points often results in the valves hunting or fighting one another. There are sensing systems available to control heights within  $\pm .001$  inch. Truck type leveling valves can provide accuracy to  $\pm 1/16$  inch. A three point, eight air spring, levelled system is illustrated below:

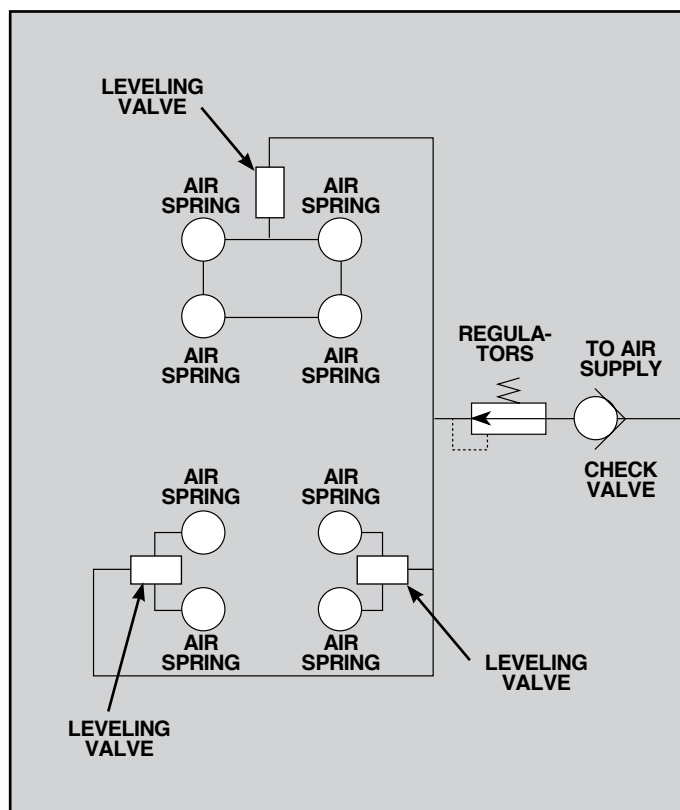
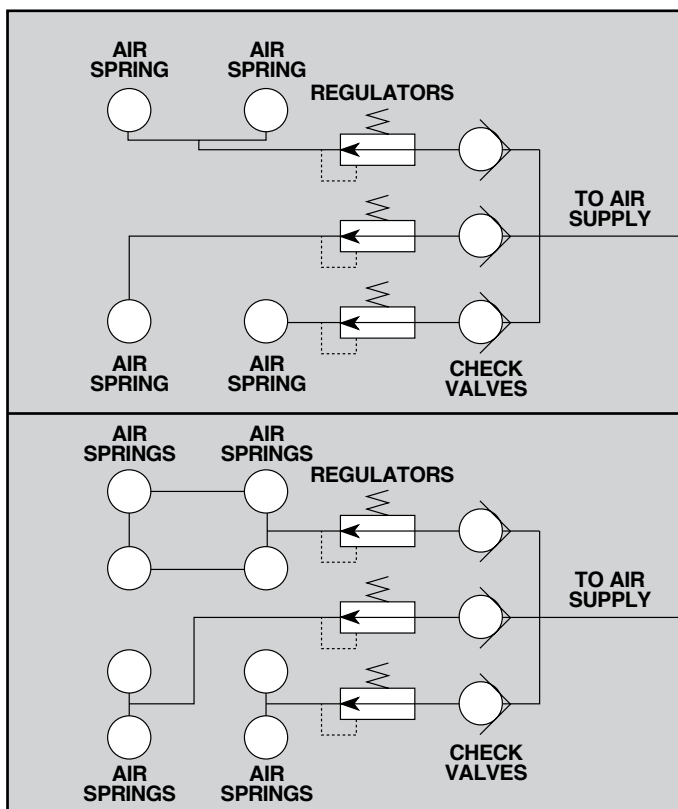

Description	Order No.
Height Control Valve	WC1-358-3592

An Airmount Design Parameter Worksheet can be found on page 111.

For More information ask your Firestone Rep for Technigram 107.

# AIRMOUNT™ VIBRATION ISOLATION

## ISOLATION CHART

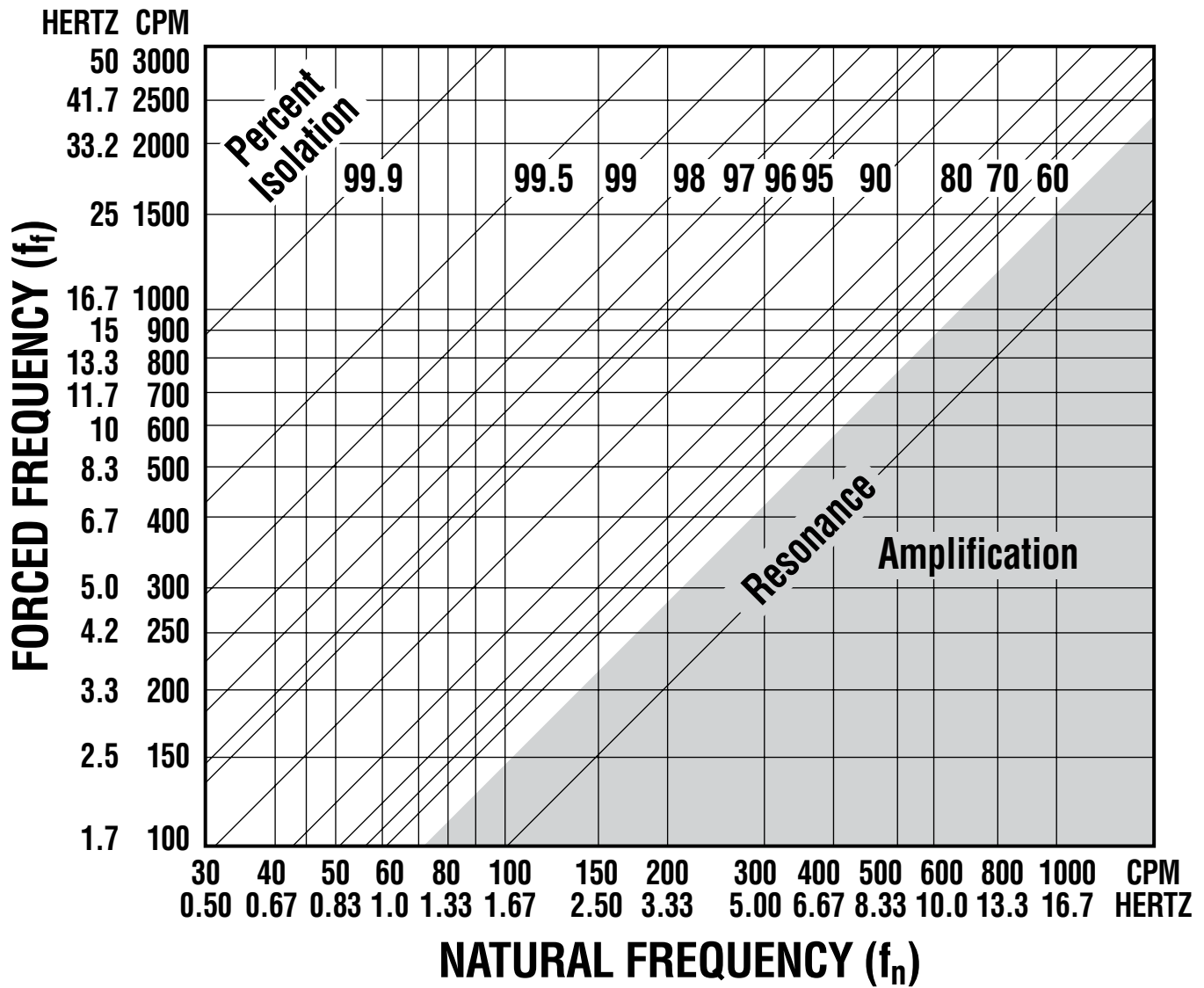

# AIRMOUNT™ ISOLATION PROBLEM SOLVERS

## VIBRATING PACKER

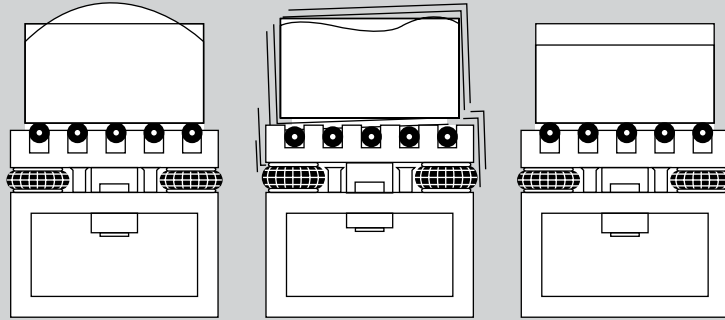

## BIN HOPPER

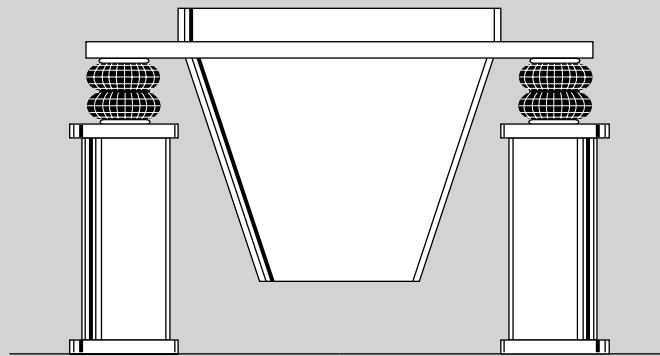

## COMPRESSOR

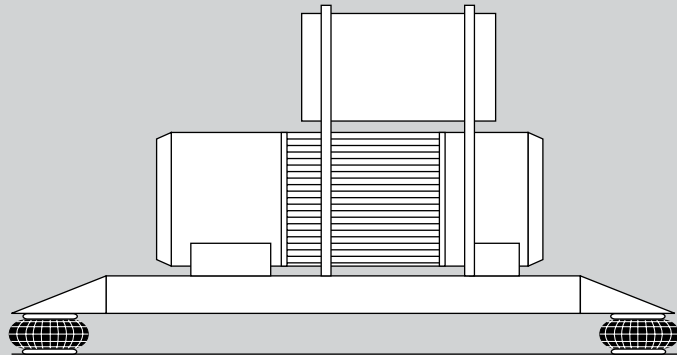

## COMMERCIAL LAUNDRY MACHINE

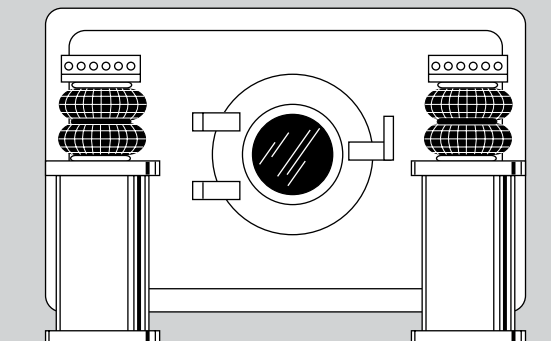

# AIRMOUNT™ ISOLATION PROBLEM SOLVERS

**CONTROL BOOTH**

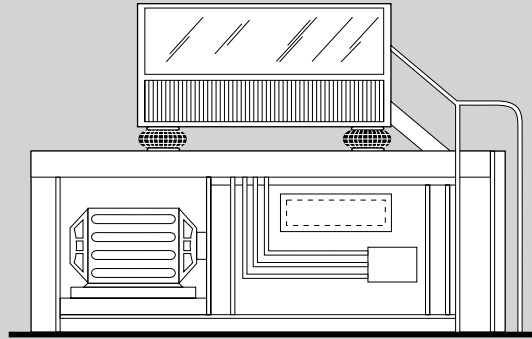

**VIBRATING SCREEN**

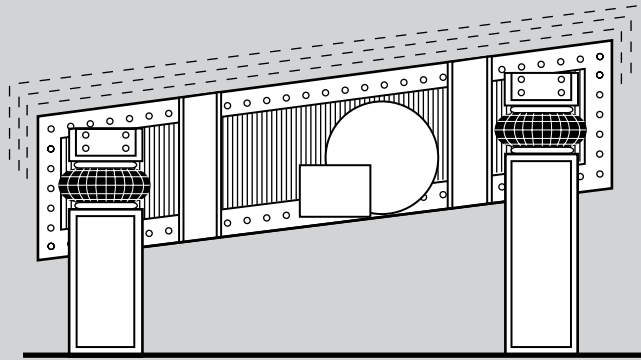

**BLOWER AND MOTOR**

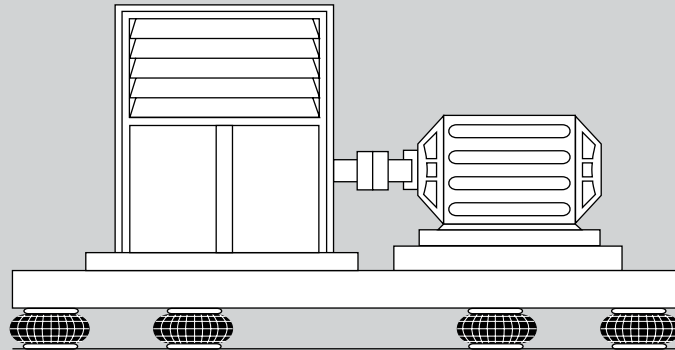

**CONTROL PANEL**

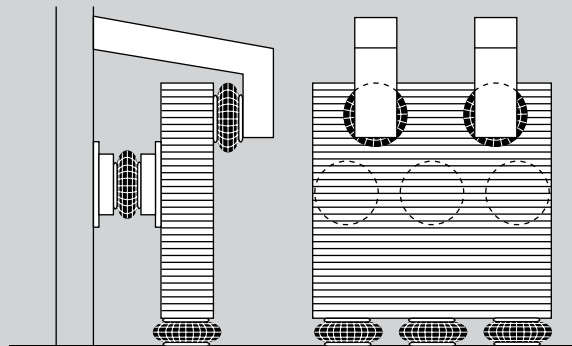

# MISCELLANEOUS APPLICATIONS

The air spring provides a unique solution for many actuation and isolation applications the world over. Besides the common applications, there are many that are not readily recognized because of the air spring's unique construction. Listed below are some miscellaneous applications.

## SHOCK IMPACT ISOLATION

The air spring is frequently used in shock impact isolation applications. This air spring application is commonly found in saw mills as the means to both absorb the shock of a falling log, and then by actuating the air spring, to lift and transfer a log onto a conveyor. Because of the properties of both air and rubber, the air spring is an ideal solution to this problem. Without it, the mechanism and surrounding structure would suffer fatigue and fail prematurely due to the intensity of the shock from the falling log. Refer to the problem solver section on the following pages for miscellaneous applications.

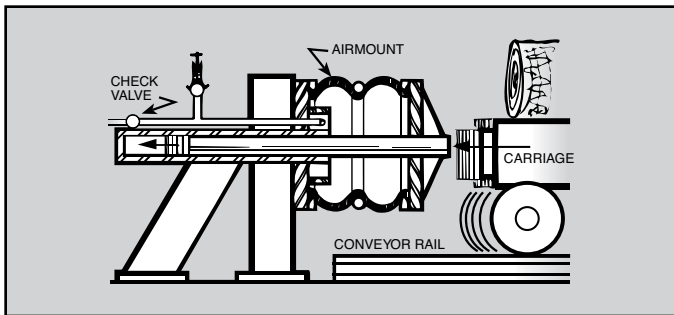

## PROTECTIVE BOOT AND FLEXIBLE CONNECTOR

An air spring bellows, with a bead ring type attachment, can be used as a protective boot or flexible connector. Due to the flexible construction of the air spring and the ability to handle both misalignment and angular movement, the air spring is a suitable solution to this problem. To protect the inner surface from the flow of material, an inner sleeve may be required. Refer to the problem solver section on the following pages for miscellaneous applications.

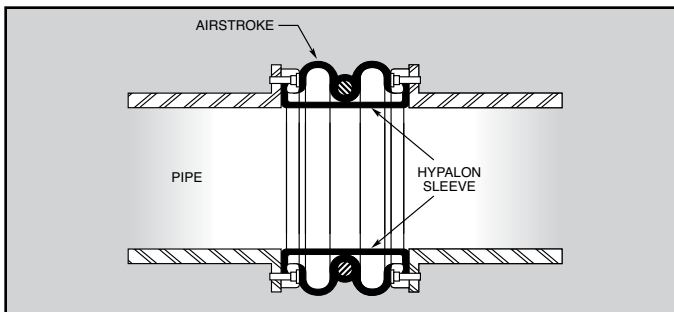

For more information, call your local stocking distributor or the Firestone applications engineer at [NAIndustrial@FSIP.com](mailto:NAIndustrial@FSIP.com).

## VACUUM PUMP

It is possible to drive an air spring mechanically in order to create a vacuum. The air spring can withstand a small amount of acceptable vacuum without injury to the bellows. The maximum amount of tolerable vacuum is dependent upon the bellows' size, height and whether it is a 2 ply or high strength air spring. It is generally best to use only the single convoluted air spring for this purpose. Refer to the problem solver section on the following pages for miscellaneous applications.

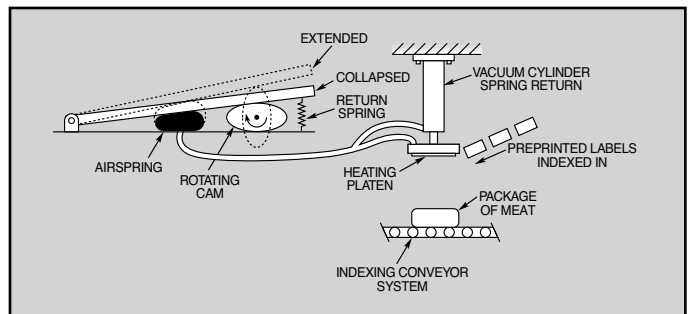

## INFLATABLE CHUCK

By restricting the height internally of a bead ring style air spring, the rubber walls will extend in an outward fashion. In this arrangement the air spring can be used as an inflatable chuck. The air will need to be introduced via the same mechanism that restrains the air spring's height. Refer to the problem solver section on the following pages for miscellaneous applications.

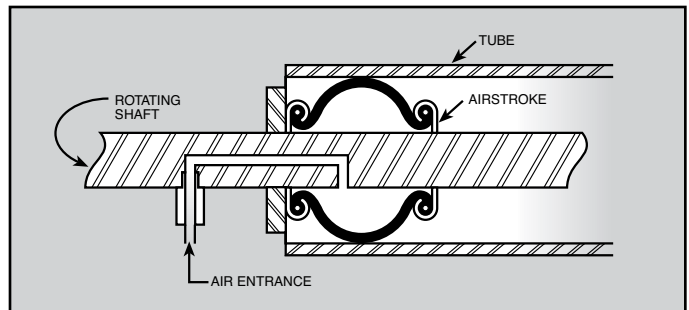

## CAM FOLLOWER

The introduction of an air spring as the cam follower can extend the life of the cam greatly. Surface wear is reduced by removing the rigidity and friction of typical cam followers. With this reduction of wear comes continually smooth operations and overall minimization of fatigue. Refer to the problem solver section on the following pages for miscellaneous applications.

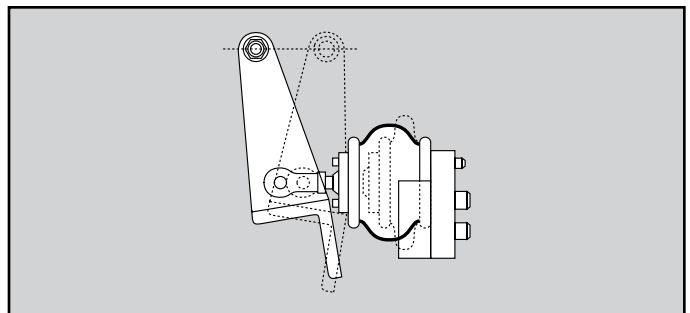

# MISCELLANEOUS PROBLEM SOLVERS

**ROBOTIC COUPLING**

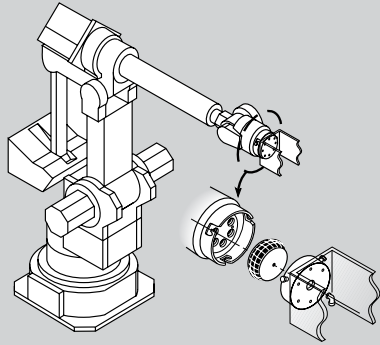

**CONVEYOR END STOP**

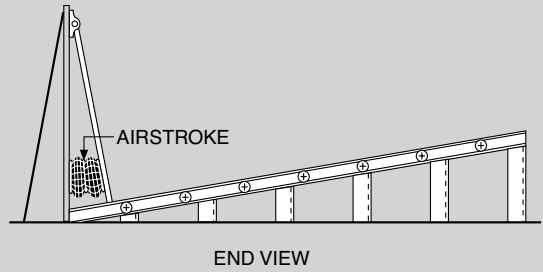

**MOUNTAIN/TRAIL BIKE**

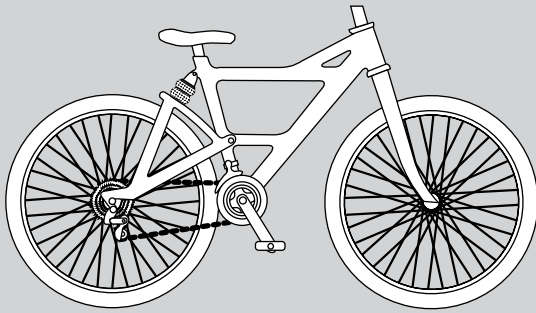

**SHOCK ABSORBER TEST SYSTEM**

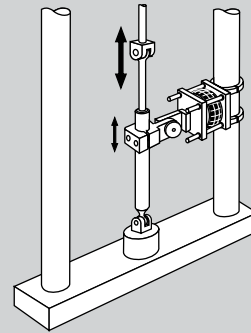

**SCREENING MACHINE COVER CLAMP**

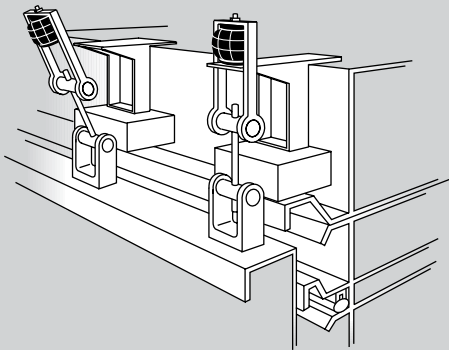

**PIPE CRAWLER**

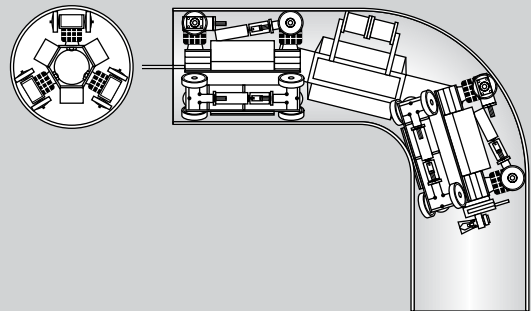

**DELICATE ELECTRONIC EQUIPMENT**

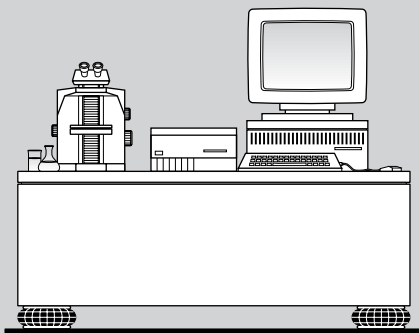

**VIBRATING SCREEN**

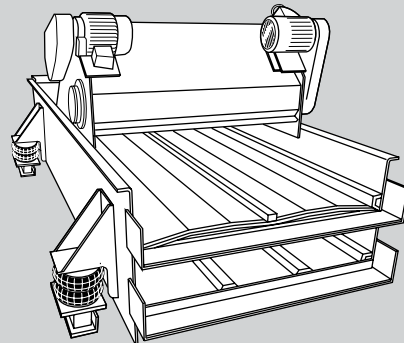

# MISCELLANEOUS PROBLEM SOLVERS

**SHEET WELDING CLAMP**

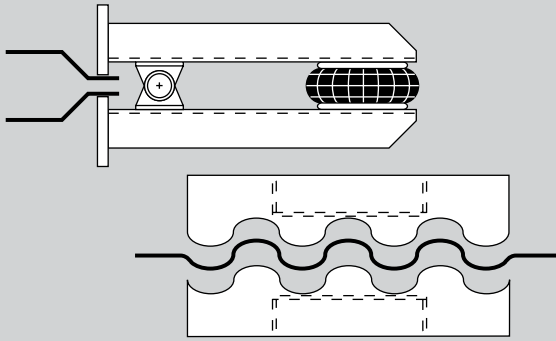

**SWASH PLATE MOTOR**

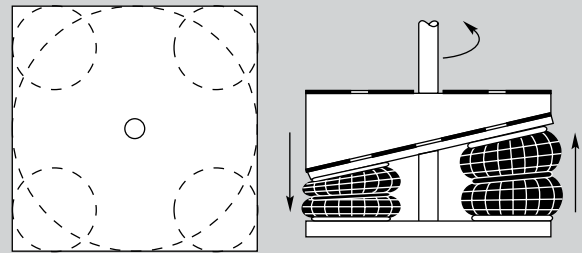

**PERFECT BOUND MAGAZINE CUTTER**

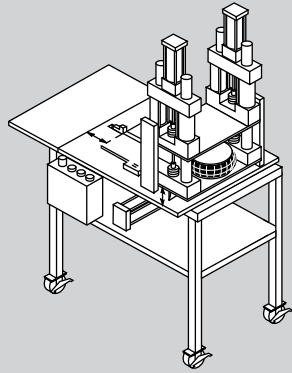

**WAVE POWER MODULE**

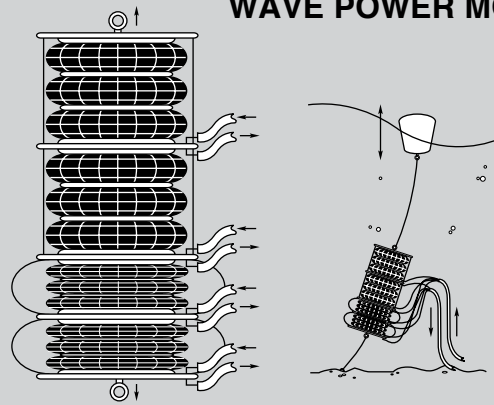

**CHECK VALVE LAPPING**

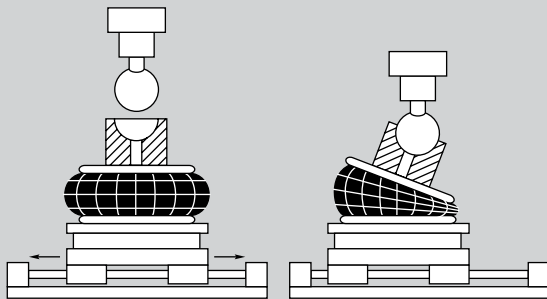

**SELF ALIGNING DEVICE**

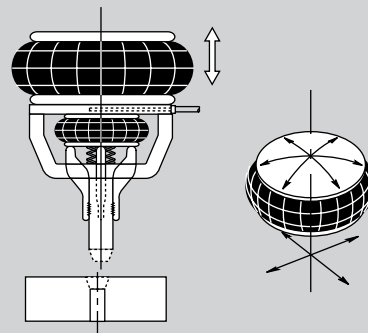

**AIR BLAST GENERATOR**

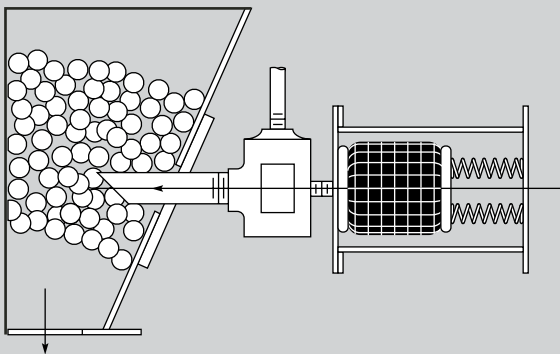

**SOLAR TRACKER**

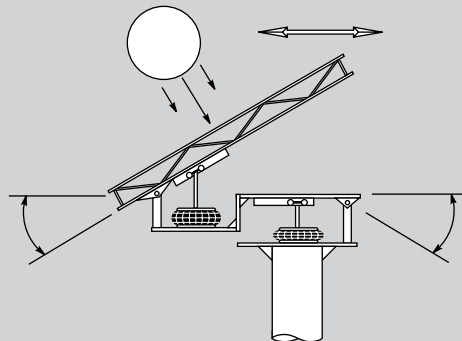

**Firestone AIRSTROKE™ ACTUATORS**

**END CLOSURE OPTIONS**

Style Number	Maximum Diameter at 100 PSIG (inches)	Minimum Height (inches)	Maximum Stroke (inches)	Maximum Usable Height (inches)	100* PSI Force <sup>†</sup> at Stroke of			High Strength Style Number	Pg. No.
					1 Inch (pounds)	3 Inches (pounds)	Maximum Stroke (pounds)		

Bead Plate Type	Dim. A (blind nut centers) (inches)	Dim. B (inches)	Bead Ring Type	Dim. C (bolt circle diameter) (inches)	Number of Bolts (each ring)
-----------------	-------------------------------------	-----------------	----------------	--	-----------------------------

**POLYACTUATOR**

50-P-10	1.97	0.45	0.4	0.85			69		35
70-P-13	2.75	0.63	0.4	1.03			132		36
120-P-25	4.72	1.35	0.8	2.05			516		37

**SHAPED SLEEVE**

1M1A-0	3.4	1.5	1.4	2.9	563		500		38
1M1A-1	3.45	1.5	2.0	3.5	613		469		39
2M1A	3.5	2.5	3.4	5.9	588	513	450		40
2M2A	2.3	1.2	1.0	2.2	175		175		41

**SINGLE CONVOLUTION**

16	6.0	1.9	1.4	3.3	1,163		725		42
131	6.5	2.0	2.1	4.1	2,063		1,063		43
160	7.2	2.1	4.3	6.4	2,338	1,875	1,425		44
110	8.3	2.1	3.0	5.1	2,613	1,288	1,175		45
116	9.1	2.0	3.1	5.1	3,363	1,713	1,625	117	46
116-1	9.6	2.0	4.2	6.2	3,725	2,800	1,825		47
115	10.1	2.2	2.9	5.1	4,388	2,600	2,275	124	48
19	12.9	2.0	3.5	5.5	8,400	4,663	3,288		49
19-.75	13.5	2.2	3.7	5.9	8,800	6,250	4,063		50
113	15.2	2.0	3.5	5.5	12,775	8,075	6,188	128	51
113-1	15.9	2.1	4.5	6.6	13,575	11,000	6,875	128-1	52
153-2	18.1	2.5	4.8	7.3	16,419	13,255	8,028		53
119 <sup>§</sup>	17.4	2.0	4.2	6.2	17,538	14,313	9,813		54
121 <sup>§</sup>	20.3	2.1	3.5	5.6	24,500	18,063	14,188		55
126 <sup>§</sup>	22.4	2.0	3.5	5.5	32,450	23,063	18,625		56
138-1.5	27.9	2.1	4.9	7.0	52,413	44,475	30,400		57
148-1	37.4	2.5	4.8	7.3	97,875	84,988	65,625		58

**DOUBLE CONVOLUTION**

268	6.4	3.0	3.1	6.1	1,813	1,100	1,025		59
267-1.5	6.5	3.0	4.0	7.0	2,082	1,667	895		60
224	8.0	2.8	4.7	7.5	2,888	2,125	1,213		61
26	8.6	2.8	5.7	8.5	3,438	3,288	1,188		62
274	9.9	3.1	6.0	9.1	4,925	3,524	810	202	63
20-2	10.4	3.0	8.0	11.0	5,156	4,691	2,653		64
22	12.9	3.2	6.9	10.1	8,975	8,088	4,625	210	65
22-1.5	13.7	3.0	8.1	11.1	9,600	8,738	4,788		66
21	15.1	3.2	6.9	10.1	12,875	11,638	7,088	205	67
21-2	16.0	3.0	8.7	11.7	14,163	13,338	7,313		68
233-2	15.5	3.0	10.4	13.4	13,708	13,205	7,375		69
28 <sup>§</sup>	17.4	3.4	6.7	10.1	18,750	16,500	10,663	201	70
203 <sup>§</sup>	20.0	3.5	7.0	10.5	26,750	24,000	16,138	218	71
29 <sup>§</sup>	22.7	3.3	7.5	10.8	33,625	30,500	21,600	207	72
200	26.0	3.5	7.1	10.6	44,625	41,625	31,563		73
215	27.9	3.5	8.6	12.1	53,125	50,000	35,200		74
248-2	37.4	4.2	9.1	13.3	97,750	92,625	67,488		75

**TRIPLE CONVOLUTION**

352	13.1	4.8	10.9	15.7	10,038	9,175	5,100		76
313	15.1	4.5	10.7	15.2	13,313	12,125	6,825	39	77
333	15.2	4.5	12.0	16.5	24,901	12,541	7,250		78
312 <sup>§</sup>	18.2	4.5	10.4	14.9	19,625	17,750	10,925	314	79
323 <sup>§</sup>	20.5	4.6	10.8	15.4	27,513	25,250	16,650	324	80
320 <sup>§</sup>	22.4	4.5	11.8	16.3	33,500	30,850	19,250	328	81
321	27.9	4.5	13.5	18.0	52,500	49,625	30,975	321	82
348-3	37.4	5.5	13.8	19.3	96,250	92,500	67,000		83

**REVERSIBLE SLEEVE**

4004	3.1	3.6	3.6	7.2	350	388	388		84
7002	4.2	3.5	2.5	6.0	888	825	825		85
7010	4.0	5.75	4.25	10.0	713	750	800		86
7012	5.0	5.0	4.5	9.5	863	938	950		87
110/70	5.7	4.5	4.9	9.4	1,213	1,138	1,113		88
1T14C-1	9.1	5.0	7.7	12.7	3,488	3,213	2,150		89
1T14C-3	9.0	5.8	8.2	14.0	3,663	3,188	1,863		90
1T14C-7	9.0	8.0	9.4	17.4	3,800	3,263	2,038		91
1T15T-1	11.2	4.0	6.7	10.7	6,263	5,463	3,638		92
1T15LP-3	11.1	6.0	10.0	16.0	6,338	5,525	3,538		93
1T15L-4	11.7	6.0	9.9	15.9	7,113	6,875	4,600		94
1T15M-0	12.8	4.3	7.0	11.3	7,125	6,938	4,800		95
1T15M-2	12.6	5.0	8.3	13.3	7,600	7,413	5,075		96
1T15M-4	12.6	6.0	10.5	16.5	7,838	7,163	5,025		97
1T15M-6	12.6	7.0	12.2	19.2	7,850	7,163	4,938		98
1T15M-9	12.7	8.5	15.1	23.6	8,063	7,313	5,263		99
1T19L-7	14.2	6.5	12.8	18.8	11,000	9,125	5,875		100
1T19L-11	14.2	8.0	15.4	23.4	10,750	9,125	6,375		101

**SEE INDIVIDUAL DATA PAGE**

1	1.75		4	4.50	6
1	1.75		4	4.50	6
1	1.75		4	4.50	6
1	1.75		4	4.50	6
1	2.75		4	5.31	6
1	2.75		4	5.31	6
3	3.50	1.75*	4	6.31	8
3	6.20	2.88	4	9.00	12
3	6.20	2.88	4	9.00	12
2	6.25		4	11.31	12
2	6.25		4	11.31	12
2	6.25		N/A	N/A	N/A
5	9.00	13.79	4	13.81	18
5	12.00	16.50	4	16.50	24
5	15.00	19.00	4	19.00	24
			4	23.50	32
			4	32.68	40

1	1.75		4	4.50	6
1	1.75		4	4.50	6
1	2.75		4	5.31	6
1	2.75		4	5.31	6
3	3.50	1.75*	4	6.31	8
3	3.50	1.75	4	6.31	8
3	6.20	2.88	4	9.00	12
3	6.20	2.88	4	9.00	12
2	6.25		4	11.31	12
2	6.25		4	11.31	12
2	6.25		4	11.31	12
5	9.00	13.79	4	13.81	18
5	12.00	16.50	4	16.50	24
5	15.00	19.00	4	19.00	24
			4	22.00	24
			4	23.50	32
			4	32.68	40

3	6.20	2.88	N/A	N/A	N/A
2	6.25		4	11.31	12
2	6.25		4	11.31	12
5	9.00	13.79	4	13.81	18
5	12.00	16.50	4	16.50	24
5	15.00	19.00	4	19.00	24
			4	23.50	32
			4	32.68	40

**SEE INDIVIDUAL DATA PAGE**

\*Values for the Polyactuators are based out of the 50 psi curve. Do not use polyactuator at more than 50 psi.  
<sup>†</sup> To determine Airstroke force at other pressures, divide force shown by 80 PSIG and multiply result by new pressure.  
<sup>§</sup> This is offered with a rolled plate. When using the rolled plate end closure option, add .7 inch to heights shown.

\*On plates with a 3/4 inch NPT air inlet, B dimension is 1.50 inch.



**Firestone AIRMOUNT™ ISOLATORS**

Style Number	Design Height	Load (at Design Height) at:			Natural Frequency (@ 80 PSIG) f <sub>n</sub> (cpm)	% of Isolation at Forced Frequency		
		**40 PSIG (pounds)	60 PSIG (pounds)	80 PSIG (pounds)		400 CPM %	800 CPM %	1500 CPM %

**POLYACTUATOR**

50-P-10	DO NOT USE 50-P-10 AS AN AIRMOUNT ISOLATOR							
70-P-13	DO NOT USE 70-P-13 AS AN AIRMOUNT ISOLATOR							

**SHAPED SLEEVE**

1M1A-0	2.5	210	330	450	220		91.8	97.8
1M1A-1	3.0	235	356	475	162	80.2	95.7	98.8
2M1A	DO NOT USE 2M1A AS AN AIRMOUNT ISOLATOR							
2M2A	2.0	95	140	184	210		92.6	98.0

**SINGLE CONVOLUTION**

16	3.0	420	640	880	237		90.3	97.4
131	3.5	550	850	1,170	181	74.4	94.6	98.5
160	5.5	650	1,010	1,390	124	89.4	97.5	99.3
110	4.5	650	1,010	1,390	162	80.2	95.7	98.8
116	4.5	850	1,330	1,830	163	80.2	95.7	98.8
116-1	5.5	940	1,410	1,930	139	86.3	96.9	99.1
115	4.5	1,210	1,880	2,540	151	83.4	96.3	99.0
19	5.0	1,690	2,640	3,730	168	78.6	95.4	98.7
19-.75	5.5	1,890	2,950	4,080	156	82.0	96.0	98.9
113	5.0	3,010	4,610	6,460	152	83.1	96.3	99.0
113-1	5.5	3,820	5,900	7,990	133	87.7	97.2	99.2
153-2	6.0	4,564	7,048	9,682	121	89.9	97.7	99.3
119 <sup>§</sup>	5.0	5,490	8,450	11,450	138	86.5	96.9	99.1
121 <sup>§</sup>	5.0	6,450	10,300	14,450	142	85.5	96.7	99.1
126 <sup>§</sup>	5.0	8,630	13,870	18,450	139	86.3	96.9	99.1
138-1.5	6.0	15,020	23,040	31,240	121	89.9	97.7	99.3
148-1	5.5	32,860	50,290	67,690	118	90.5	97.8	99.4

**DOUBLE CONVOLUTION**

268	5.5	515	787	1,062	145	84.9	96.6	99.1
267-1.5	6.0	566	871	1,194	129	87.6	97.2	99.2
224	6.5	730	1,130	1,530	126	89.0	97.5	99.3
26	8.0	590	980	1,360	123	89.6	87.6	99.3
274	8.5	990	1,540	2,130	116	90.7	97.8	99.4
20-2	10.0	1,184	1,848	2,531	97	93.7	98.5	99.5
22	9.5	2,060	3,170	4,280	106	92.4	98.2	99.5
22-1.5	10.5	1,930	3,030	4,130	106	92.4	98.2	99.5
21	9.5	3,030	4,750	6,540	105	92.6	98.3	99.5
21-2	10.5	3,460	5,350	7,280	95	94.1	98.6	99.6
233-2	11.25	3,413	5,631	7,691	89	95.0	98.8	99.7
28 <sup>§</sup>	9.5	4,590	7,010	9,590	101	93.2	98.4	99.5
203 <sup>§</sup>	9.5	7,210	11,100	14,970	97	93.7	98.5	99.6
29 <sup>§</sup>	9.5	9,780	14,860	20,060	92	94.4	98.7	99.6
200	9.5	13,290	20,390	27,330	93	94.2	98.6	99.6
211/215	10.5	15,840	24,140	32,550	86	95.1	98.8	99.7
248-2	11.0	30,830	47,720	63,890	83	95.5	98.9	99.7

**TRIPLE CONVOLUTION**

352	13.5	2,319	3,631	5,017	77	95.9	99.0	99.7
313	13.0	3,310	5,120	7,020	82	95.6	98.9	99.7
333	14.7	3,282	5,167	7,000	77	96.1	99.1	99.7
312 <sup>§</sup>	13.0	5,100	7,930	10,730	80	95.8	99.0	99.7
323 <sup>§</sup>	13.0	8,010	12,030	16,270	78	96.0	99.0	99.7
320 <sup>§</sup>	14.0	9,340	14,850	19,200	76	96.3	99.1	99.7
319/321	15.0	15,080	23,200	31,600	72	96.7	99.2	99.8
348-3	15.0	31,480	47,870	64,870	68	97.0	99.3	99.8

**REVERSIBLE SLEEVE**

4004	5.5	150	220	290	105	92.7	98.3	99.5
7002	4.5	310	480	650	114	91.2	97.9	99.4
7010	8.0	280	440	600	83	95.5	98.9	99.7
7012	8.5	360	590	790	75	96.3	99.1	99.7
110/70	7.25	430	670	910	94	94.2	98.6	99.6
1T14C-1	9.0	1,190	1,890	2,570	86	95.1	98.8	99.7
1T14C-3	10.0	1,180	1,810	2,450	81	95.7	99.0	99.7
1T14C-7	13.0	1,250	1,920	2,610	64	97.4	99.4	99.8
1T15T-1	7.0	2,100	3,220	4,370	97	93.7	98.5	99.6
1T15LP-3	12.0	2,040	3,140	4,220	74	96.5	99.1	99.8
1T15L-4	11.0	2,650	4,080	5,510	82	95.6	98.9	99.7
1T15M-0	7.5	2,670	4,120	5,540	94	94.1	98.6	99.6
1T15M-2	9.5	2,850	4,370	5,900	86	95.2	98.8	99.7
1T15M-4	12.0	2,770	4,210	5,690	71	96.8	99.2	99.8
1T15M-6	14.0	2,730	4,130	5,590	67	97.1	99.3	99.8
1T15M-9	17.0	2,770	4,250	5,680	58	97.8	99.5	99.8
1T19L-7	13.0	3,480	5,290	7,100	70	96.8	99.2	99.8
1T19L-11	17.0	3,411	5,151	6,911	63	97.5	99.4	99.8

**END CLOSURES**

**TYPE 1 bead plate**

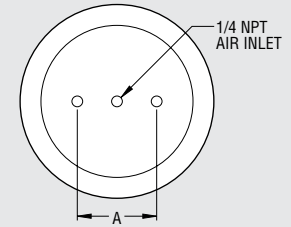

**TYPE 2 bead plate**

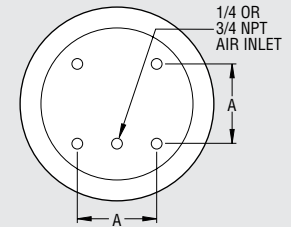

**TYPE 3 bead plate**

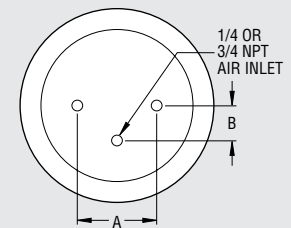

**TYPE 4 bead ring**

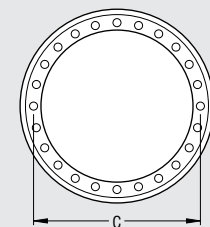

**TYPE 5 rolled plate**

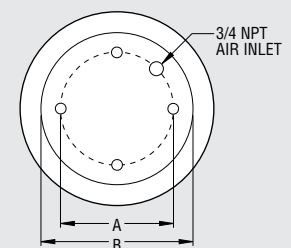

CONSULT FIRESTONE FOR USE AS AN AIRMOUNT

\*\*Airmount isolator air pressures below 40 PSIG should be reviewed with Firestone.  
†Except for 1M1A.



Description	Assembly Order No.
50-P-10	WA1-358-5676

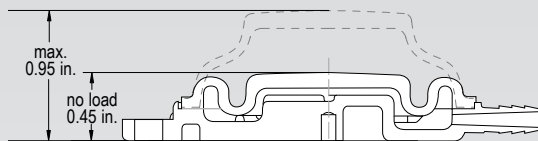
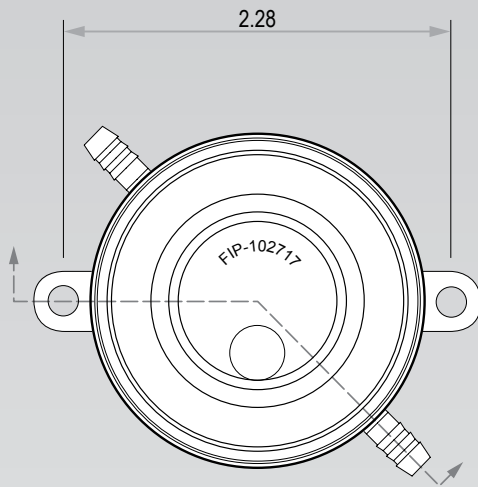

Use #8 or 4mm screws to mount through tabs.

Use .18 [4.6] ID nylon or equivalent tubing.

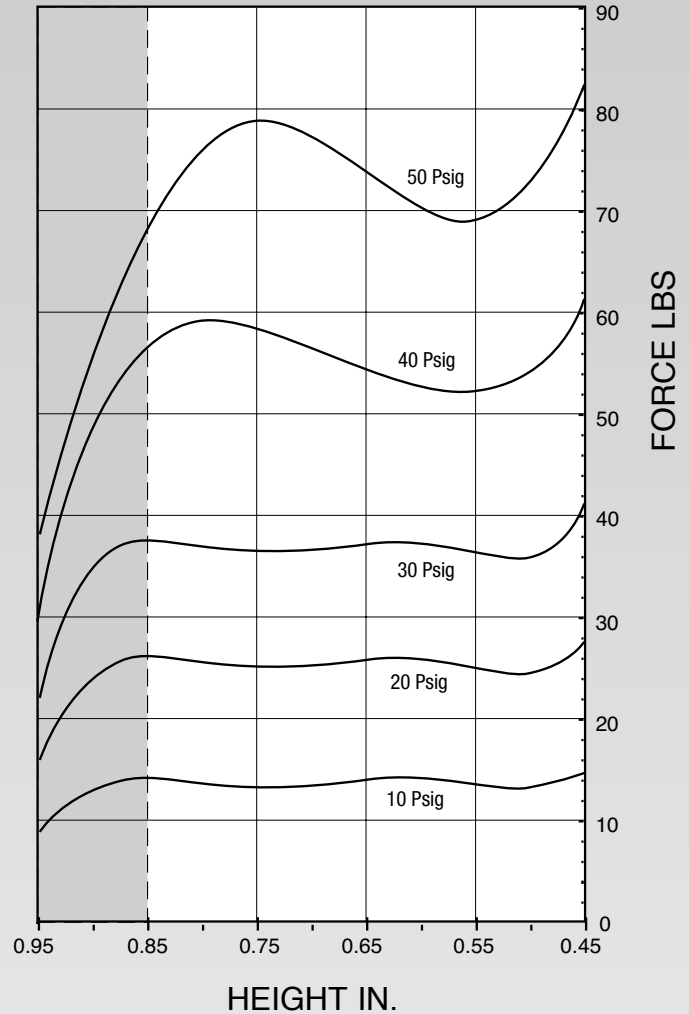

**NOTE:**  
Do not use as an Airmount isolator.

Assembly Height (in.)	Volume @ 50 PSIG (in <sup>3</sup> )	Pounds Force				
		@10 PSIG	@20 PSIG	@30 PSIG	@40 PSIG	@50 PSIG
.95		7	14	21	28	37
.85		13	25	38	58	69
.75		12	24	37	60	81
.65		13	25	38	56	76
.55		12	24	36	53	71
.45		14	27	41	62	85

Description	Assembly Order No.
70-P-13	WA1-358-5674

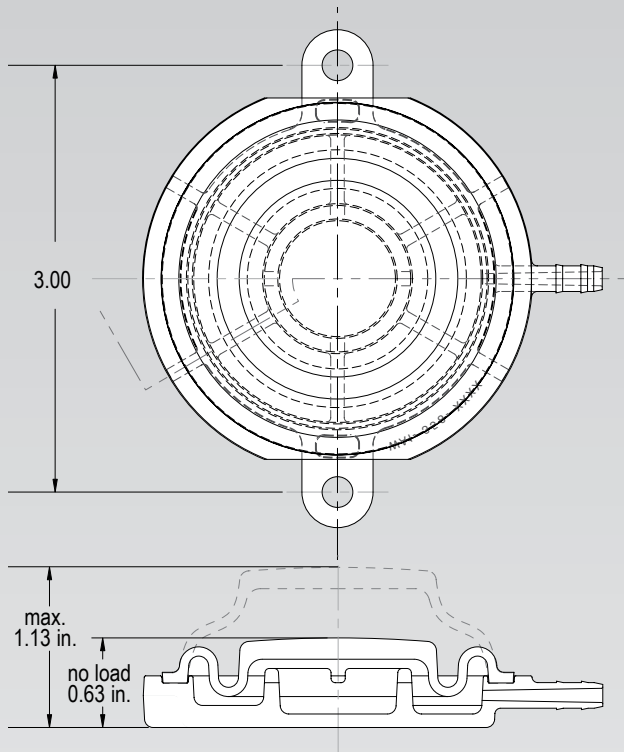

Use #8 or 4mm screws to mount through tabs.

Use .18 [4.6] ID nylon or equivalent tubing.

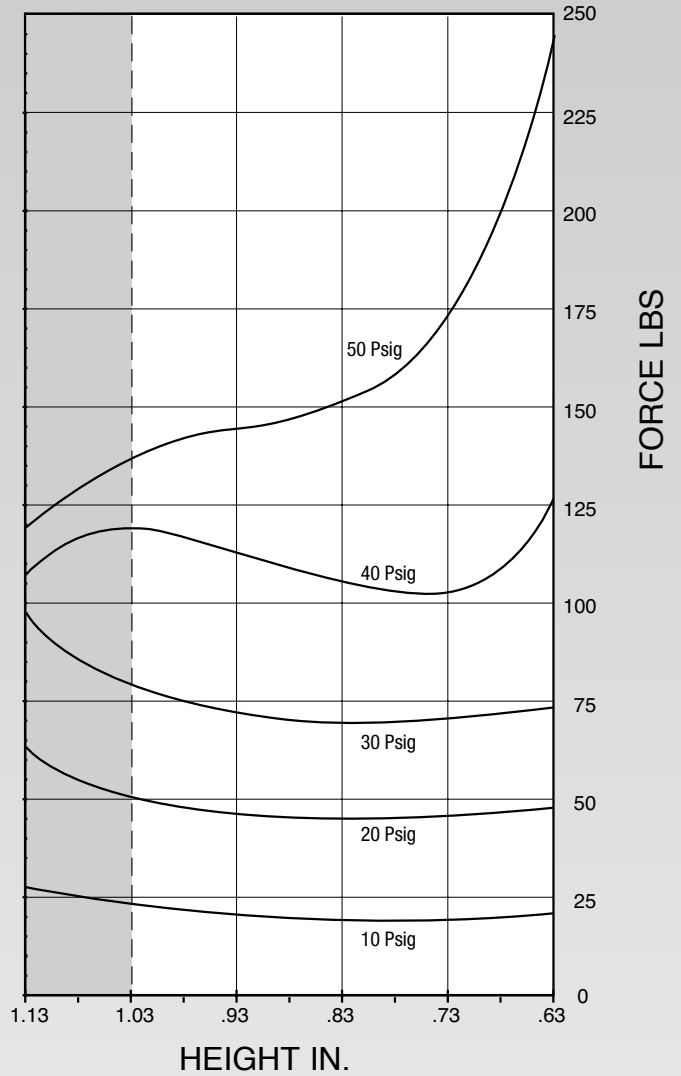

**Force Table (Use for Airstroke™ actuator design)**

Assembly Height (in.)	Volume @ 50 PSIG (in <sup>3</sup> )	Pounds Force				
		@10 PSIG	@20 PSIG	@30 PSIG	@40 PSIG	@50 PSIG
1.13		32	63	95	101	114
1.03		26	51	77	115	132
.93		24	49	73	109	139
.83		23	47	70	102	146
.73		23	46	69	100	174
.63		24	49	73	129	247

**NOTE:**

**Do not use as an Airmount isolator.**

Description	Assembly Order No.
120-P-25	WA1-358-5677

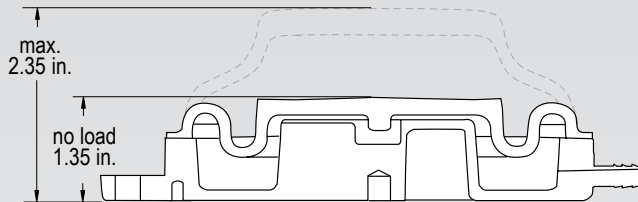
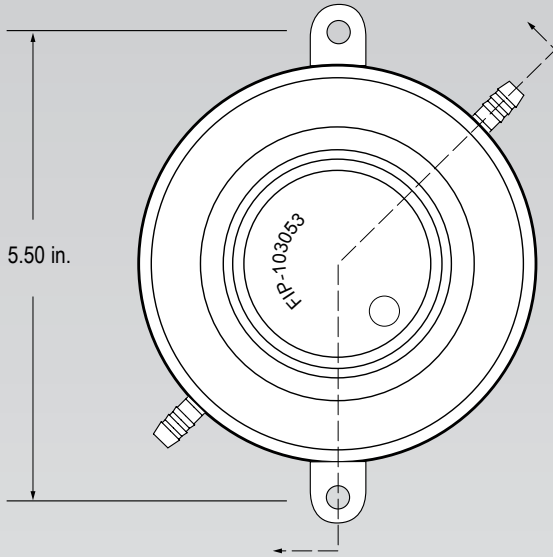

Use .25 in. or M6 screws to mount through tabs.

Use .25 in. [6.4] ID nylon or equivalent tubing.

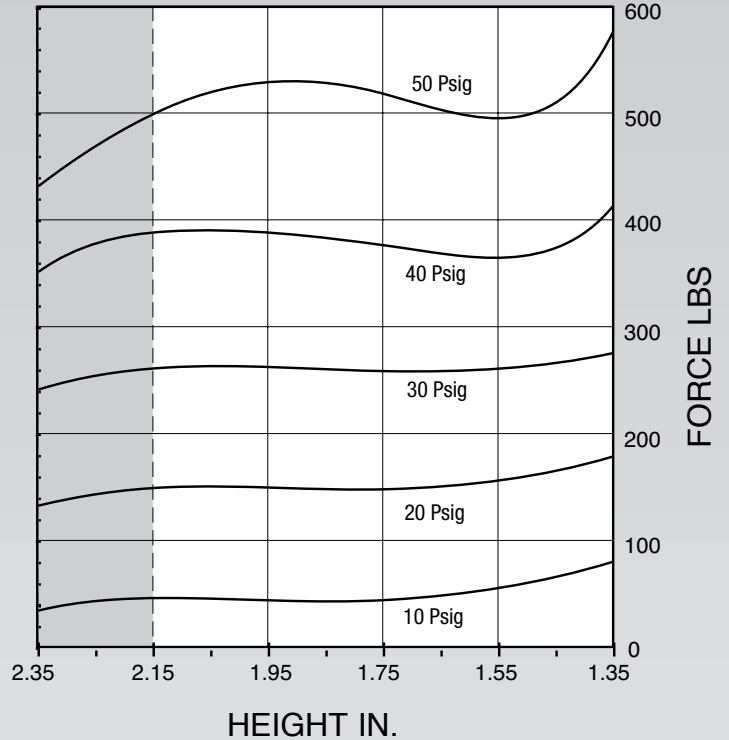

**Force Table (Use for Airstroke™ actuator design)**

Assembly Height (in.)	Volume @ 50 PSIG (in <sup>3</sup> )	Pounds Force				
		@10 PSIG	@20 PSIG	@30 PSIG	@40 PSIG	@50 PSIG
1.35		87	182	277	411	570
1.45		74	171	269	368	500
1.55		64	162	263	366	486
1.65		57	156	260	369	499
1.75		52	153	260	373	512
1.85		51	154	262	379	524
1.95		52	154	263	385	526
2.05		53	156	266	390	516
2.15		54	155	265	387	497
2.25		51	150	257	376	464
2.35		43	138	244	352	430

**NOTE:**

**Do not use as an Airmount isolator.**

Description		Assembly Order No.
Style 1M1A-0	Blind nut, 1/8 NPT, plastic stud	W02-358-3000
Two Ply Bellows	Blind nut, 1/8 NPT, brass stud	W02-358-3001
	Blind nut, 1/8 NPT, brass stud, stainless steel ring	W02-358-3005
Assembly weight .....		0.5 lbs.
Force to collapse to minimum height (@ 0 PSIG) ....		20 lbs.

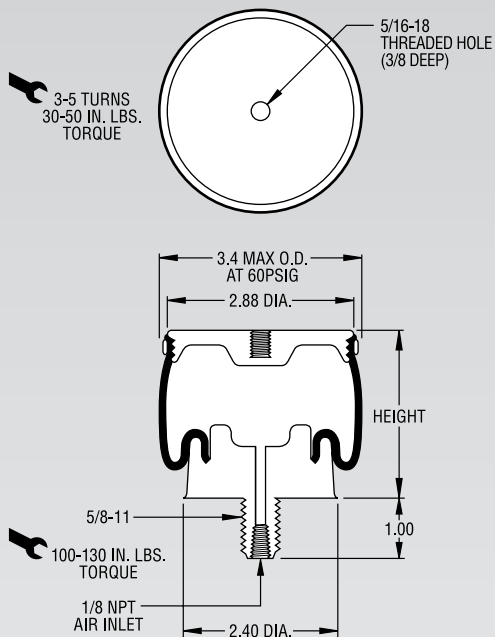

**NOTE:** Threads are not flush to piston face.

Recommended Design Position Static Pressure 0-100 psi

RECOMMENDED AIRMOUNT DESIGN HEIGHT 2.5 INCHES

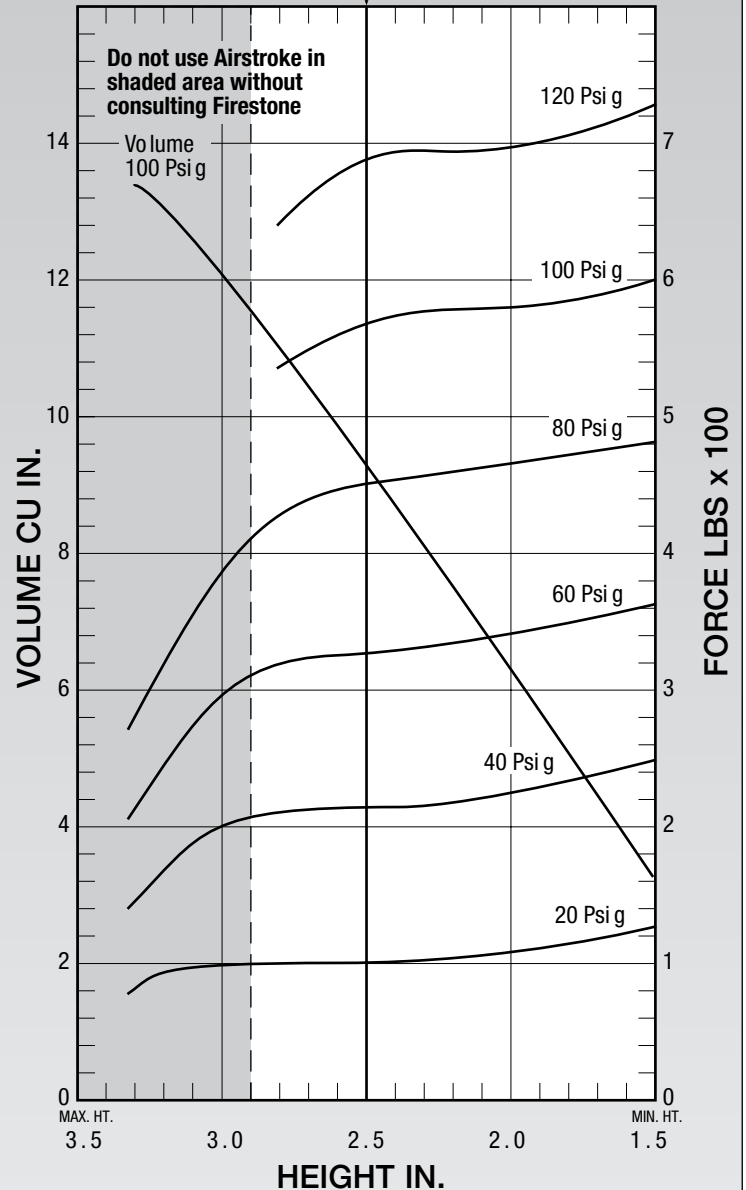

See page 12 for instructions on how to use chart.

Dynamic Characteristics at 2.5 in. Design Height (Required for Airmount isolator design only)				
Volume @ 100 PSIG = 9.2 in <sup>3</sup>			Natural Frequency	
Gage Pressure (PSIG)	Load (lbs.)	Spring Rate (lbs./in.)	CPM	HZ
40	210	336	235	3.92
60	330	467	224	3.73
80	450	619	220	3.67
100	570	740	214	3.57

Force Table (Use for Airstroke™ actuator design)						
Assembly Height (in.)	Volume @ 100 PSIG (in <sup>3</sup> )	Pounds Force				
		@20 PSIG	@40 PSIG	@60 PSIG	@80 PSIG	@100 PSIG
2.0	6	110	230	340	460	580

Description		Assembly Order No.
Style 1M1A-1	Blind nut, 1/8 NPT, brass stud	W02-358-3003
Two Ply Bellows		
Assembly weight .....		0.5 lbs.
Force to collapse to minimum height (@ 0 PSIG) .....		20 lbs.

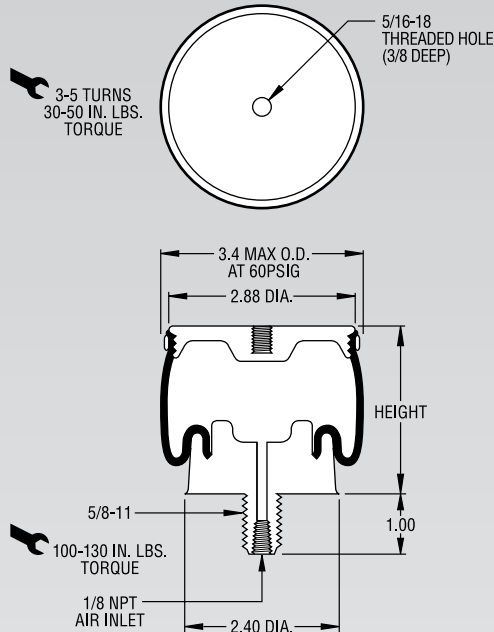

**NOTE:** The dotted line on the static data chart shows the force capabilities of the 1M1A-1 when attaching an additional 0.5 inch pedestal, provided by the customer, to the base of the air spring. If an additional pedestal is not used, the air spring will behave as the solid line depicts. Without a pedestal the rubber part will contact the ground at the height of 2.1 inches and could cause the rubber part to wear prematurely.

**NOTE:** Threads are not flush to piston face.

Dynamic Characteristics at 3.0 in. Design Height (Required for Airmount isolator design only)				
Volume @ 100 PSIG = 14 in <sup>3</sup>			Natural Frequency	
Gage Pressure (PSIG)	Load (lbs.)	Spring Rate (lbs./in.)	CPM	HZ
40	235	191	199.52	3.33
60	356	274	169.93	2.83
80	475	352	161.74	2.70
100	593	458	165.29	2.75

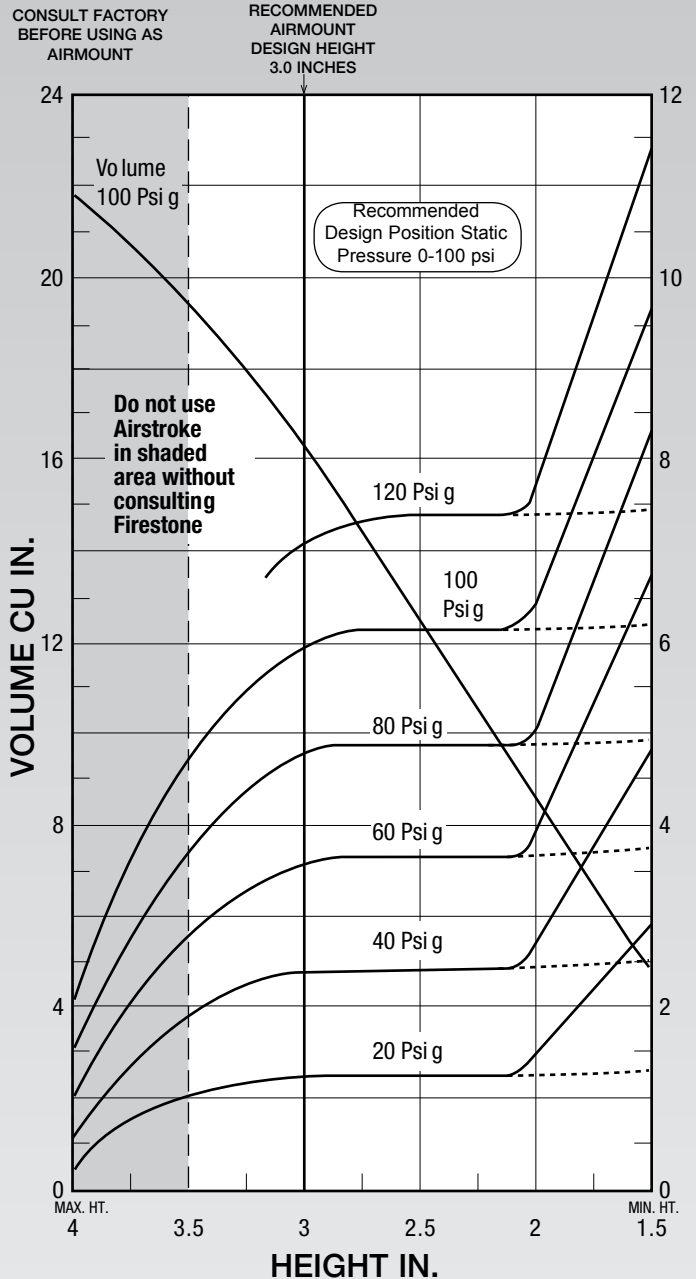

See page 12 for instructions on how to use chart.

Force Table (Use for Airstroke™ actuator design)						
Assembly Height (in.)	Volume @ 100 PSIG (in <sup>3</sup> )	Pounds Force				
		@20 PSIG	@40 PSIG	@60 PSIG	@80 PSIG	@100 PSIG
3.0	14	118	235	356	475	593

## AIRSTROKE ACTUATOR ONLY

Recommended  
Design Position Static  
Pressure 0-100 psi

Description		Assembly Order No.
Style 2M1A	1/8 NPT, each end, plastic studs	W02-358-3002
Two Ply Bellows	1/8 NPT, each end brass studs	W02-358-3004
Assembly weight .....		0.6 lbs.
Force to collapse to minimum height (@ 0 PSIG)...		30 lbs.

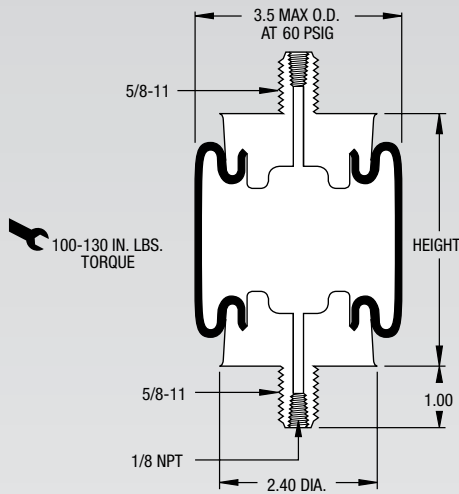
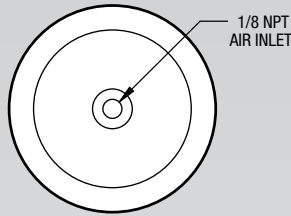

**NOTE:** This Airstroke actuator must be guided throughout the stroke.

**NOTE:** Do not use as an Airmount isolator.

**NOTE:** Plug off one end. (This part is single acting)

**NOTE:**  
**Do not use as an Airmount isolator.**

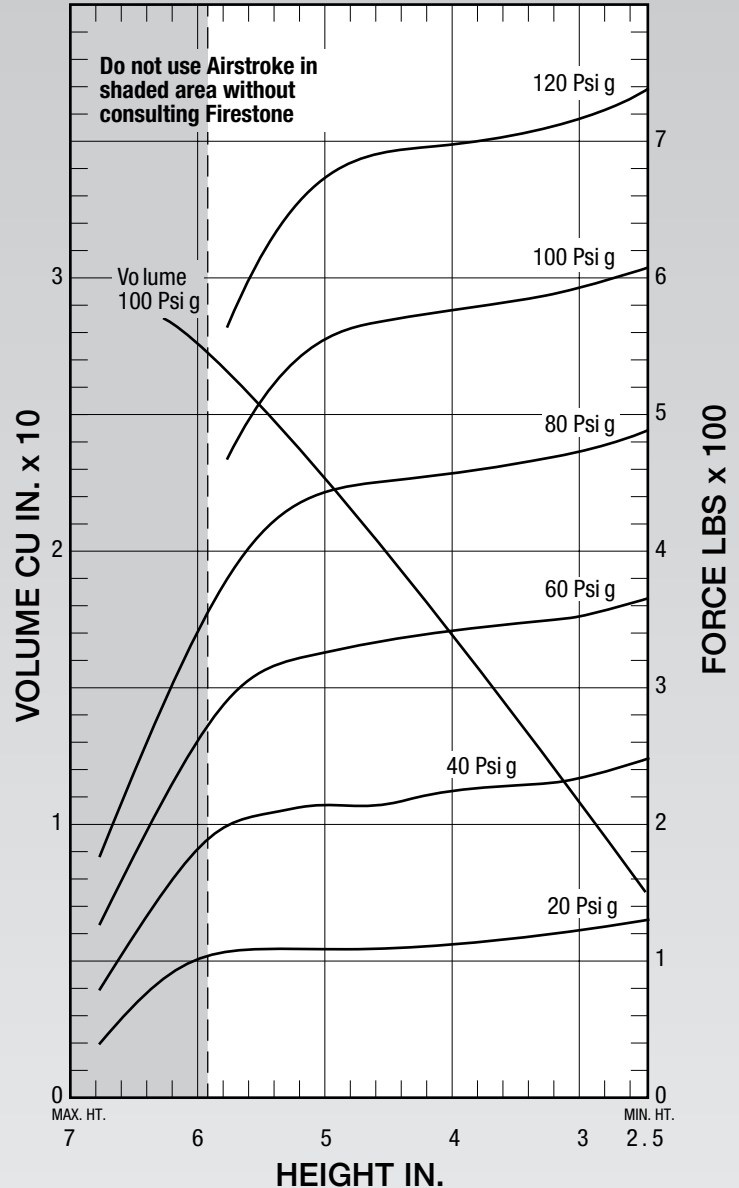

See page 12 for instructions on how to use chart.

**Force Table (Use for Airstroke™ actuator design)**

Assembly Height (in.)	Volume @ 100 PSIG (in <sup>3</sup> )	Pounds Force				
		@20 PSIG	@40 PSIG	@60 PSIG	@80 PSIG	@100 PSIG
6.0	28	100	180	270	350	430
5.0	23	110	210	330	440	560
4.0	17	120	230	340	460	580
3.0	11	120	240	350	480	600



Description		Assembly Order No.
Style 2M2A	Blind nut, 1/8 NPT, plastic studs	W02-358-3008
Two Ply Bellows		
Assembly weight.....		0.15 lbs.
Force to collapse to minimum height (@ 0 PSIG)...		5 lbs.

Recommended Design Position Static Pressure 0-100 psi

RECOMMENDED AIRMOUNT DESIGN HEIGHT 1.8 INCHES

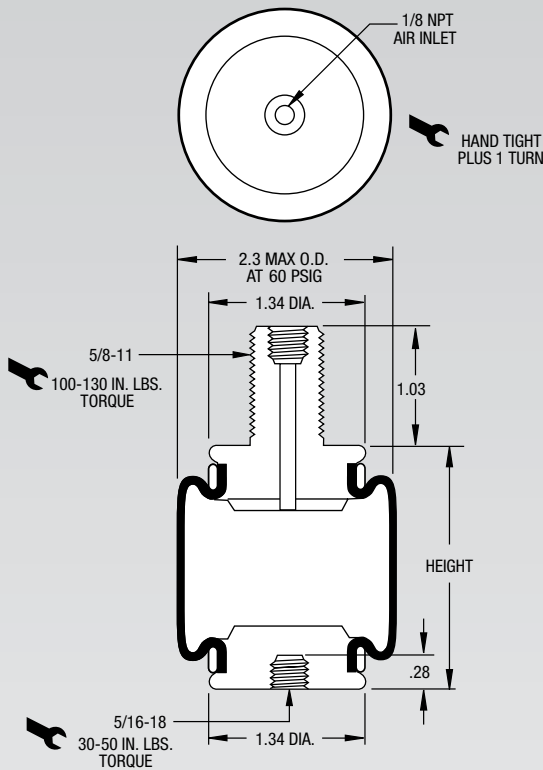

**NOTE:** This Airstroke actuator must be guided throughout the stroke.

**NOTE:** The 2M2A is laterally unstable when used unsupported as an isolator. Contact Firestone for use in isolation applications.

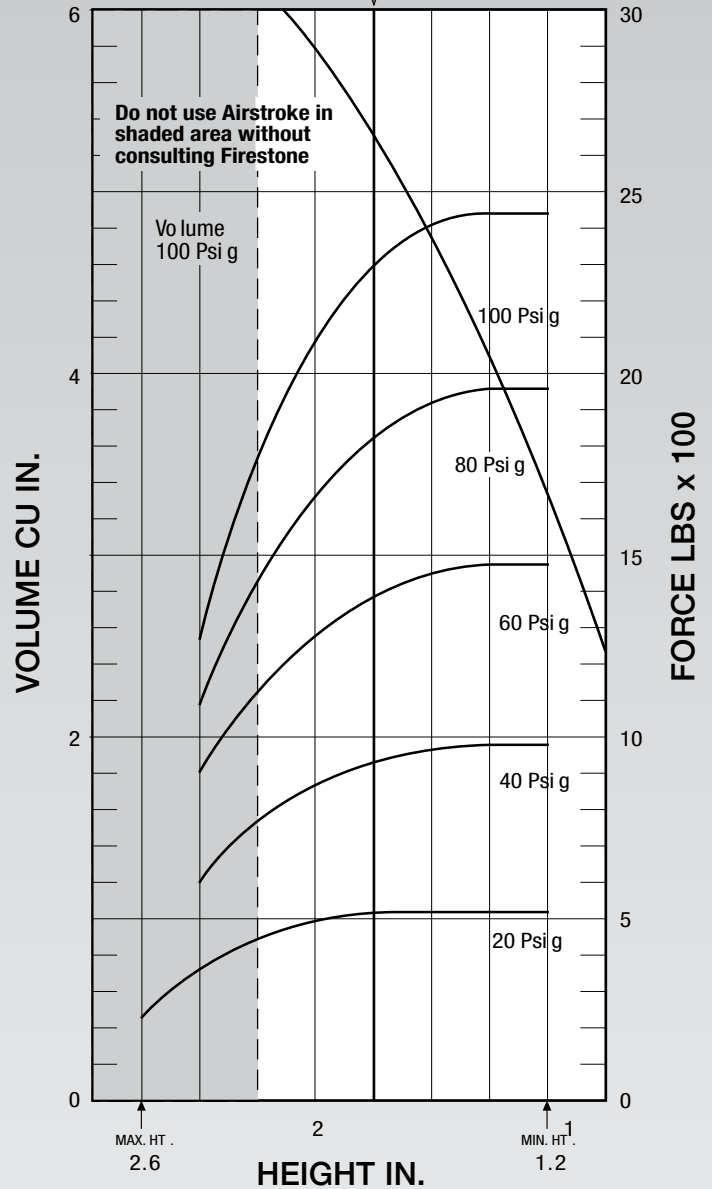

See page 12 for instructions on how to use chart.

Dynamic Characteristics at 1.8 in. Design Height (Required for Airmount isolator design only)				
Volume @ 100 PSIG = 4.39 in <sup>3</sup>			Natural Frequency	
Gage Pressure (PSIG)	Load (lbs.)	Spring Rate (lbs./in.)	CPM	HZ
40	95	122	213	3.55
60	140	175	210	3.51
80	184	230	210	3.51
100	228	289	211	3.53

Force Table (Use for Airstroke™ actuator design)						
Assembly Height (in.)	Volume @ 100 PSIG (in <sup>3</sup> )	Pounds Force				
		@20 PSIG	@40 PSIG	@60 PSIG	@80 PSIG	@100 PSIG
2.2	5.37	40	76	110	140	160
2.0	4.88	44	88	127	167	205
1.8	4.39	52	95	140	184	228
1.6	3.90	52	97	144	192	240
1.4	3.42	52	99	148	196	242
1.2	2.93	52	98	148	196	242

Description		Assembly Order No.
Style 16	Blind nuts, 1/4 NPT	W01-358-7001
	Blind nuts, 3/4 NPT	W01-358-6996
Two Ply Bellows	Socket head aluminum bead rings (bolts, nuts, washers not included-use 1/4 cap screws)	W01-358-0017
	3/4 NPT (only) upper plate, blind nuts lower plate	W01-358-0286
	Rubber bellows only	W01-358-0010
Assembly weight .....		2.5 lbs.
Force to collapse to minimum height (@ 0 PSIG)...		30 lbs.

Recommended Design Position Static Pressure 0-100 psi

RECOMMENDED AIRMOUNT DESIGN HEIGHT 3.0 INCHES

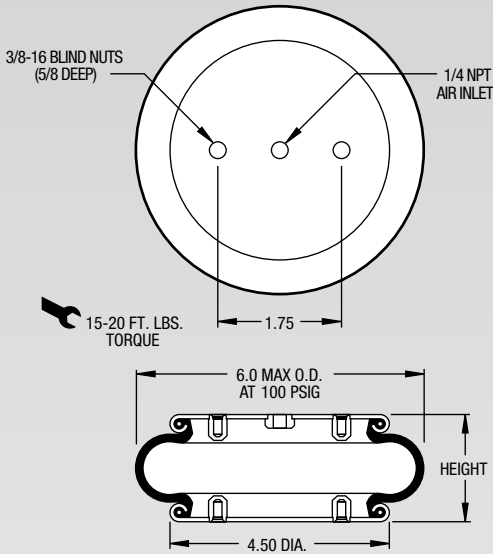

**NOTE:** A bead plate part is shown. This part is also available with bead rings. Bolts are not included. See pages 8-10 for explanation.

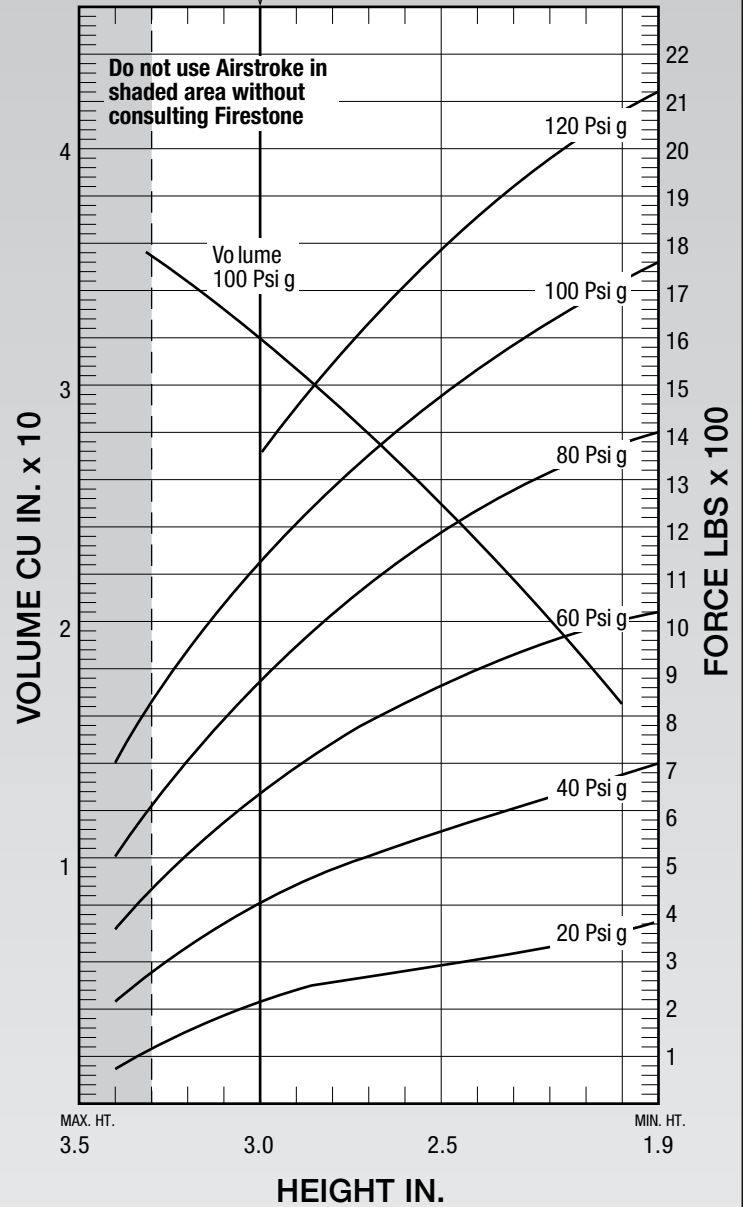

See page 12 for instructions on how to use chart.

Volume @ 100 PSIG = 32 in <sup>3</sup>			Natural Frequency	
Gage Pressure (PSIG)	Load (lbs.)	Spring Rate (lbs./in.)	CPM	HZ
40	420	765	254	4.24
60	640	1,088	244	4.07
80	880	1,410	237	3.96
100	1,120	1,710	232	3.86

Assembly Height (in.)	Volume @ 100 PSIG (in <sup>3</sup> )	Pounds Force				
		@20 PSIG	@40 PSIG	@60 PSIG	@80 PSIG	@100 PSIG
3.0	32	220	420	640	880	1,120
2.0	17	350	680	1,020	1,370	1,720

Description		Assembly Order No.
Style 131	Blind nuts, 1/4 NPT	W01-358-7731
	Blind nuts, 3/4 NPT	W01-358-7742
Two Ply Bellows	Socket head aluminum bead rings (bolts, nuts, washers not included-use 1/4 cap screws)	W01-358-0127
	<del>3/4 NPT (only) upper plate, blind nuts lower plate</del>	<del>W01-358-7729</del>
	Rubber bellows only	W01-358-0131
Assembly weight .....		2.8 lbs.
Force to collapse to minimum height (@ 0 PSIG)...		32 lbs.

Recommended Design Position Static Pressure 0-100 psi

RECOMMENDED AIRMOUNT DESIGN HEIGHT 3.5 INCHES

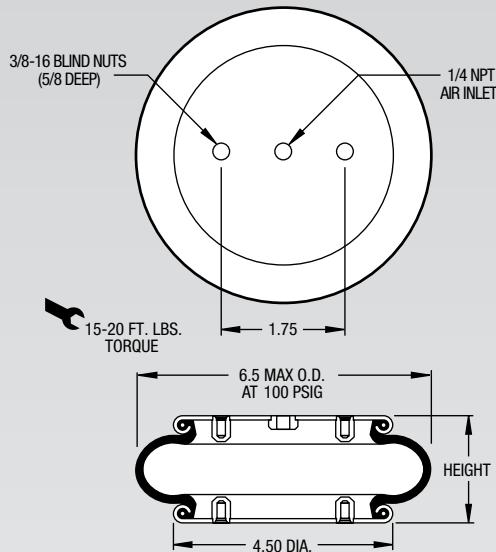

**NOTE: A bead plate part is shown. This part is also available with bead rings. Bolts are not included. See pages 8-10 for explanation.**

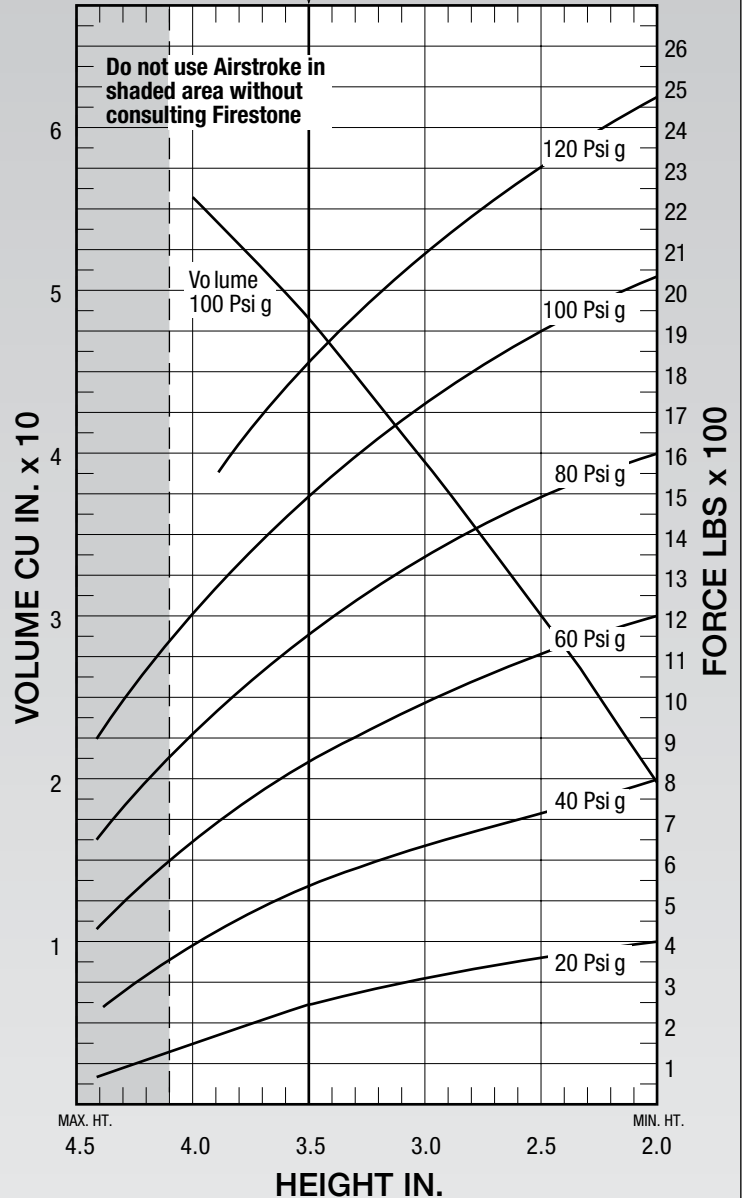

See page 12 for instructions on how to use chart.

Dynamic Characteristics at 3.5 in. Design Height (Required for Airmount isolator design only)				
Volume @ 100 PSIG = 53 in <sup>3</sup>			Natural Frequency	
Gage Pressure (PSIG)	Load (lbs.)	Spring Rate (lbs./in.)	CPM	HZ
40	550	587	195	3.25
60	850	833	186	3.09
80	1,170	1,082	181	3.01
100	1,510	1,331	176	2.94

Force Table (Use for Airstroke™ actuator design)						
Assembly Height (in.)	Volume @ 100 PSIG (in <sup>3</sup> )	Pounds Force				
		@20 PSIG	@40 PSIG	@60 PSIG	@80 PSIG	@100 PSIG
4.0	56	160	400	650	910	1,210
3.0	39	310	640	990	1,350	1,730
2.0	20	390	790	1,200	1,600	2,050

Description		Order No.
Style 160	Blind nuts, 1/4 NPT	W01-358-7751
	Blind nuts, 3/4 NPT	W01-358-7752
Two Ply Bellows	Socket head aluminum bead rings (bolts, nuts, washers not included-use 1/4 cap screws)	W01-358-7592
Assembly weight .....		3.0 lbs.
Force to collapse to minimum height (@ 0PSIG) ...		140 lbs.

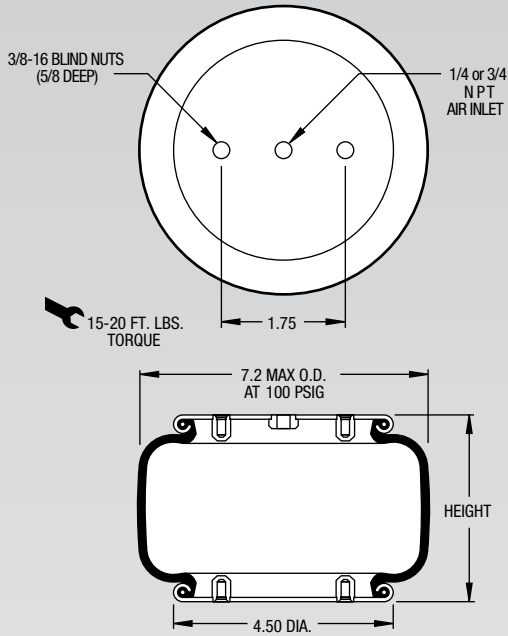

**NOTE:** The dotted line on the static data chart shows the force capabilities of the 160 when attaching an additional 0.5" pedestal, provided by the customer, to both ends of the air spring. If an additional pedestal is not used, the air spring will behave as the solid line depicts. Without the pedestal the rubber part will contact the mounting surface at the height of 2.9". This could cause wear prematurely to the rubber part.

**NOTE:** A bead plate part is shown. This part is also available with bead rings. Bolts are not included. See pages 8-10 for explanation.

Recommended Design Position Static Pressure 0-100 psi

RECOMMENDED AIRMOUNT DESIGN HEIGHT 5.5 INCHES

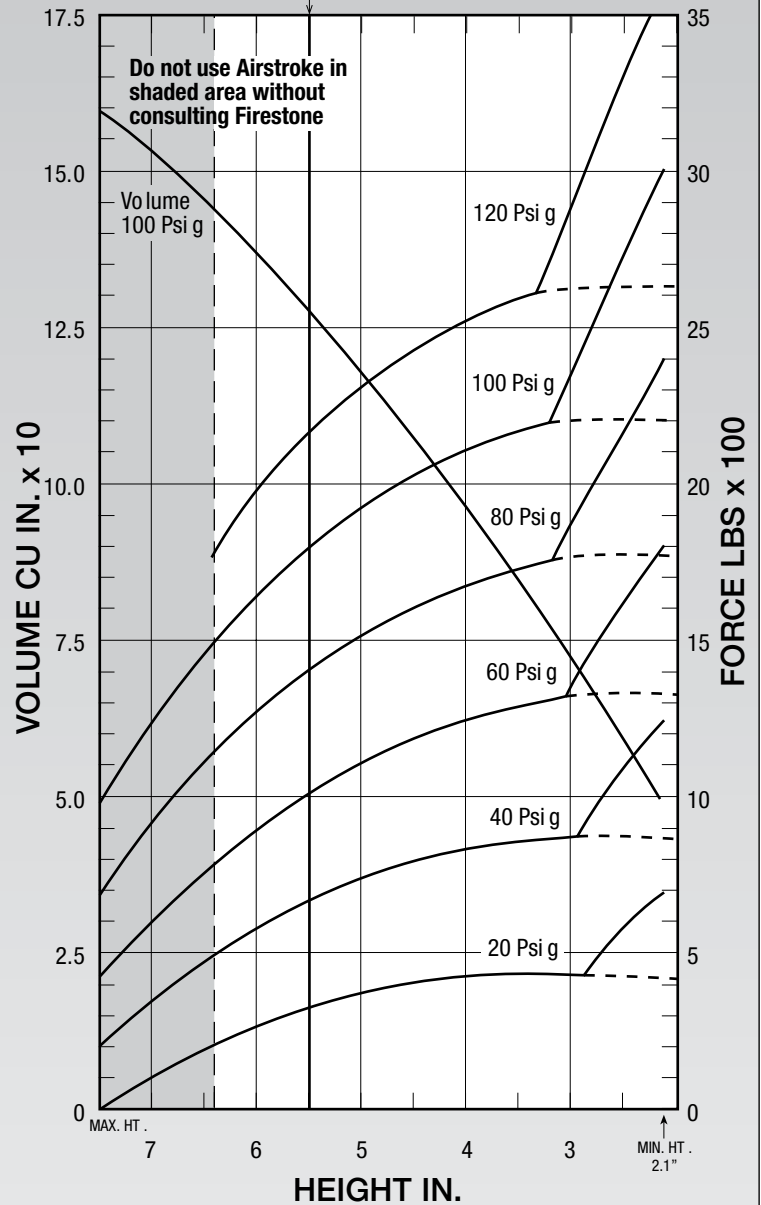

See page 12 for instructions on how to use chart.

Dynamic Characteristics at 5.5 in. Design Heights (Required for Airmount isolator design only)				
Volume @ 100 PSIG = 128 in <sup>3</sup>			Natural Frequency	
Gage Pressure (PSIG)	Load (lbs.)	Spring Rate (lbs./in.)	CPM	HZ
40	650	327	133	2.22
60	1010	464	127	2.12
80	1390	601	124	2.07
100	1760	737	121	2.02

Force Table (Use for Airstroke™ actuator design)						
Assembly Height (in.)	Volume @ 100 PSIG (in <sup>3</sup> )	Pounds Force				
		@20 PSIG	@40 PSIG	@60 PSIG	@80 PSIG	@100 PSIG
6	137	240	560	900	1250	1620
5	118	340	710	1100	1500	1920
4	97	400	810	1240	1670	2110
3	73	440	870	1360	1870	2390

Description		Assembly Order No.
Style 110	Blind nuts, 1/4 NPT	W01-358-7451
	Blind nuts, 3/4 NPT	W01-358-7484
Two Ply Bellows	Socket head aluminum bead rings (bolts, nuts, washers not included-use 1/4 cap screws)	W01-358-0112
	Rubber bellows only	W01-358-0100
Assembly weight .....		3.0 lbs.
Force to collapse to minimum height (@ 0 PSIG).....		8 lbs.

Recommended Design Position Static Pressure 0-100 psi

RECOMMENDED AIRMOUNT DESIGN HEIGHT 4.5 INCHES

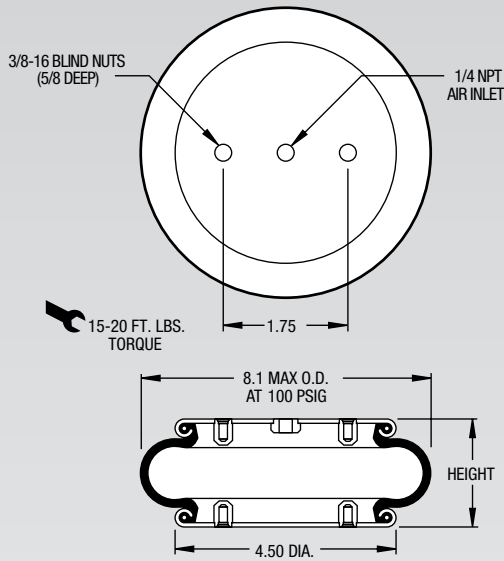

**NOTE: A bead plate part is shown. This part is also available with bead rings. Bolts are not included. See pages 8-10 for explanation.**

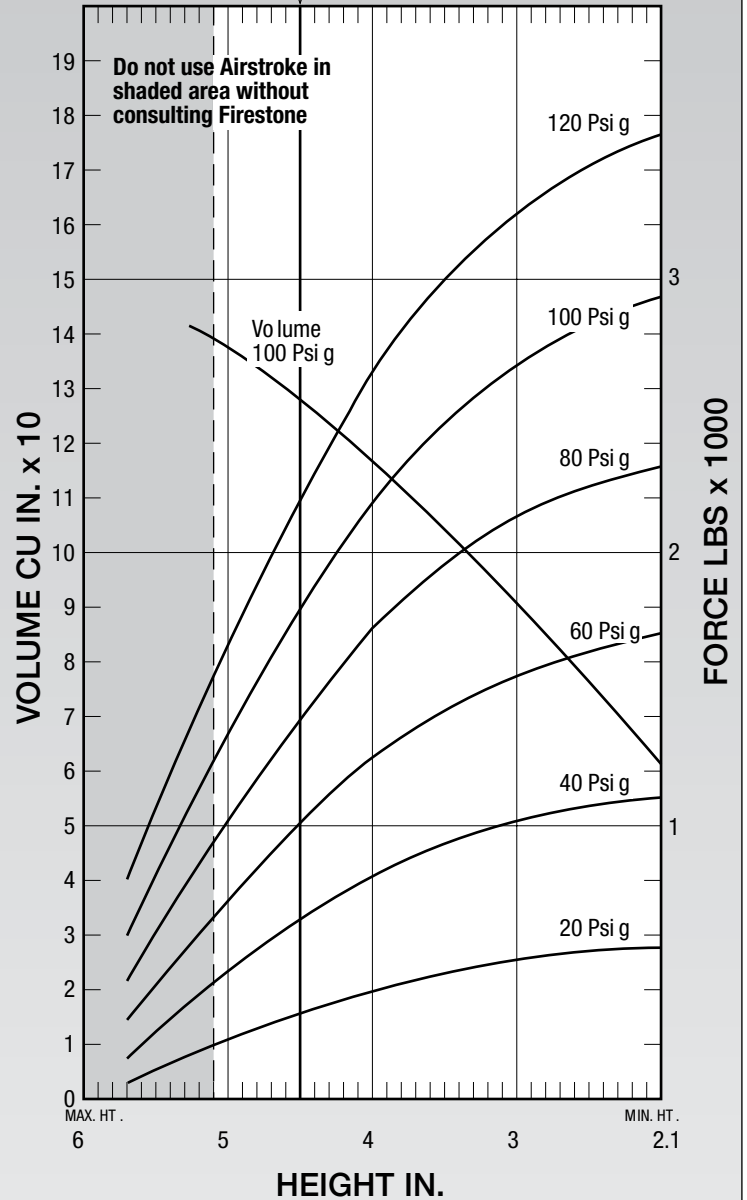

See page 12 for instructions on how to use chart.

Dynamic Characteristics at 4.5 in. Design Height (Required for Airmount isolator design only)				
Volume @ 100 PSIG = 128 in <sup>3</sup>			Natural Frequency	
Gage Pressure (PSIG)	Load (lbs.)	Spring Rate (lbs./in.)	CPM	HZ
40	650	554	173	2.88
60	1,010	795	167	2.77
80	1,390	1,046	162	2.71
100	1,790	1,294	160	2.66

Force Table (Use for Airstroke™ actuator design)						
Assembly Height (in.)	Volume @ 100 PSIG (in <sup>3</sup> )	Pounds Force				
		@20 PSIG	@40 PSIG	@60 PSIG	@80 PSIG	@100 PSIG
4.0	117	390	810	1,240	1,700	2,160
3.0	91	490	1,010	1,540	2,090	2,650

Description		Assembly Order No.
Style 116	Blind nuts, 1/4 NPT	W01-358-7564
	Blind nuts, 3/4 NPT	W01-358-7561
Two Ply Bellows	Countersunk steel bead rings, 1 <sup>3</sup> / <sub>4</sub> bolts, nuts, washers	W01-358-7568
	Blind nuts with installed 1/4 tank valve	W01-A72-7518
	Rubber bellows only	W01-358-0133
Assembly weight .....		4.6 lbs.
Force to collapse to minimum height (@ 0 PSIG).....		8 lbs.
Style 117	Blind nuts, 1/4 NPT	W01-358-7600
	Blind nuts, 3/4 NPT	W01-358-7602
High Strength Bellows	Countersunk steel bead rings, 1 <sup>3</sup> / <sub>4</sub> bolts, nuts, washers	W01-358-7606

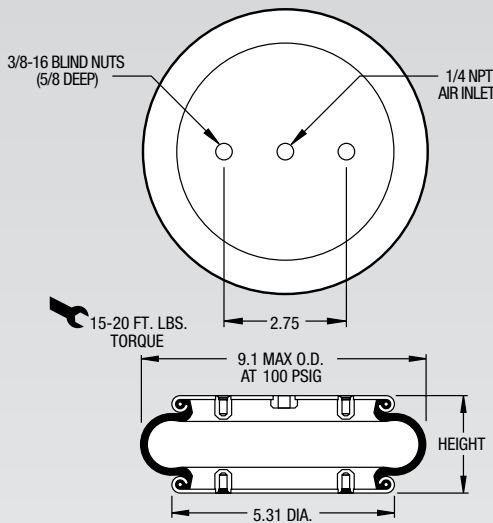

**NOTE:** A bead plate part is shown. This part is also available with bead rings. See pages 8-10 for explanation.

Dynamic Characteristics at 4.5 in. Design Height (Required for Airmount isolator design only)				
Volume @ 100 PSIG = 149 in <sup>3</sup>			Natural Frequency	
Gage Pressure (PSIG)	Load (lbs.)	Spring Rate (lbs./in.)	CPM	HZ
40	850	736	175	2.91
60	1,330	1,070	168	2.80
80	1,830	1,374	163	2.71
100	2,360	1,688	159	2.65

Recommended Design Position Static Pressure 0-100 psi

RECOMMENDED AIRMOUNT DESIGN HEIGHT 4.5 INCHES

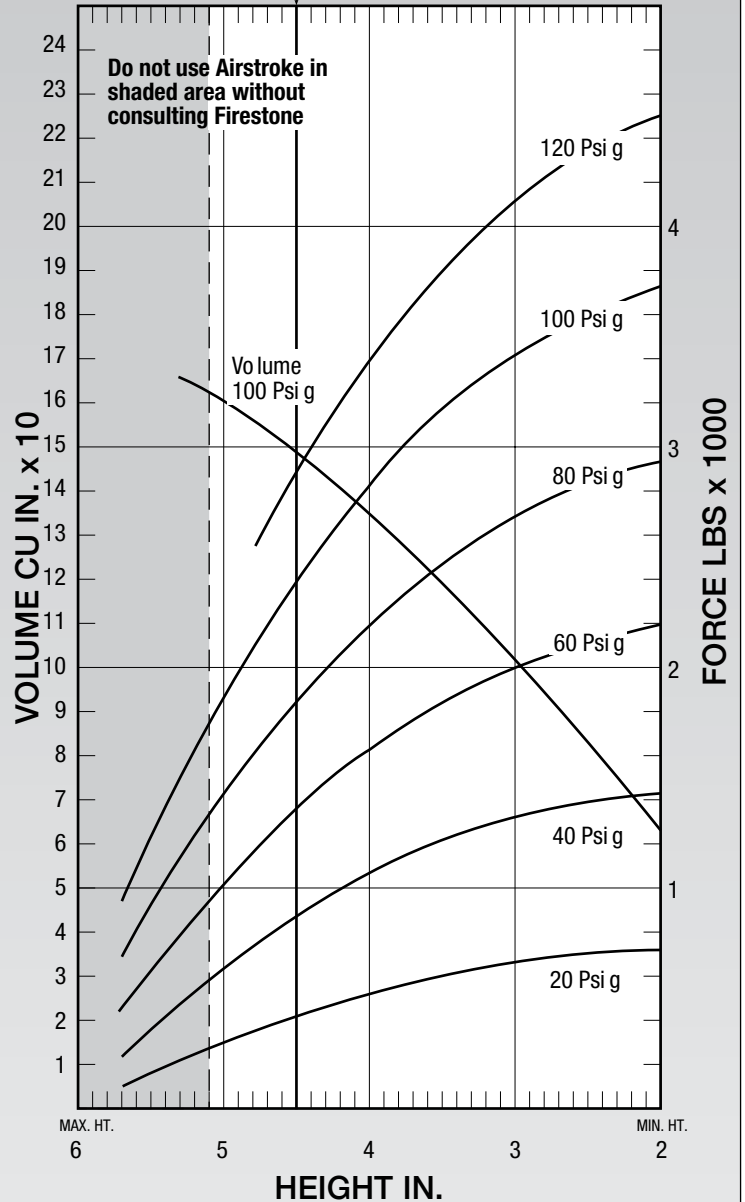

See page 12 for instructions on how to use chart.

Force Table (Use for Airstroke™ actuator design)						
Assembly Height (in.)	Volume @ 100 PSIG (in <sup>3</sup> )	Pounds Force				
		@20 PSIG	@40 PSIG	@60 PSIG	@80 PSIG	@100 PSIG
5.0	161	290	600	970	1,370	1,800
4.0	135	520	1,050	1,630	2,210	2,820
3.0	102	650	1,310	2,000	2,690	3,410

Description		Assembly Order No.
Style 116-1	Blind nuts, 1/4 NPT	W01-358-7598
	Blind nuts, 3/4 NPT	W01-358-7605
Two Ply Bellows		
Assembly weight .....		4.6 lbs.
Force to collapse to minimum height (@ 0 PSIG)...		37 lbs.

Recommended Design Position Static Pressure 0-100 psi

RECOMMENDED AIRMOUNT DESIGN HEIGHT 5.5 INCHES

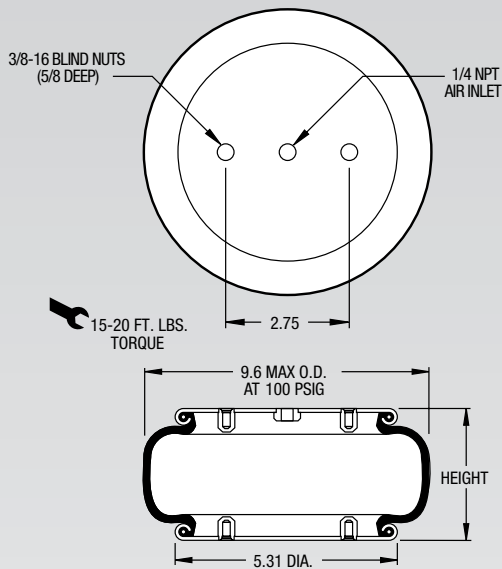

**NOTE:** A bead plate part is shown. This part is also available with bead rings. See pages 8-10 for explanation.

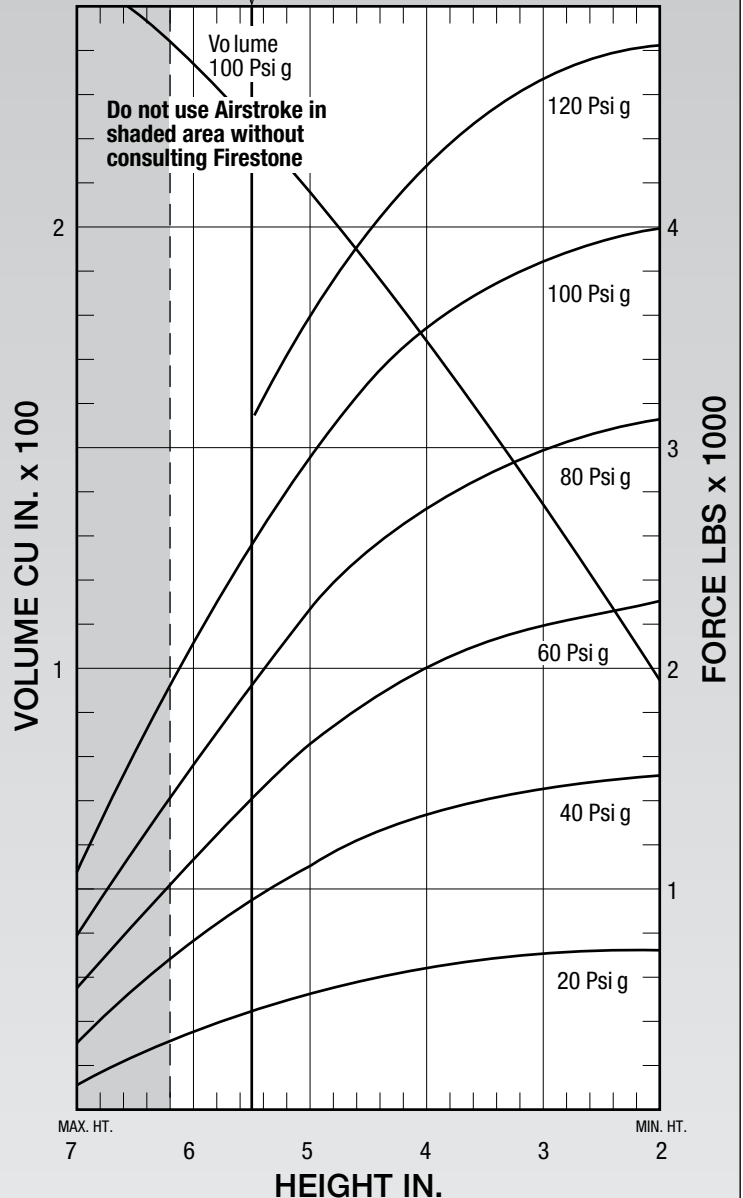

See page 12 for instructions on how to use chart.

Dynamic Characteristics at 5.5 in. Design Height (Required for Airmount isolator design only)				
Volume @ 100 PSIG = 225 in <sup>3</sup>			Natural Frequency	
Gage Pressure (PSIG)	Load (lbs.)	Spring Rate (lbs./in.)	CPM	HZ
40	940	564	145	2.42
60	1,410	803	141	2.36
80	1,930	1,054	139	2.31
100	2,530	1,327	136	2.26

Force Table (Use for Airstroke™ actuator design)						
Assembly Height (in.)	Volume @ 100 PSIG (in <sup>3</sup> )	Pounds Force				
		@20 PSIG	@40 PSIG	@60 PSIG	@80 PSIG	@100 PSIG
6.0	237	360	750	1,150	1,580	2,090
5.0	210	540	1,100	1,650	2,240	2,920
4.0	178	650	1,330	2,000	2,710	3,490
3.0	139	710	1,450	2,200	2,980	3,810

Description		Assembly Order No.
Style 115	Blind nuts, 1/4 NPT	W01-358-7460
	Blind nuts, 1/4 NPT rubber bumper	W01-358-7459
Two Ply Bellows	Blind nuts, 3/4 NPT	W01-358-7465
	Blind nuts, 3/4 NPT rubber bumper	W01-358-7458
	Countersunk steel bead rings, 1 5/8 bolts, nuts, washers	W01-358-7469
	Blind nuts, 3/4 NPT both ends (centered)	W01-606-7115
Rubber bellows only		W01-358-0118
Assembly weight .....		5.7 lbs.
Force to collapse to minimum height (@ 0 PSIG).....		8 lbs.
Style 124	Blind nuts, 1/4 NPT	W01-358-7650
	Blind nuts, 3/4 NPT	W01-358-7649
High Strength Bellows		

Recommended Design Position Static Pressure 0-100 psi

RECOMMENDED AIRMOUNT DESIGN HEIGHT 4.5 INCHES

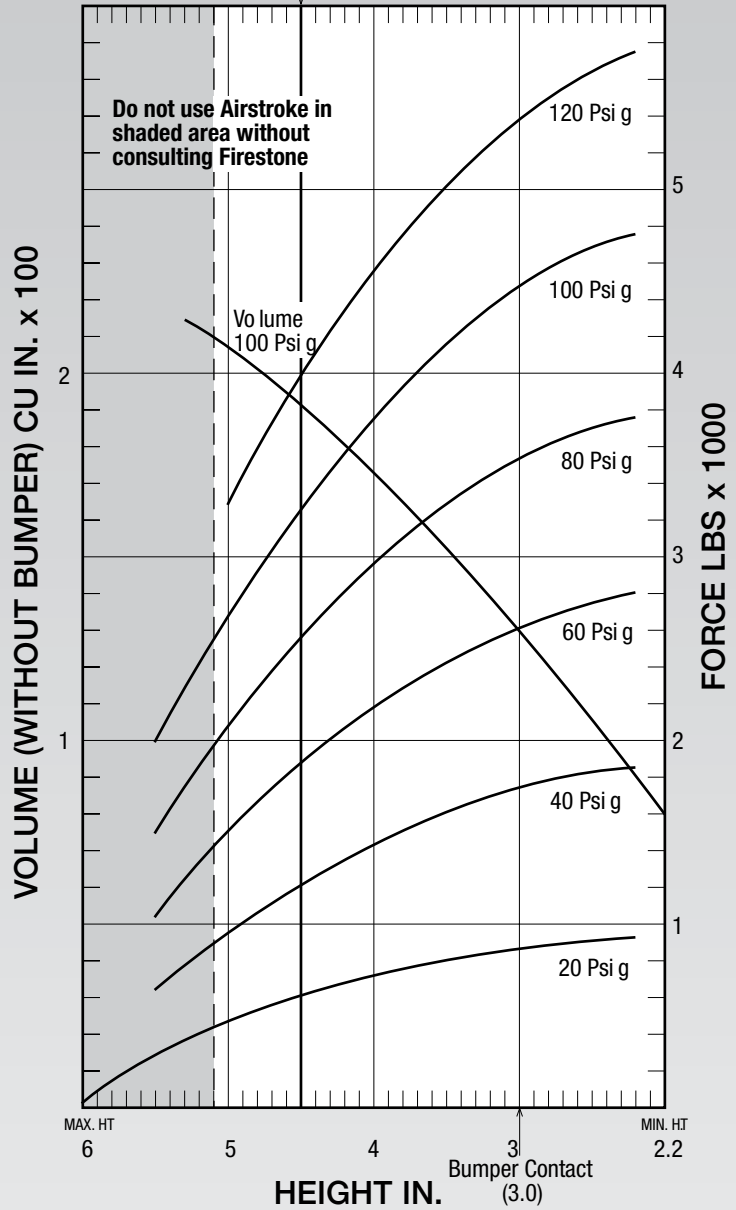

See page 12 for instructions on how to use chart.

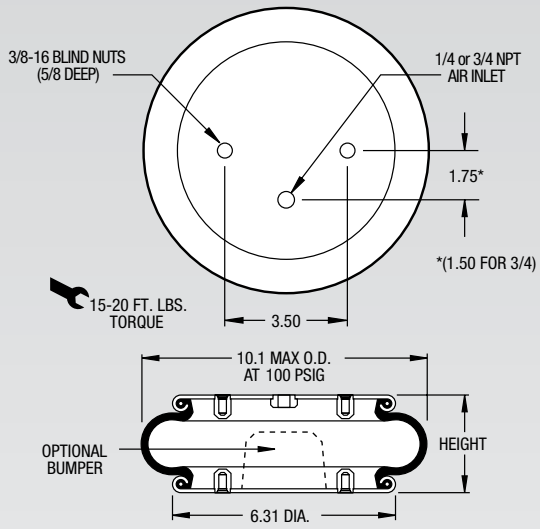

**NOTE: A bead plate part is shown. This part is also available with bead rings. See pages 8-10 for explanation.**

Dynamic Characteristics at 4.5 in. Design Height (Required for Airmount isolator design only)				
Volume @ 100 PSIG = 192 in <sup>3</sup>			Natural Frequency	
Gage Pressure (PSIG)	Load (lbs.)	Spring Rate (lbs./in.)	CPM	HZ
40	1,210	900	162	2.70
60	1,880	1,264	154	2.57
80	2,540	1,638	151	2.52
100	3,270	2,027	148	2.47

Force Table (Use for Airstroke™ actuator design)						
Assembly Height (in.)	Volume @ 100 PSIG (in <sup>3</sup> )	Pounds Force				
		@20 PSIG	@40 PSIG	@60 PSIG	@80 PSIG	@100 PSIG
5.0	209	470	960	1,520	2,080	2,690
4.0	174	700	1,430	2,180	2,940	3,750
3.0	130	820	1,720	2,630	3,510	4,440



Description		Assembly Order No.
Style 19	Blind nuts, 1/4 NPT	W01-358-7008
	Blind nuts, 1/4 NPT, bumper	W01-358-7009
Two Ply Bellows	Blind nuts, 3/4 NPT	W01-358-7011
	Blind nuts, 3/4 NPT, bumper	W01-358-7012
	Countersunk steel bead rings, 1 <sup>5</sup> / <sub>8</sub> bolts, nuts, washers	W01-358-7023
	Rubber bellows only	W01-358-0134
Assembly weight .....		9.6 lbs.
Force to collapse to minimum height (@ 0 PSIG).....		9 lbs.

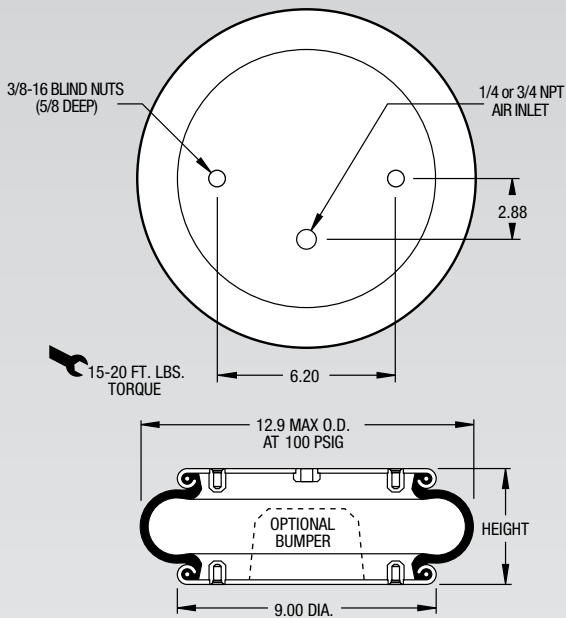

**NOTE: A bead plate part is shown. This part is also available with bead rings. See pages 8-10 for explanation.**

Recommended Design Position Static Pressure 0-100 psi  
RECOMMENDED AIRMOUNT DESIGN HEIGHT 5.0 INCHES

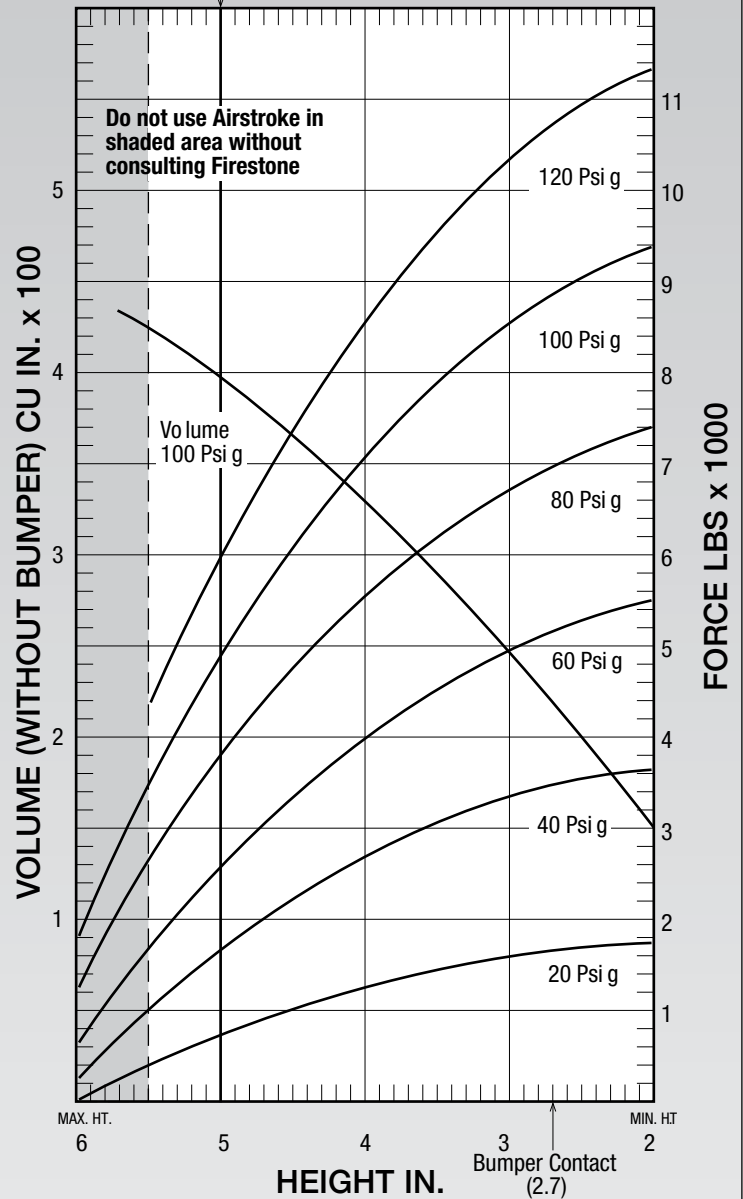

See page 12 for instructions on how to use chart.

Dynamic Characteristics at 5.0 in. Design Height (Required for Airmount isolator design only)				
Volume @ 100 PSIG = 394 in <sup>3</sup>			Natural Frequency	
Gage Pressure (PSIG)	Load (lbs.)	Spring Rate (lbs./in.)	CPM	HZ
40	1,690	1,607	183	3.06
60	2,640	2,322	176	2.93
80	3,730	3,000	168	2.81
100	4,870	3,669	163	2.72

Force Table (Use for Airstroke™ actuator design)						
Assembly Height (in.)	Volume @ 100 PSIG (in <sup>3</sup> )	Pounds Force				
		@20 PSIG	@40 PSIG	@60 PSIG	@80 PSIG	@100 PSIG
5.0	394	780	1,690	2,640	3,730	4,870
4.0	327	1,300	2,610	4,060	5,500	7,050
3.0	244	1,580	3,280	5,000	6,720	8,440

# 19-.75

# Firestone

# AIRSTROKE™ ACTUATORS

# AIRMOUNT™ ISOLATORS

	Description	Assembly Order No.
Style 19-.75	Blind nuts, 1/4 NPT	W01-358-7040
	Blind nuts, 1/4 NPT rubber bumper	W01-358-7039
Two Ply Bellows	Blind nuts, 3/4 NPT	W01-358-7042
	Blind nuts, 3/4 NPT rubber bumper	W01-358-7043
	Counter-sunk steel bead rings, 1 5/8 bolts, nuts, washers	W01-358-6896
Assembly weight .....		9.9 lbs.
Force to collapse to minimum height (@ 0 PSIG)...		15 lbs.

Recommended Design Position Static Pressure 0-100 psi

RECOMMENDED AIRMOUNT DESIGN HEIGHT 5.5 INCHES

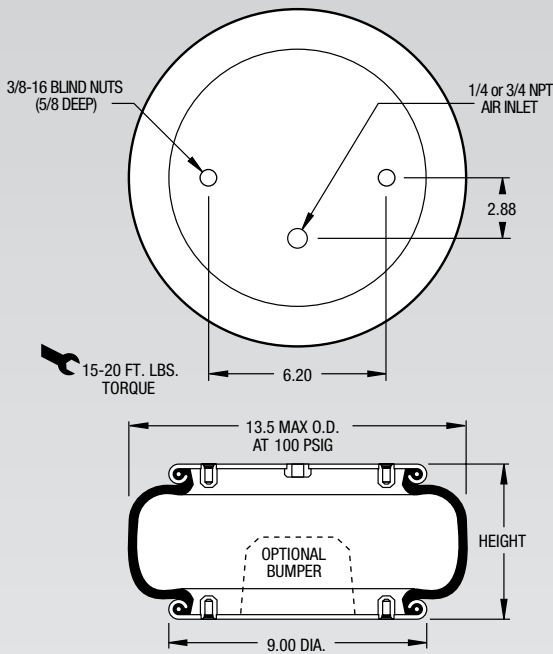

**NOTE:** A bead plate part is shown. This part is also available with bead rings. See pages 8-10 for explanation.

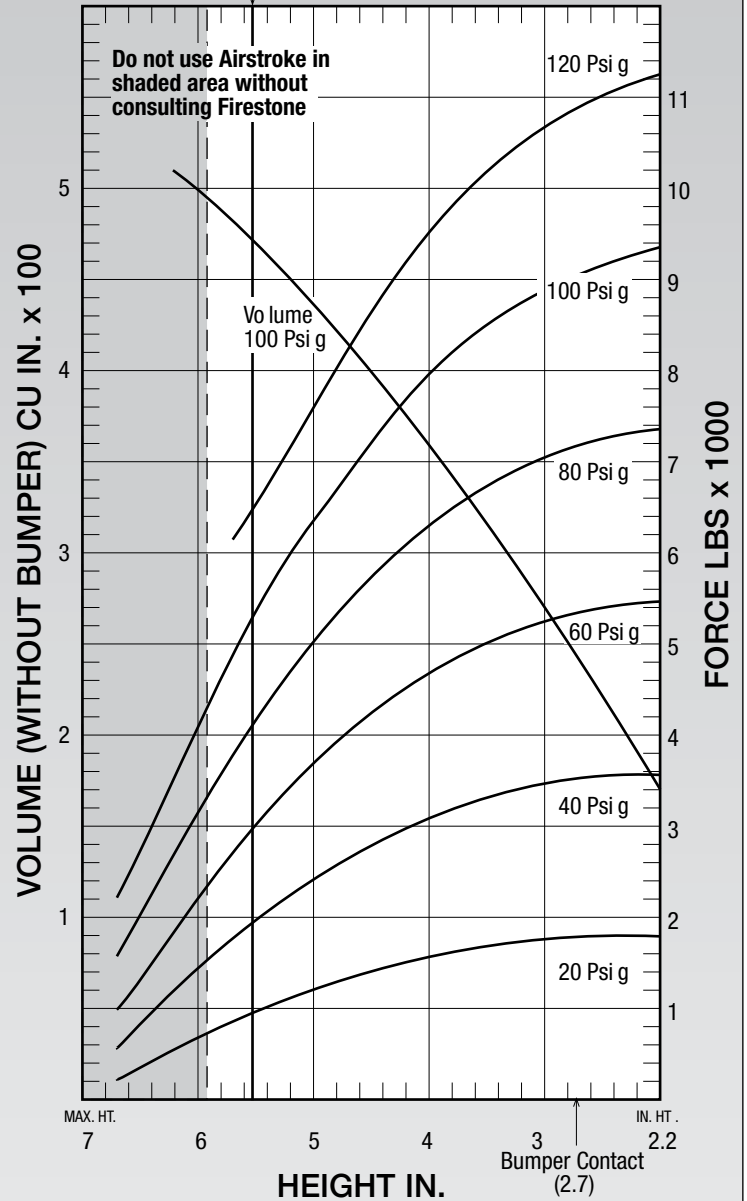

See page 12 for instructions on how to use chart.

Dynamic Characteristics at 5.5 in. Design Height (Required for Airmount isolator design only)				
Volume @ 100 PSIG = 470 in <sup>3</sup>			Natural Frequency	
Gage Pressure (PSIG)	Load (lbs.)	Spring Rate (lbs./in.)	CPM	HZ
40	1,890	1,544	170	2.83
60	2,950	2,203	162	2.70
80	4,080	2,829	156	2.60
100	5,260	3,448	152	2.53

Force Table (Use for Airstroke™ actuator design)						
Assembly Height (in.)	Volume @ 100 PSIG (in <sup>3</sup> )	Pounds Force				
		@20 PSIG	@40 PSIG	@60 PSIG	@80 PSIG	@100 PSIG
5.0	438	1,190	2,390	3,670	5,000	6,360
4.0	359	1,560	3,110	4,710	6,330	7,980
3.0	270	1,730	3,460	5,240	7,040	8,850

Description		Assembly Order No.
Style 113	Blind nuts, 1/4 NPT	W01-358-7103
	Blind nuts, 1/4 NPT, bumper	W01-358-7104
Two Ply Bellows	Blind nuts, 3/4 NPT	W01-358-7101
	Blind nuts, 3/4 NPT, bumper	W01-358-7109
	Countersunk steel bead rings, 1 3/4 bolts, nuts, washers	W01-358-7110
	Blind nuts, 1/8 NPT	W01-753-7113
	Blind nuts, 1 1/4 NPT	W01-753-7114
	Rubber bellows only	W01-358-0135

Assembly weight ..... 14.1 lbs.

Force to collapse to minimum height (@ 0 PSIG)... 17 lbs.

Style 128	Blind nuts, 1/4 NPT	W01-358-8151
	Blind nuts, 1/4 NPT, rubber bumper	W01-358-8149
High Strength Bellows	Blind nuts, 3/4 NPT	W01-358-8152
	Blind nuts, 3/4 NPT, rubber bumper	W01-358-8150
	Rubber bellows only	W01-358-1007

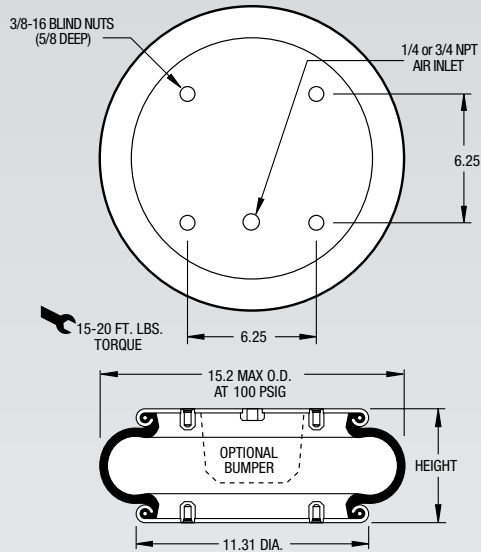

**NOTE:** A bead plate part is shown. This part is also available with bead rings. See pages 8-10 for explanation.

Dynamic Characteristics at 5.0 in. Design Height (Required for Airmount isolator design only)				
Volume @ 100 PSIG = 601 in <sup>3</sup>			Natural Frequency	
Gage Pressure (PSIG)	Load (lbs.)	Spring Rate (lbs./in.)	CPM	HZ
40	3,010	2,322	165	2.75
60	4,610	3,288	158	2.64
80	6,460	4,247	152	2.54
100	8,320	5,176	148	2.47

Recommended Design Position Static Pressure 0-100 psi

RECOMMENDED AIRMOUNT DESIGN HEIGHT 5.0 INCHES

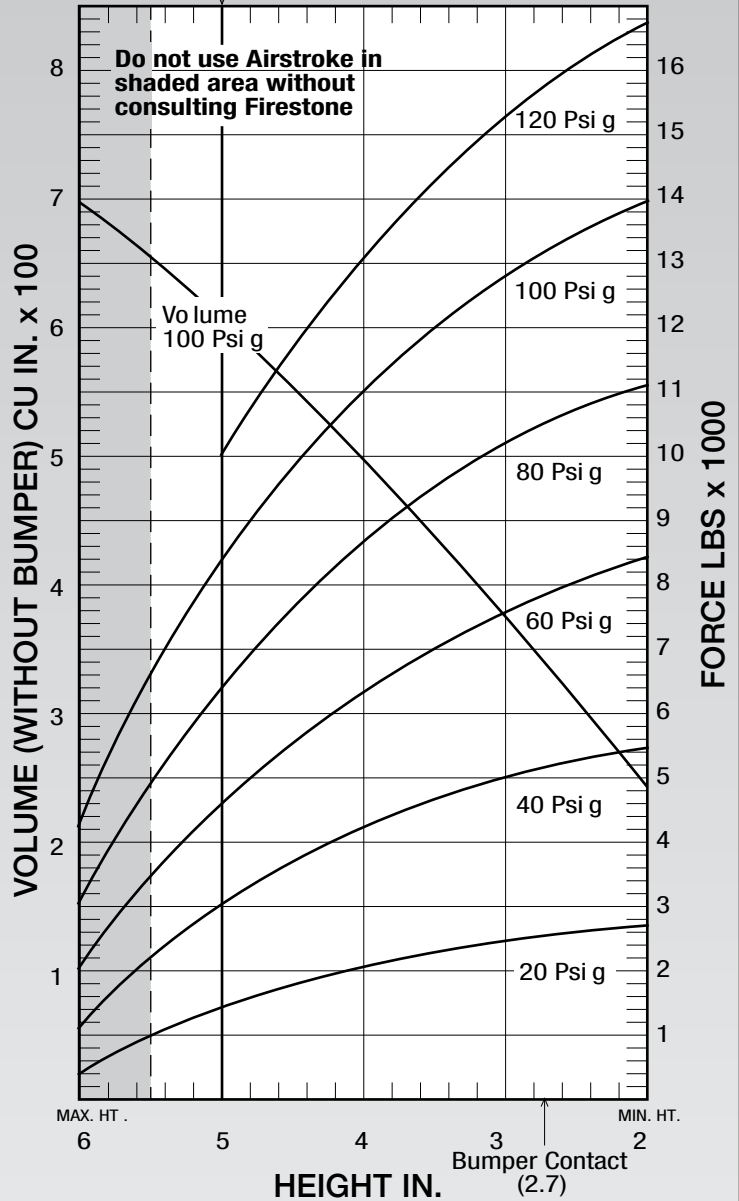

See page 12 for instructions on how to use chart.

Force Table (Use for Airstroke™ actuator design)						
Assembly Height (in.)	Volume @ 100 PSIG (in <sup>3</sup> )	Pounds Force				
		@20 PSIG	@40 PSIG	@60 PSIG	@80 PSIG	@100 PSIG
5.0	601	1,420	3,010	4,610	6,460	8,320
4.0	499	2,030	4,160	6,340	8,640	10,820
3.0	375	2,430	5,000	7,610	10,220	12,820

	Description	Assembly Order No.
Style 113-1 Two Ply Bellows	Blind nuts, 1/4 NPT	W01-358-7091
	Blind nuts, 3/4 NPT	W01-358-7092
	Blind nuts, 3/4 NPT, rubber bumper	W01-358-7094
	Countersunk steel bead rings, 1 3/4 bolts, nuts, washers	W01-358-7277
	Rubber bellows only	W01-358-0150
Assembly weight .....		14.5 lbs.
Force to collapse to minimum height (@ 0 PSIG)...		25 lbs.

Style 128-1 High Strength Bellows	Blind nuts, 3/4 NPT	W01-358-8160
	Blind nuts, 3/4 NPT, rubber bumper	W01-358-8162

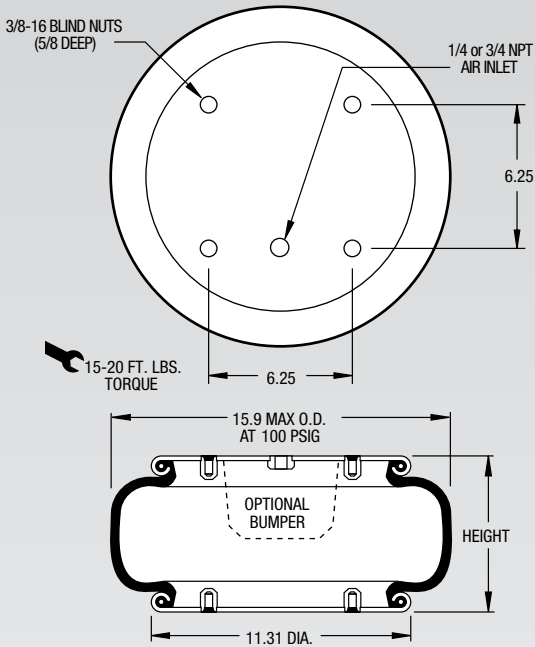

**NOTE:** A bead plate part is shown. This part is also available with bead rings. See pages 8-10 for explanation.

Dynamic Characteristics at 5.5 in. Design Height (Required for Airmount isolator design only)				
Volume @ 100 PSIG = 641 in <sup>3</sup>			Natural Frequency	
Gage Pressure (PSIG)	Load (lbs.)	Spring Rate (lbs./in.)	CPM	HZ
40	3,820	2,198	142	2.37
60	5,900	3,091	136	2.26
80	7,990	3,986	133	2.21
100	10,200	4,923	130	2.17

Recommended Design Position Static Pressure 0-100 psi

RECOMMENDED AIRMOUNT DESIGN HEIGHT 5.5 INCHES

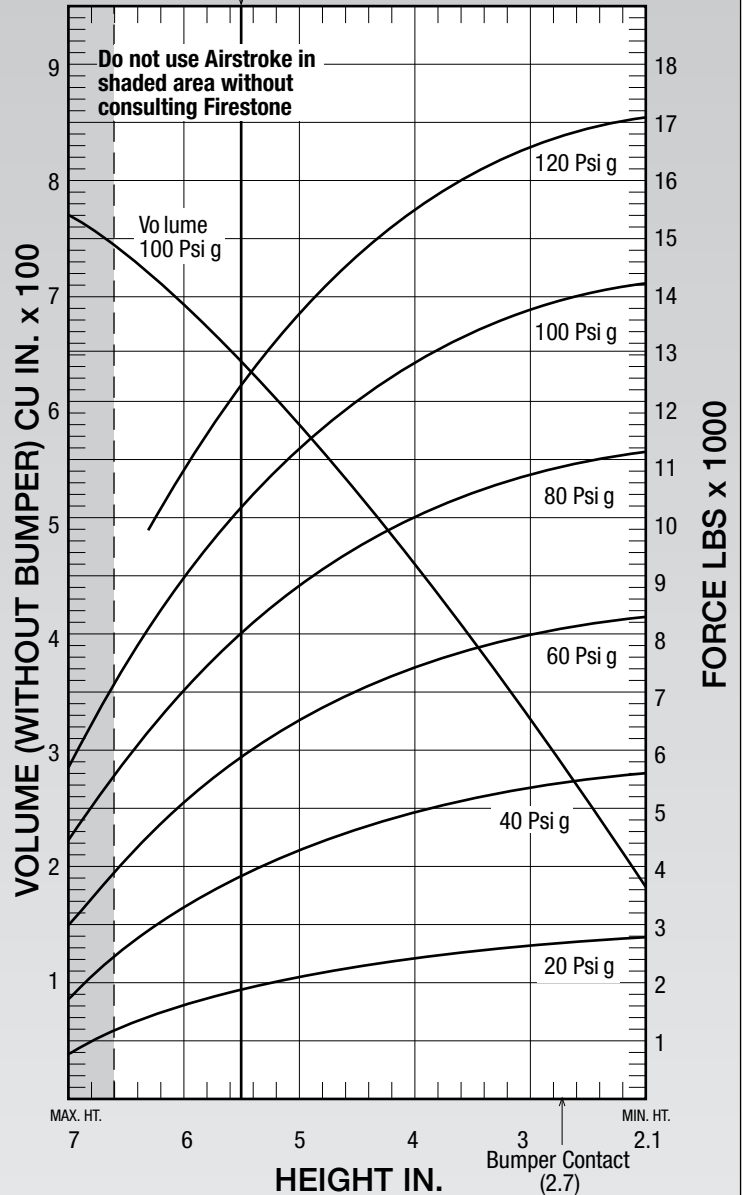

See page 12 for instructions on how to use chart.

Force Table (Use for Airstroke™ actuator design)						
Assembly Height (in.)	Volume @ 100 PSIG (in <sup>3</sup> )	Pounds Force				
		@20 PSIG	@40 PSIG	@60 PSIG	@80 PSIG	@100 PSIG
6.0	692	1,600	3,270	5,130	7,000	8,990
5.0	586	2,070	4,260	6,530	8,800	11,200
4.0	463	2,440	4,940	7,470	10,080	12,710
3.0	328	2,660	5,360	8,060	10,860	13,630

	Description	Assembly Order No.
Style 153-2	Blind nuts, 1/4 NPT	W01-358-8158
Two Ply Bellows	Blind nuts, 3/4 NPT	W01-358-8157
Assembly weight .....		17.1 lbs.

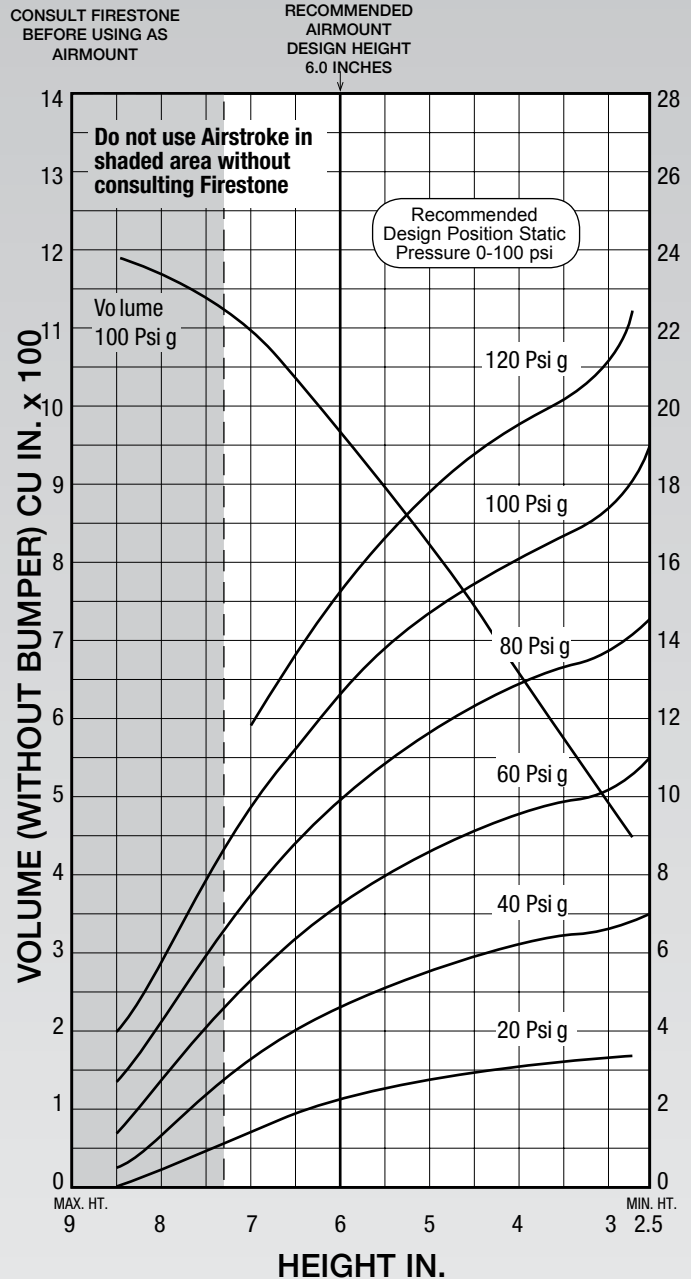
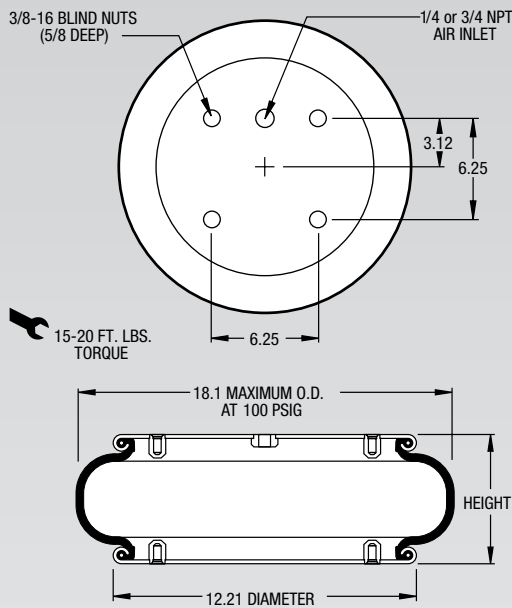

See page 12 for instructions on how to use chart.

Dynamic Characteristics at 6.0 in. Design Height (Required for Airmount isolator design only)				
Volume @ 100 PSIG = 981 in <sup>3</sup>			Natural Frequency	
Gage Pressure (PSIG)	Load (lbs.)	Spring Rate (lbs./in.)	CPM	HZ
40	4,564	2,202	131	2.18
60	7,048	3,153	126	2.10
80	9,682	4,031	121	2.02
100	12,385	4,958	119	1.98

Force Table (Use for Airstroke™ actuator design)						
Assembly Height (in.)	Volume @ 100 PSIG (in <sup>3</sup> )	Pounds Force				
		@20 PSIG	@40 PSIG	@60 PSIG	@80 PSIG	@100 PSIG
8.0	1,169	425	1,260	2,566	4,038	5,636
7.0	1,094	1,423	3,210	5,194	7,334	9,528
6.0	981	2,140	4,564	7,048	9,682	12,385
5.0	840	2,676	5,476	8,458	11,440	14,471
4.0	679	3,051	6,153	9,478	12,738	15,965
3.0	510	3,219	6,609	10,069	13,550	17,218

Description		Assembly Order No.
Style 119	Ribbed neck aluminum bead rings (equal spacing), 1 7/8 bolts, nuts, washers	W01-358-7478
Two Ply Bellows	Rubber bellows only	W01-358-0119
	Rolled Plate Assembly*, 1/2 blind nuts, 3/4 NPT	W01-358-7477
Assembly weight .....		12.1 lbs.
Force to collapse to minimum height (@ 0 PSIG)...		17 lbs.

Recommended Design Position Static Pressure 0-100 psi

RECOMMENDED AIRMOUNT DESIGN HEIGHT 5.0 INCHES

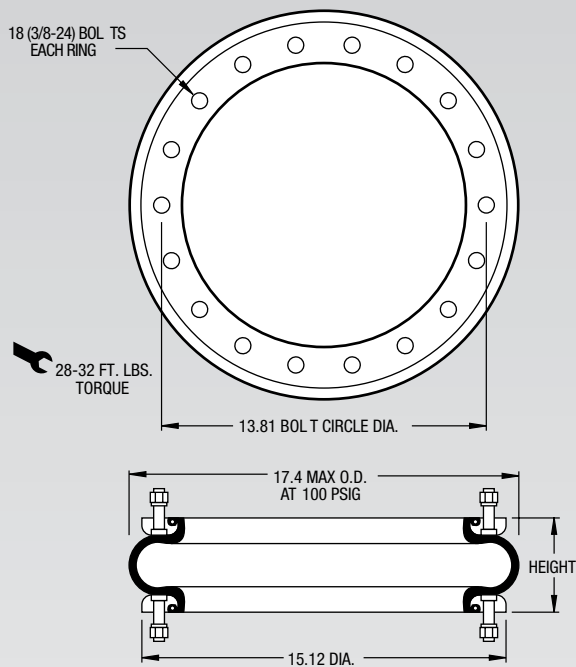

**NOTE:** A bead plate part is shown. This part is also available with rolled plates. See page 11 for explanation.

\*Increase the minimum height by .70 inch. Add .70 inch to the height (bottom axis) before reading loads.

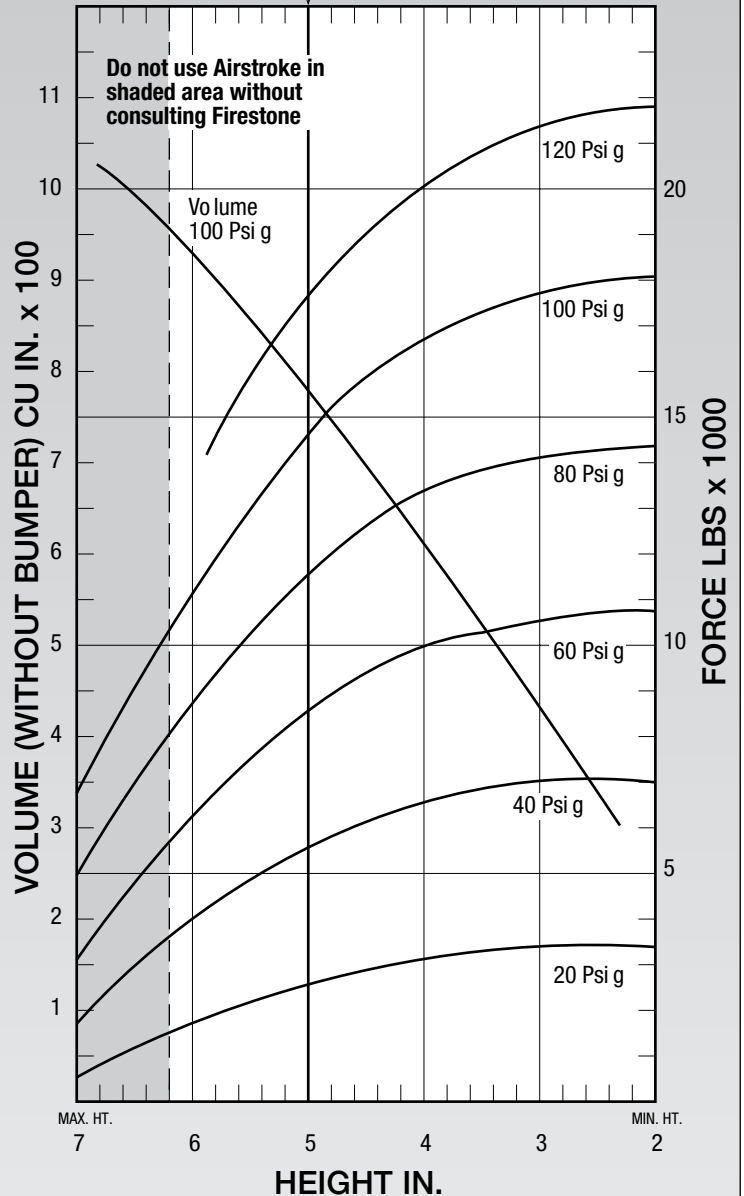

See page 12 for instructions on how to use chart.

Volume @ 100 PSIG = 787 in <sup>3</sup>			Natural Frequency	
Gage Pressure (PSIG)	Load (lbs.)	Spring Rate (lbs./in.)	CPM	HZ
40	5,490	3,478	149	2.49
60	8,450	4,880	143	2.38
80	11,450	6,186	138	2.30
100	14,520	7,523	135	2.25

Assembly Height (in.)	Volume @ 100 PSIG (in <sup>3</sup> )	Pounds Force				
		@20 PSIG	@40 PSIG	@60 PSIG	@80 PSIG	@100 PSIG
6.0	932	1,640	3,800	6,100	8,550	11,070
5.0	787	2,560	5,490	8,450	11,450	14,520
4.0	617	3,080	6,470	9,850	13,190	16,600
3.0	436	3,310	6,920	10,530	14,030	17,630

Description		Assembly Order No.
Style 121	Ribbed neck aluminum bead rings, 1 7/8 bolts, nuts, washers	W01-358-7197
Two Ply Bellows	Rubber bellows only	W01-358-5135
	Rolled Plate Assembly*, 1/2 blind nuts, 3/4 NPT	W01-358-7272
Assembly weight .....		15.3 lbs.
Force to collapse to minimum height (@ 0 PSIG)...		20 lbs.

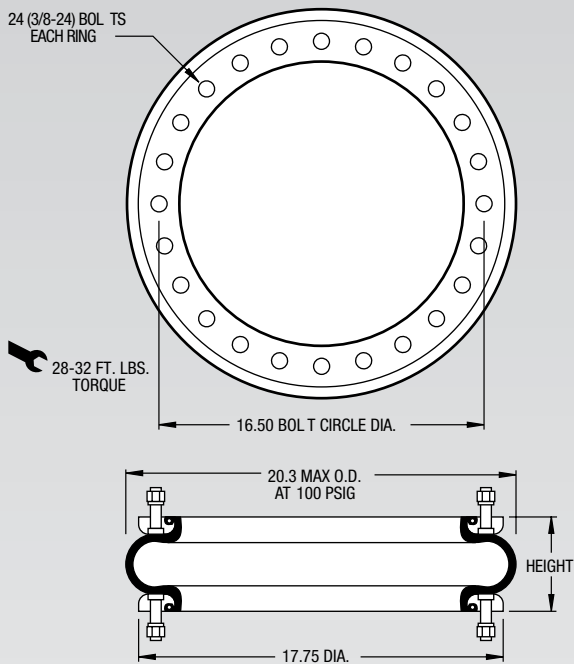

**NOTE: A bead ring part is shown. This part is also available with rolled plates. See page 11 for explanation.**

\*Increase the minimum height by .70 inch. Add .70 inch to the height (bottom axis) before reading loads.

Recommended Design Position Static Pressure 0-100 psi  
RECOMMENDED AIRMOUNT DESIGN HEIGHT 5.0 INCHES

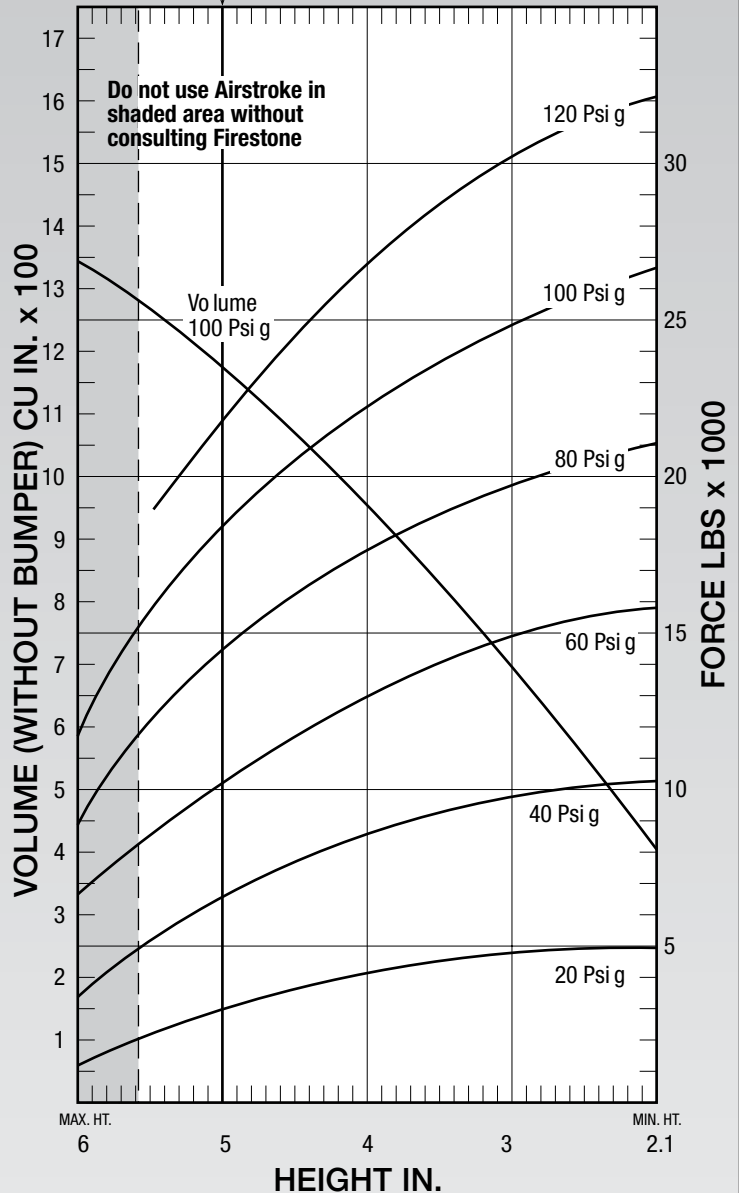

See page 12 for instructions on how to use chart.

Volume @ 100 PSIG = 1,154 in <sup>3</sup>			Natural Frequency	
Gage Pressure (PSIG)	Load (lbs.)	Spring Rate (lbs./in.)	CPM	HZ
40	6,450	4,771	161	2.69
60	10,300	6,441	148	2.47
80	14,450	8,312	142	2.37
100	18,450	10,086	139	2.31

Assembly Height (in.)	Volume @ 100 PSIG (in <sup>3</sup> )	Pounds Force				
		@20 PSIG	@40 PSIG	@60 PSIG	@80 PSIG	@100 PSIG
5.0	1,154	2,830	6,450	10,300	14,450	18,450
4.0	935	4,100	8,540	13,070	17,550	22,180
3.0	682	4,760	9,690	14,750	19,600	24,690

	Description	Assembly Order No.
Style 126	Ribbed neck aluminum bead rings (equal spacing), 1 7/8 bolts, nuts, washers	W01-358-7727
Two Ply Bellows	Rolled Plate Assembly*, 1/2 blind nuts, 3/4 NPT	W01-358-7726
	Rubber bellows only	W01-358-1026
Assembly weight .....		16.6 lbs.
Force to collapse to minimum height (@ 0 PSIG)...		25 lbs.

Recommended Design Position Static Pressure 0-100 psi

RECOMMENDED AIRMOUNT DESIGN HEIGHT 5.0 INCHES

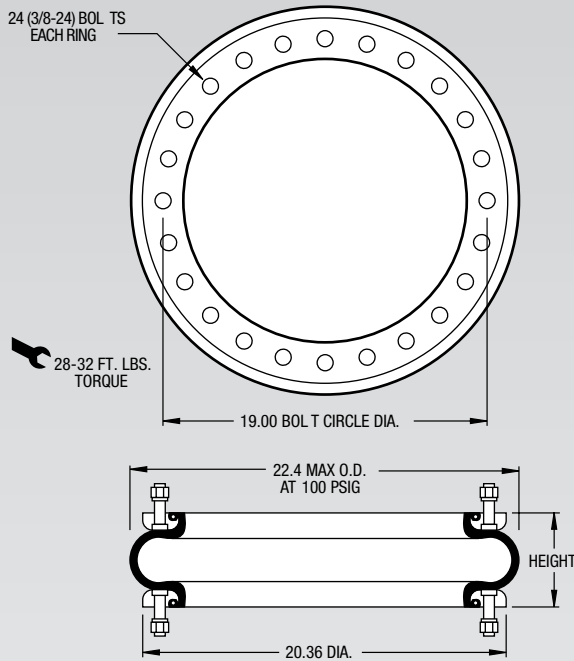

**NOTE:** A bead ring part is shown. This part is also available with rolled plates. See page 11 for explanation.

\*Increase the minimum height by .70 inch. Add .70 inch to the height (bottom axis) before reading loads.

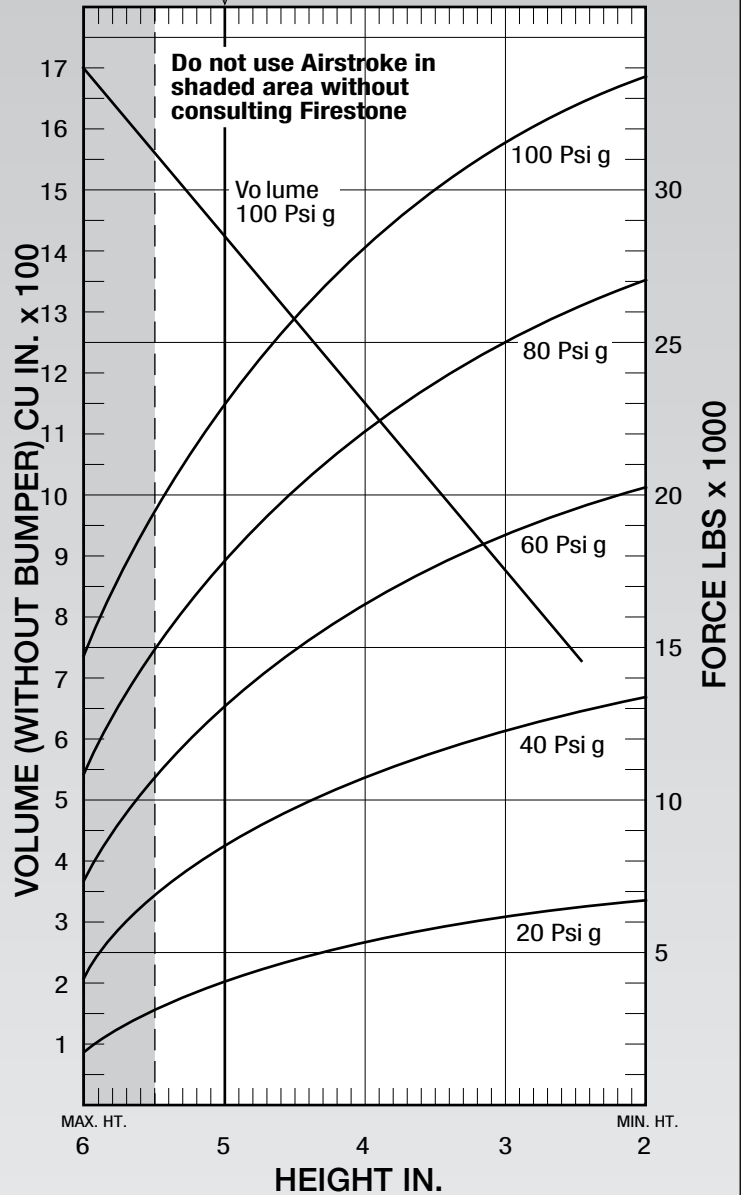

See page 12 for instructions on how to use chart.

Volume @ 100 PSIG = 1,315 in <sup>3</sup>			Natural Frequency	
Gage Pressure (PSIG)	Load (lbs.)	Spring Rate (lbs./in.)	CPM	HZ
40	8,630	5,869	155	2.59
60	13,870	5,244	144	2.42
80	18,450	10,107	139	2.32
100	23,200	12,403	137	2.29

Assembly Height (in.)	Volume @ 100 PSIG (in <sup>3</sup> )	Pounds Force				
		@20 PSIG	@40 PSIG	@60 PSIG	@80 PSIG	@100 PSIG
6.0	1,694	1,800	4,000	7,100	10,900	15,000
5.0	1,473	4,220	8,630	13,870	18,450	23,200
4.0	1,196	5,200	10,840	16,630	22,460	28,070
3.0	875	6,010	12,040	19,020	25,960	32,000



Description		Assembly Order No.
Style 138-1.5	Ribbed neck aluminum bead rings (equal spacing), 1 7/8 bolts, nuts, washers	W01-358-7737
Two Ply High Strength Bellows	Ribbed neck aluminum bead rings (unequal spacing), 1 7/8 bolts, nuts, washers	W01-358-7734
	Rubber bellows only	W01-358-0147
Assembly weight .....		23.8 lbs.
Force to collapse to minimum height (@ 0 PSIG)		150 lbs.

Recommended Design Position Static Pressure 0-100 psi

RECOMMENDED AIRMOUNT DESIGN HEIGHT 6.0 INCHES

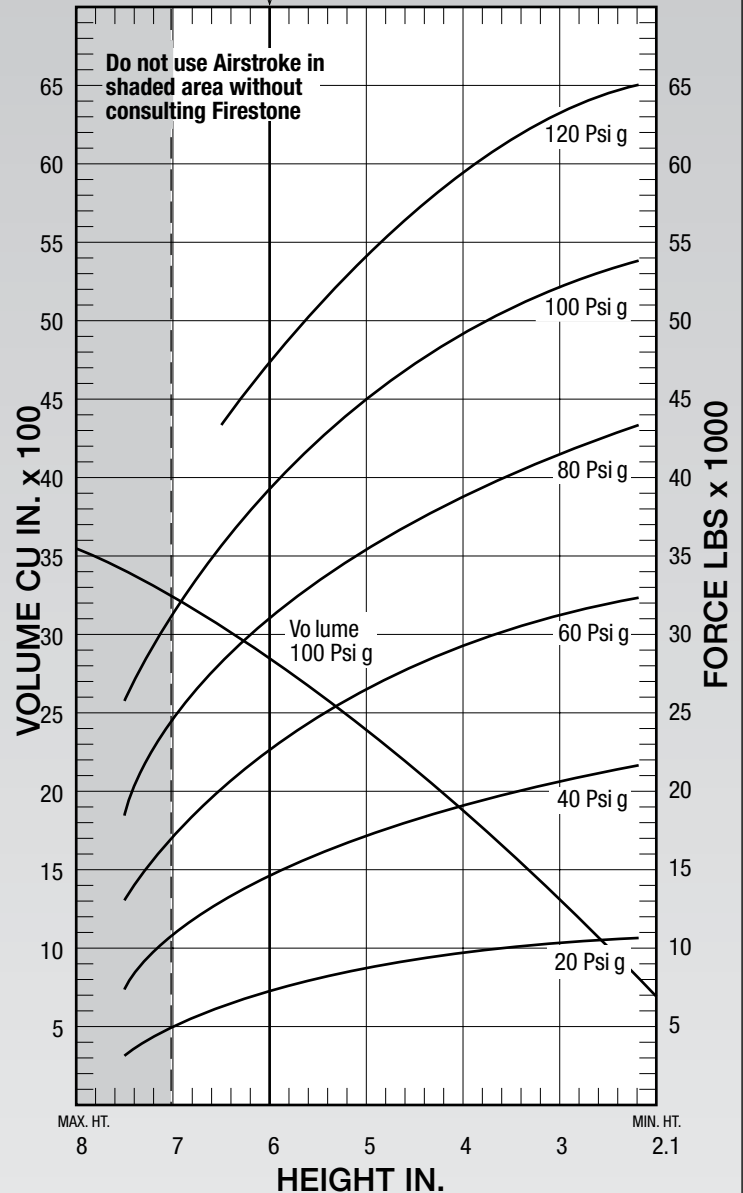
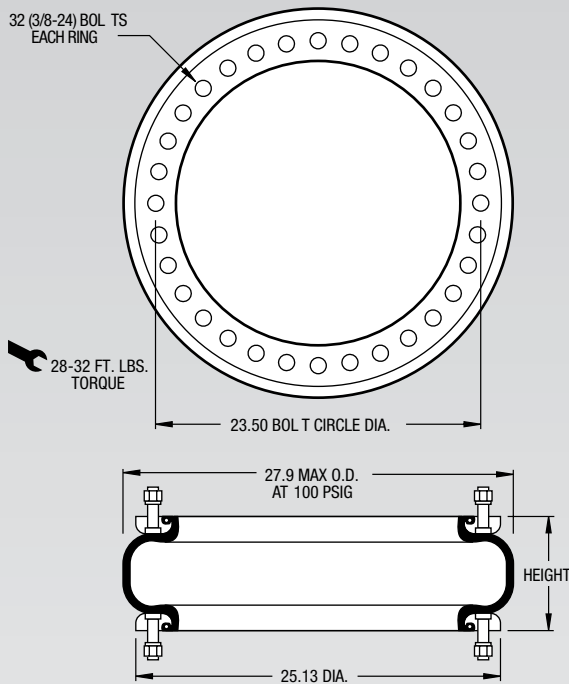

See page 12 for instructions on how to use chart.

Dynamic Characteristics at 6.0 in. Design Height (Required for Airmount isolator design only)				
Volume @ 100 PSIG = 2,846 in <sup>3</sup>			Natural Frequency	
Gage Pressure (PSIG)	Load (lbs.)	Spring Rate (lbs./in.)	CPM	HZ
40	15,020	6,932	128	2.13
60	23,040	10,353	125	2.10
80	31,240	12,979	121	2.02
100	39,570	15,786	119	1.98

Force Table (Use for Airstroke™ actuator design)						
Assembly Height (in.)	Volume @ 100 PSIG (in <sup>3</sup> )	Pounds Force				
		@20 PSIG	@40 PSIG	@60 PSIG	@80 PSIG	@100 PSIG
7.0	3,227	5,290	10,830	17,450	24,320	31,630
6.0	2,846	7,290	15,020	23,040	31,240	39,570
5.0	2,402	8,610	17,220	26,410	35,580	44,680
4.0	1,906	9,760	19,630	29,320	39,260	49,620
3.0	1,376	10,200	20,840	31,560	41,930	53,010

# 148-1

# Firestone

# AIRSTROKE™ ACTUATORS

# AIRMOUNT™ ISOLATORS

	Description	Assembly Order No.
Style 148-1	Ribbed neck aluminum bead rings (equal spacing), 1 7/8 bolts, nuts, washers	W01-358-9601
High Strength Bellows	Rubber bellows only	W01-358-1021
Assembly weight .....		72.9 lbs.
Force to collapse to minimum height (@ 0 PSIG)		310 lbs.

Recommended Design Position Static Pressure 0-100 psi

RECOMMENDED AIRMOUNT DESIGN HEIGHT 5.5 INCHES

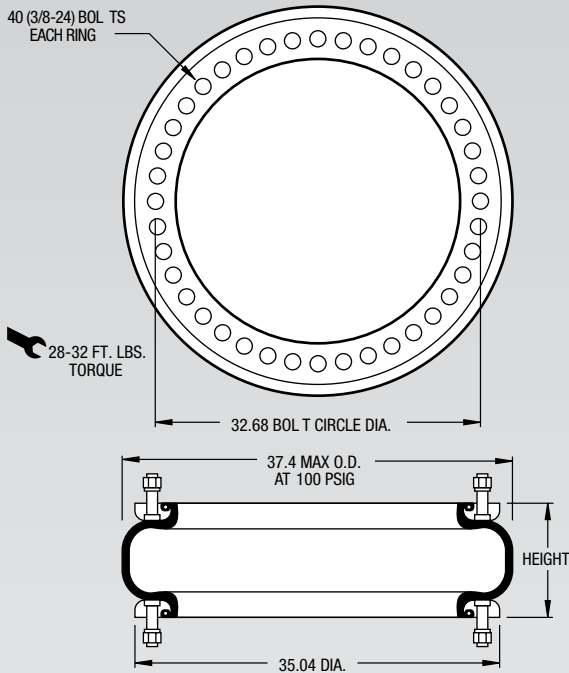

**NOTE:** The effective length of the 1 7/8 bolt is 1.05" in this bead ring.

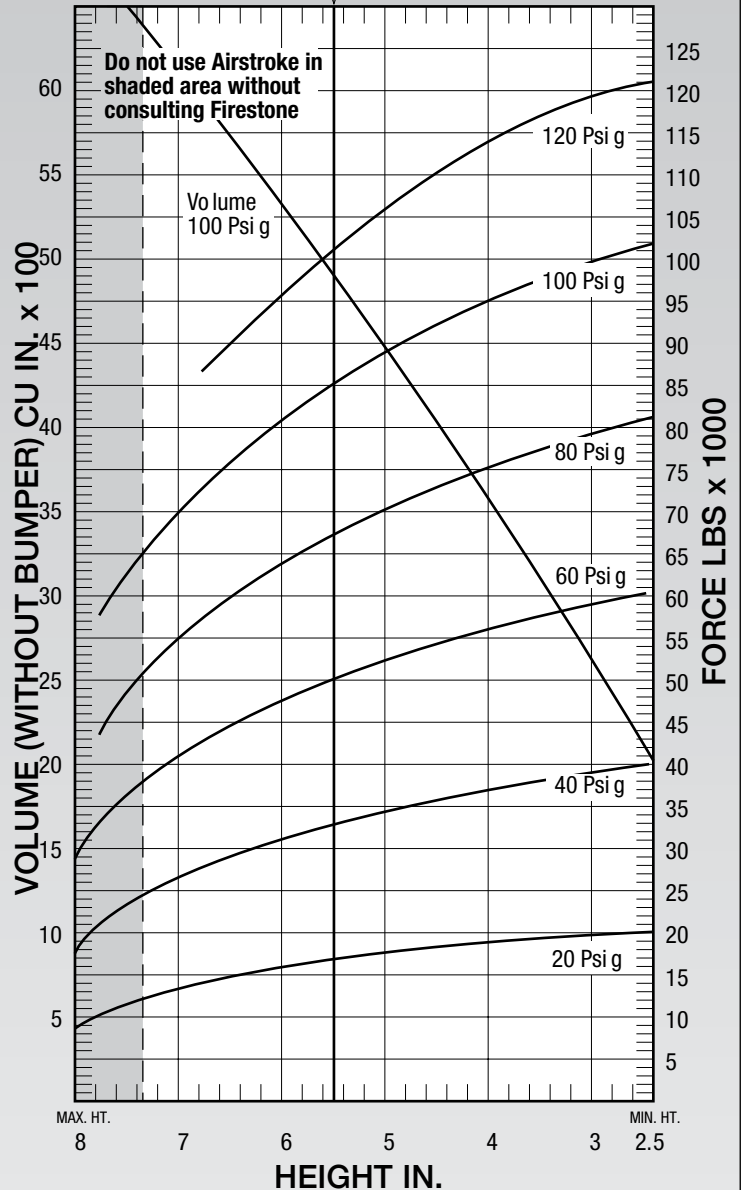

See page 12 for instructions on how to use chart.

Dynamic Characteristics at 5.5 in. Design Height (Required for Airmount isolator design only)				
Volume @ 100 PSIG = 4,914 in <sup>3</sup>			Natural Frequency	
Gage Pressure (PSIG)	Load (lbs.)	Spring Rate (lbs./in.)	CPM	HZ
40	32,860	14,220	123	2.06
60	50,290	19,969	118	1.97
80	67,690	26,697	118	1.96
100	85,200	32,491	116	1.93

Force Table (Use for Airstroke™ actuator design)						
Assembly Height (in.)	Volume @ 100 PSIG (in <sup>3</sup> )	Pounds Force				
		@20 PSIG	@40 PSIG	@60 PSIG	@80 PSIG	@100 PSIG
7.0	6,134	13,470	26,890	41,610	55,830	70,860
6.0	5,337	15,720	31,220	47,920	64,170	80,890
5.0	4,471	17,450	34,310	52,370	70,980	89,140
4.0	3,532	18,810	36,970	56,050	76,330	95,540
3.0	2,542	19,940	39,470	59,360	80,110	100,050

**NOTE: Replacement for Style 25**

Description		Assembly Order No.
Style 268 Two Ply Bellows	Blind nuts, 1/4 NPT	W01-358-7025
	Blind nuts, 3/4 NPT	W01-358-7047
	Blind nuts, 1/4 NPT both ends	W01-358-7035
	3/4 NPT both ends (no blind nuts)	W01-606-7025
	Socket head aluminum bead rings (bolts, nuts, washers not included, use cap screws)	W01-358-0030
	3/4 NPT (only) upper plate, blind nuts lower plate	W01-358-7030
	Rubber bellows only	W01-358-0319
	Assembly weight .....	
Force to collapse to minimum height (@ 0 PSIG)...		30 lbs.

Recommended Design Position Static Pressure 0-100 psi

RECOMMENDED AIRMOUNT DESIGN HEIGHT 5.5 INCHES

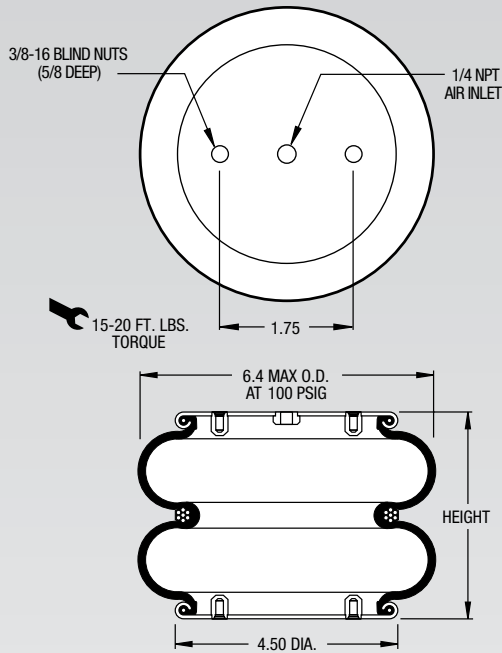
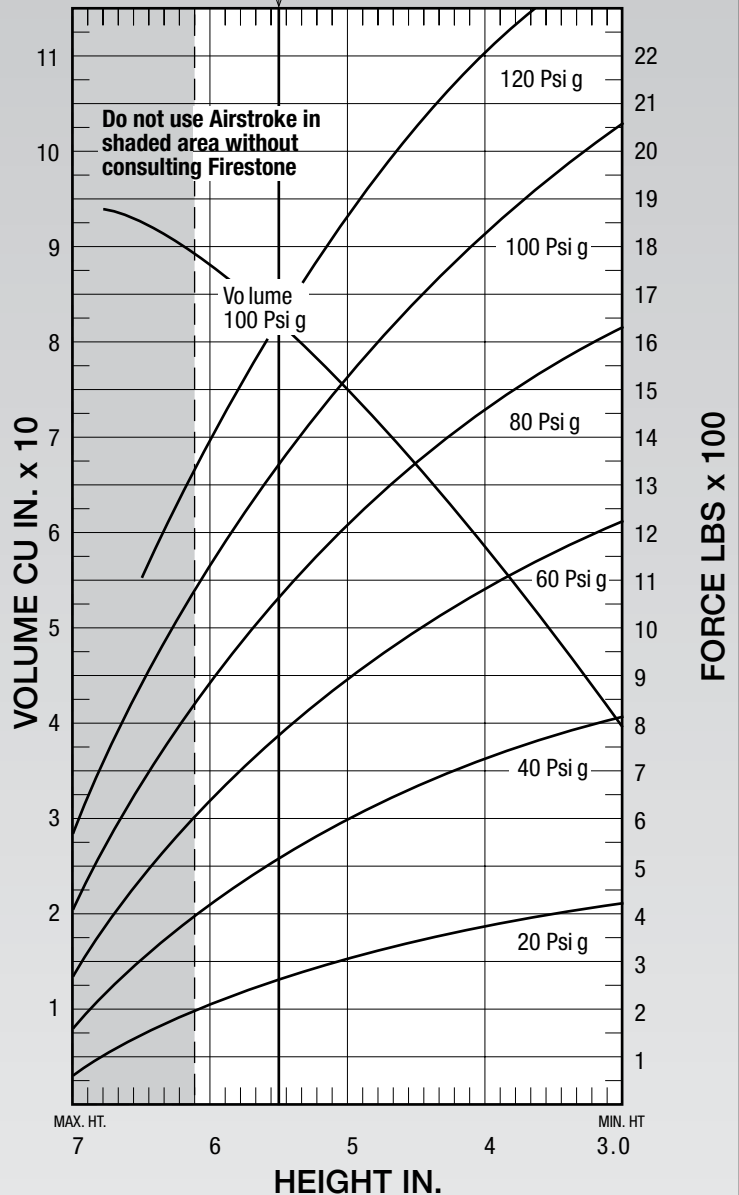

**NOTE: A bead plate part is shown. This part is also available with bead rings. Bolts are not included. See pages 8-10 for explanation.**

See page 12 for instructions on how to use chart.

Dynamic Characteristics at 5.5 in. Design Height (Required for Airmount isolator design only)				
Volume @ 100 PSIG = 86 in <sup>3</sup>			Natural Frequency	
Gage Pressure (PSIG)	Load (lbs.)	Spring Rate (lbs./in.)	CPM	HZ
40	515	339	153	2.54
60	787	482	147	2.45
80	1,062	634	145	2.42
100	1,360	773	141	2.36

Force Table (Use for Airstroke™ actuator design)						
Assembly Height (in.)	Volume @ 100 PSIG (in <sup>3</sup> )	Pounds Force				
		@20 PSIG	@40 PSIG	@60 PSIG	@80 PSIG	@100 PSIG
5.0	78	300	590	890	1,210	1,540
4.0	60	380	720	1,080	1,450	1,810
3.0	39	420	800	1,220	1,640	2,060

# 267-1.5

# Firestone

# AIRSTROKE™ ACTUATORS

# AIRMOUNT™ ISOLATORS

**NOTE: Replacement  
for Style 255-1.5**

Description		Assembly Order No.
Style 255-1.5	Blind nuts, 1/4 NPT	W01-358-6955
	Blind nuts, 3/4 NPT	W01-358-6956
Two Ply Bellows	Rubber bellows only	W01-358-0048
	Socket head aluminum bead rings (bolts, nuts, washers not included, use cap screws)	W01-358-6833
Assembly weight .....		3.3 lbs.
Force to collapse to minimum height (@ 0 PSIG)...		50 lbs.

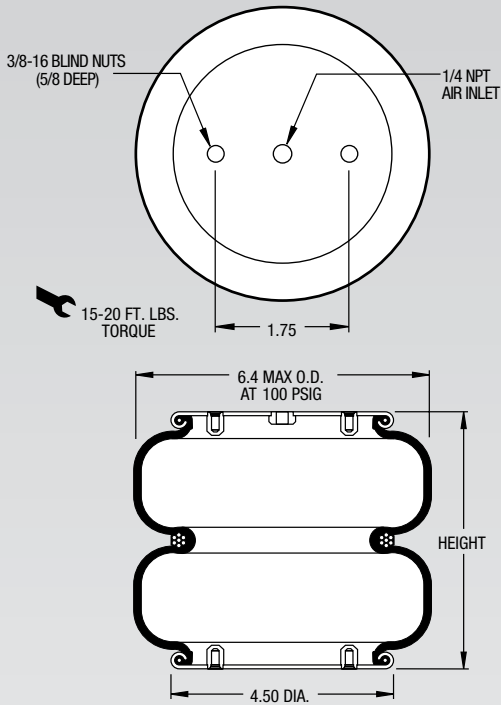

**NOTE: A bead plate part is shown. This part is also available with bead rings. Bolts are not included. See pages 8-10 for explanation.**

Dynamic Characteristics at 6.0 in. Design Height (Required for Airmount isolator design only)				
Volume @ 100 PSIG = 100 in <sup>3</sup>			Natural Frequency	
Gage Pressure (PSIG)	Load (lbs.)	Spring Rate (lbs./in.)	CPM	HZ
40	566	309	139	2.32
60	871	432	132	2.21
80	1,194	565	129	2.16
100	1,524	681	126	2.10

CONSULT FIRESTONE BEFORE USING AS AIRMOUNT

RECOMMENDED AIRMOUNT DESIGN HEIGHT 6.0 INCHES

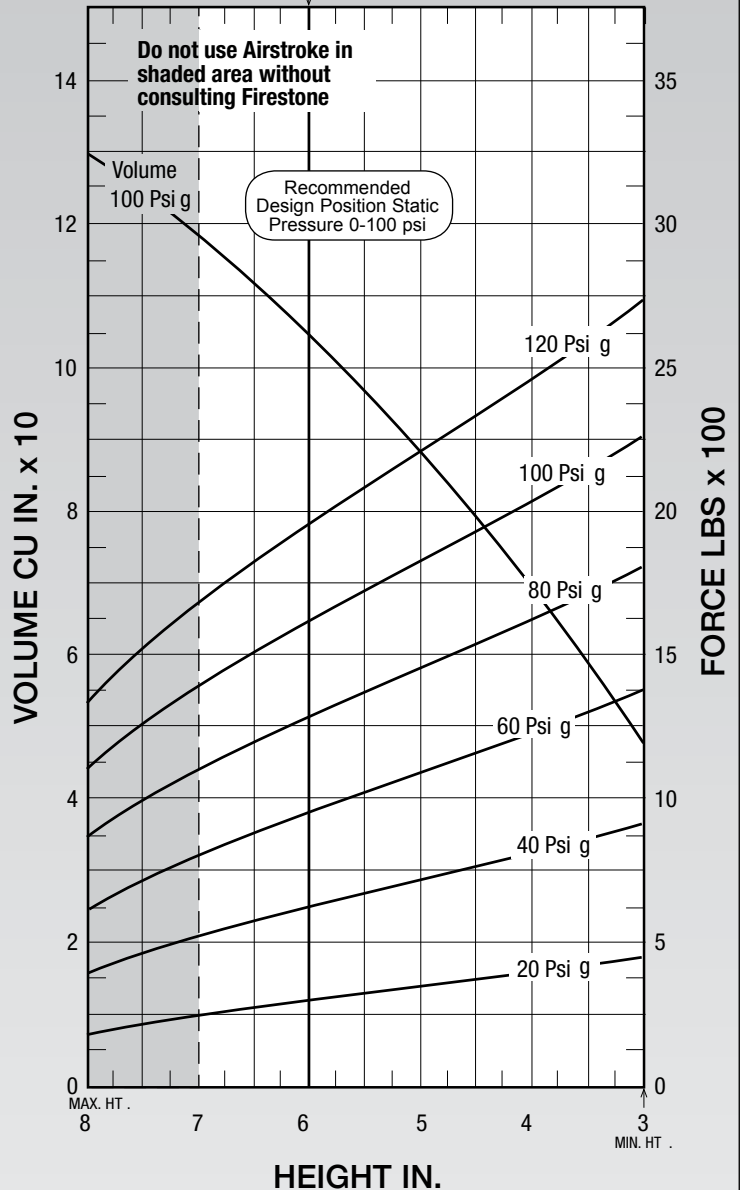

See page 12 for instructions on how to use chart.

Force Table (Use for Airstroke™ actuator design)						
Assembly Height (in.)	Volume @ 100 PSIG (in <sup>3</sup> )	Pounds Force				
		@20 PSIG	@40 PSIG	@60 PSIG	@80 PSIG	@100 PSIG
7.0	125	267	534	801	1,069	1,336
6.0	109	333	667	1,000	1,333	1,667
5.0	91	381	763	1,144	1,525	1,907
4.0	71	416	833	1,249	1,666	2,082

Description		Assembly Order No.
Style 224	Blind nuts, 1/4 NPT	W01-358-3400
	Blind nuts, 3/4 NPT	W01-358-3403
Two Ply Bellows	Countersunk steel bead rings, 1 3/4 bolts, nuts, washers,	W01-358-3407
Assembly weight .....		5.0 lbs.
Force to collapse to minimum height (@ 0 PSIG)...		14 lbs.

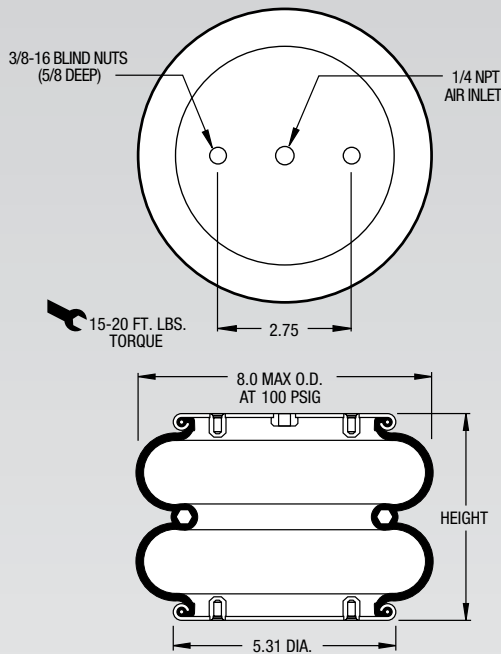

**NOTE:** A bead plate part is shown. This part is also available with bead rings. See pages 8-10 for explanation.

Dynamic Characteristics at 6.5 in. Design Height (Required for Airmount isolator design only)				
Volume @ 100 PSIG = 171 in <sup>3</sup>			Natural Frequency	
Gage Pressure (PSIG)	Load (lbs.)	Spring Rate (lbs./in.)	CPM	HZ
40	730	361	132	2.20
60	1,130	523	128	2.13
80	1,530	690	126	2.10
100	1,940	849	124	2.07

Recommended Design Position Static Pressure 0-100 psi

RECOMMENDED AIRMOUNT DESIGN HEIGHT 6.5 INCHES

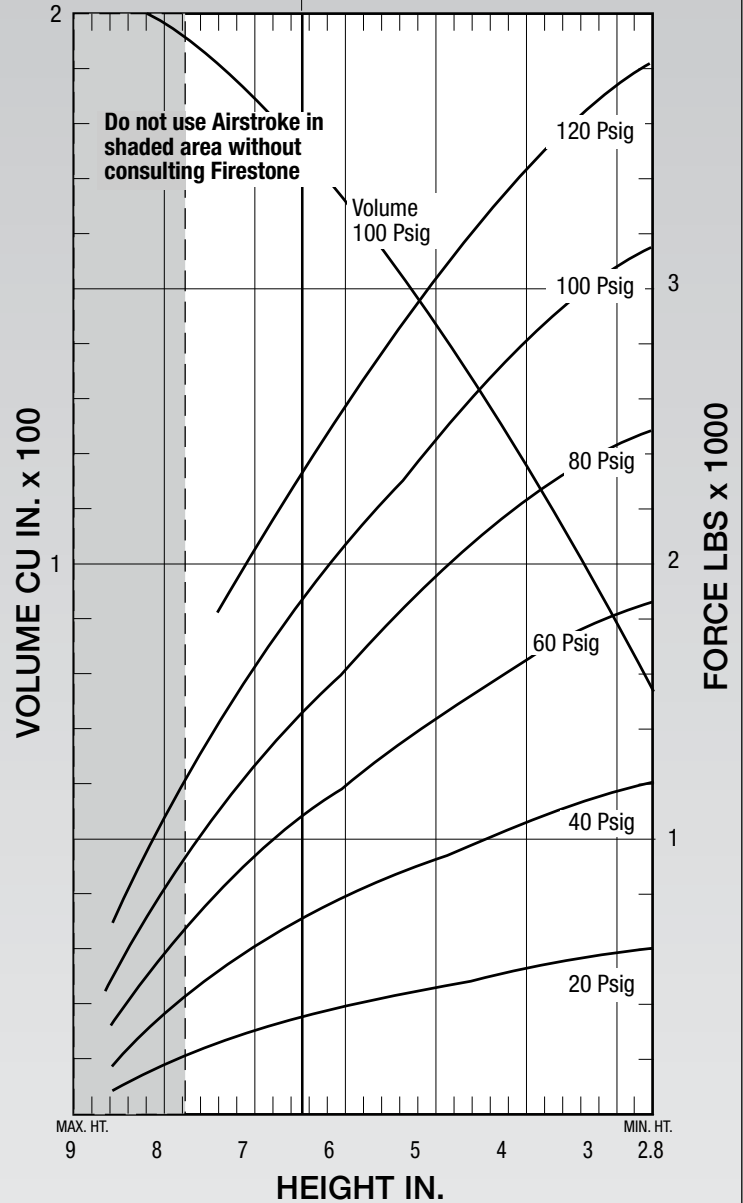

See page 12 for instructions on how to use chart.

Force Table (Use for Airstroke™ actuator design)						
Assembly Height (in.)	Volume @ 100 PSIG (in <sup>3</sup> )	Pounds Force				
		@20 PSIG	@40 PSIG	@60 PSIG	@80 PSIG	@100 PSIG
7.0	181	320	630	990	1,340	1,710
6.0	160	400	820	1,260	1,700	2,160
5.0	134	470	960	1,490	2,040	2,570
4.0	105	550	1,110	1,720	2,310	2,930
3.0	73	590	1,210	1,860	2,480	3,150

Description		Assembly Order No.
Style 26	Blind nuts, 1/4 NPT	W01-358-7325
	Blind nuts, 3/4 NPT	W01-358-7327
Two Ply Bellows	Countersunk steel bead rings, 1 3/4 bolts, nuts, washers	W01-358-7333
	Rubber bellows only	W01-358-0142
Assembly weight .....		5.3 lbs.
Force to collapse to minimum height (@ 0 PSIG)...		23 lbs.

Recommended Design Position Static Pressure 0-100 psi

RECOMMENDED AIRMOUNT DESIGN HEIGHT 8.0 INCHES

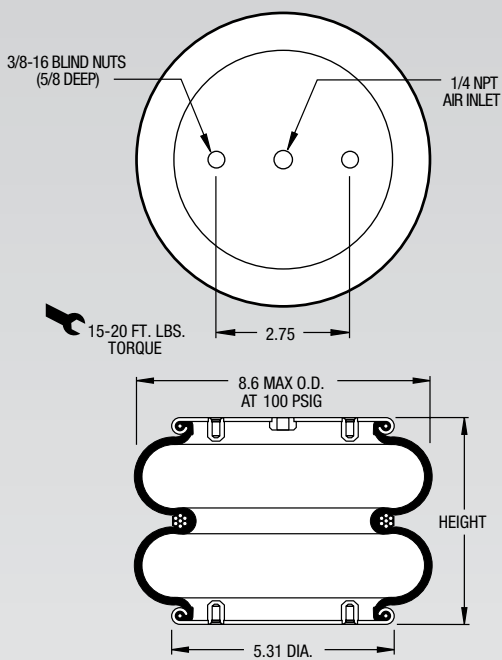

NOTE: A bead plate part is shown. This part is also available with bead rings. See pages 8-10 for explanation.

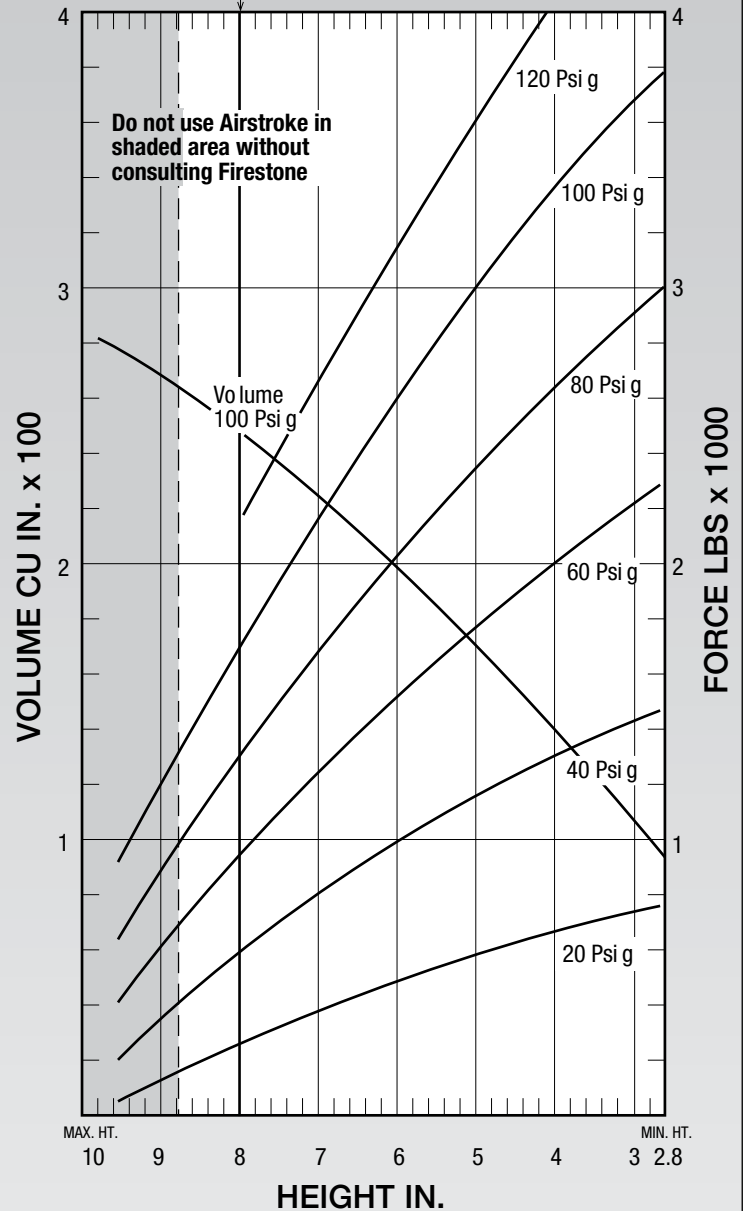

MAX. HT. 10 9 8 7 6 5 4 3 2.8 MIN. HT.

HEIGHT IN.

See page 12 for instructions on how to use chart.

Dynamic Characteristics at 8.0 in. Design Height (Required for Airmount isolator design only)				
Volume @ 100 PSIG = 246 in <sup>3</sup>			Natural Frequency	
Gage Pressure (PSIG)	Load (lbs.)	Spring Rate (lbs./in.)	CPM	HZ
40	590	348	144	2.41
60	980	451	128	2.13
80	1,360	589	123	2.04
100	1,780	732	121	2.01

Force Table (Use for Airstroke™ actuator design)						
Assembly Height (in.)	Volume @ 100 PSIG (in <sup>3</sup> )	Pounds Force				
		@20 PSIG	@40 PSIG	@60 PSIG	@80 PSIG	@100 PSIG
8.0	246	270	590	980	1,360	1,780
7.0	233	390	810	1,270	1,740	2,240
6.0	196	480	1,010	1,530	2,060	2,630
5.0	164	570	1,180	1,780	2,420	3,110
4.0	128	660	1,340	2,010	2,750	3,510

NOTE: Replacement for Style 20

Recommended Design Position Static Pressure 0-100 psi

RECOMMENDED AIRMOUNT DESIGN HEIGHT 8.5 INCHES

Description		Assembly Order No.
Style 274	Blind nuts, 1/4 NPT	W01-358-6910
	Blind nuts, 1/4 NPT, bumper	W01-358-6911
Two Ply Bellows	Blind nuts, 3/4 NPT	W01-358-6900
	Blind nuts, 3/4 NPT, bumper	W01-358-6901
	Countersunk steel bead rings, 1 3/4 bolts, nuts, washers	W01-358-6923
	Rubber bellows only	W01-358-0138

Assembly weight ..... 7.0 lbs.

Force to collapse to minimum height (@ 0 PSIG)... 14 lbs.

Style 202	Blind nuts, 1/4 NPT	W01-358-7080
High Strength Bellows	Blind nuts, 3/4 NPT	W01-358-7119

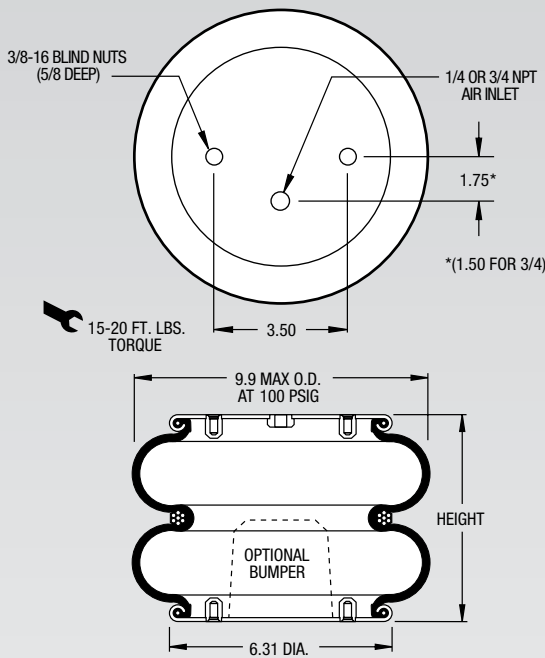

NOTE: A bead plate part is shown. This part is also available with bead rings. See pages 8-10 for explanation.

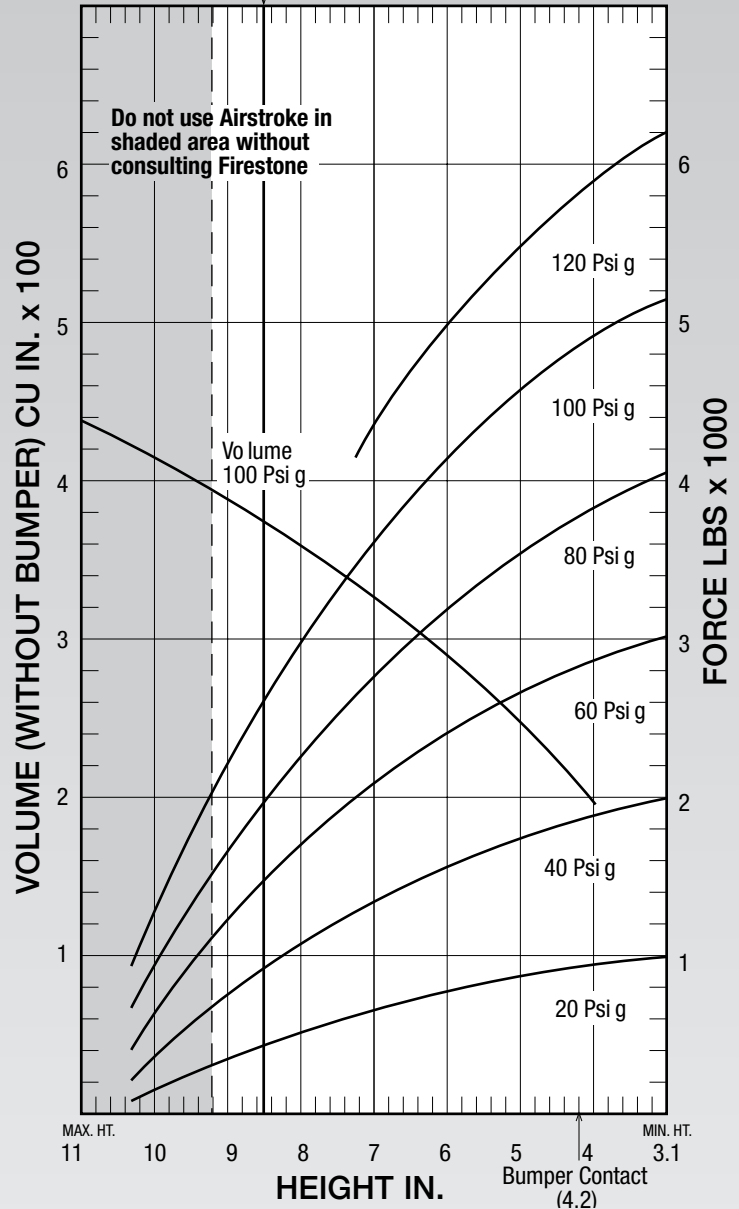

See page 12 for instructions on how to use chart.

Dynamic Characteristics at 8.5 in. Design Height (Required for Airmount isolator design only)				
Volume @ 100 PSIG = 376 in <sup>3</sup>			Natural Frequency	
Gage Pressure (PSIG)	Load (lbs.)	Spring Rate (lbs./in.)	CPM	HZ
40	990	414	121	2.02
60	1,540	615	119	1.98
80	2,130	820	116	1.94
100	2,720	996	114	1.89

Force Table (Use for Airstroke™ actuator design)						
Assembly Height (in.)	Volume @ 100 PSIG (in <sup>3</sup> )	Pounds Force				
		@20 PSIG	@40 PSIG	@60 PSIG	@80 PSIG	@100 PSIG
9.0	392	392	770	1,195	1,642	2,114
8.0	365	576	1,128	1,713	2,309	2,940
7.0	331	707	1,396	2,104	2,832	3,582
6.0	291	806	1,601	2,410	3,237	4,082
5.0	247	903	1,796	2,702	3,624	4,562
4.0	197	993	1,966	2,953	3,948	4,958

	Description	Assembly Order No.
Style 20-2	Blind nuts, 1/4 NPT	W01-358-6951
	Blind nuts, 1/4 NPT, rubber bumper	W01-358-6947
Two Ply Bellows	Blind nuts, 3/4 NPT	W01-358-6952
	Countersunk steel bead rings, 1 3/4 bolts, nuts, washers	W01-358-7789
	Rubber bellows only	W01-358-0305
Assembly weight .....		7.7 lbs.
Force to collapse to minimum height (@ 0 PSIG).....		17 lbs.

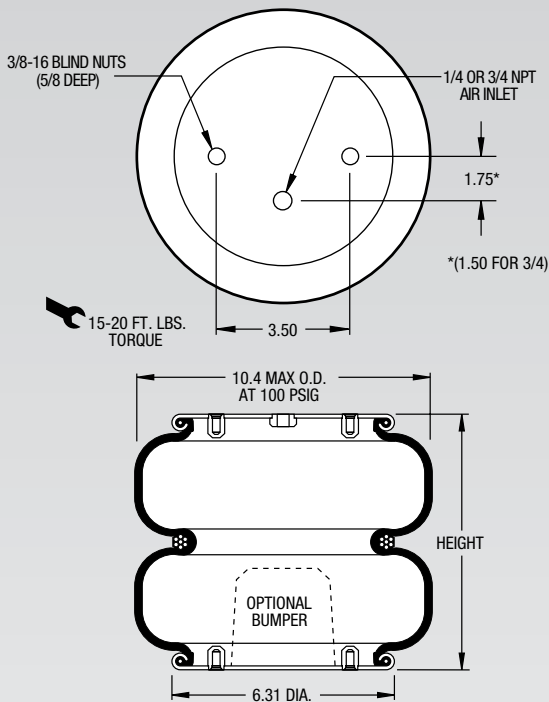

**NOTE:** The bellows extends beyond the bead plates at minimum height

**NOTE:** A bead plate part is shown. This part is also available with bead rings. See pages 8-10 for explanation.

Dynamic Characteristics at 10.0 in. Design Height Consult factory before using as an Airmount isolator.				
Volume @ 100 PSIG = 488 in <sup>3</sup>			Natural Frequency	
Gage Pressure (PSIG)	Load (lbs.)	Spring Rate (lbs./in.)	CPM	HZ
40	1,184	376	106	1.77
60	1,848	534	101	1.68
80	2,531	669	97	1.61
100	3,238	813	94	1.57

CONSULT FIRESTONE BEFORE USING AS AIRMOUNT  
RECOMMENDED AIRMOUNT DESIGN HEIGHT 10.0 INCHES

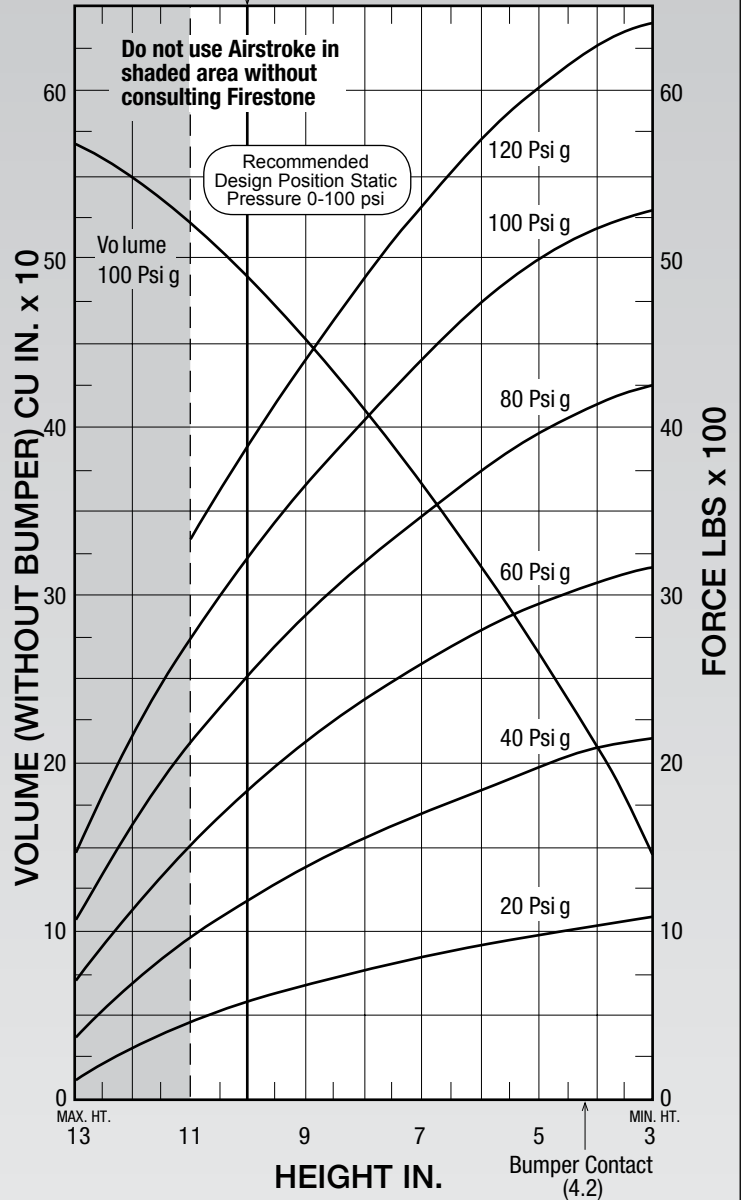

See page 12 for instructions on how to use chart.

Force Table (Use for Airstroke™ actuator design)						
Assembly Height (in.)	Volume @ 100 PSIG (in <sup>3</sup> )	Pounds Force				
		@20 PSIG	@40 PSIG	@60 PSIG	@80 PSIG	@100 PSIG
11.0	520	449	951	1,517	2,122	2,753
10.0	488	572	1,184	1,848	2,531	3,238
9.0	451	673	1,384	2,134	2,880	3,661
8.0	409	759	1,554	2,377	3,193	4,049
7.0	364	836	1,704	2,590	3,485	4,416
6.0	316	907	1,845	2,786	3,753	4,748
5.0	256	975	1,979	2,954	3,968	5,005



Description		Assembly Order No.
Style 22	Blind nuts, 1/4 NPT	W01-358-7180
	Blind nuts, 1/4 NPT, bumper	W01-358-7400
Two Ply Bellows	Blind nuts, 3/4 NPT	W01-358-7184
	Blind nuts, 3/4 NPT, bumper	W01-358-7185
	Countersunk steel bead rings, 1 <sup>5</sup> / <sub>8</sub> bolts, nuts, washers	W01-358-7431
	Rubber bellows only	W01-358-0226
	Assembly weight .....	
Force to collapse to minimum height (@ 0 PSIG)...		20 lbs.

Style 210	Blind nuts, 1/4 NPT	W01-358-7251
	Blind nuts, 1/4 NPT, bumper	W01-358-7291
High Strength Bellows	Blind nuts, 3/4 NPT	W01-358-7250
	Countersunk steel bead rings, 1 <sup>3</sup> / <sub>4</sub> bolts, nuts, washers	W01-358-7258
	Rubber bellows only	W01-358-7928

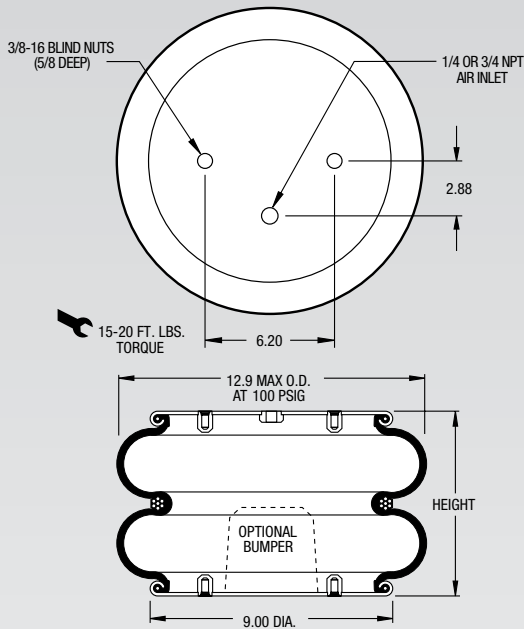

**NOTE:** A bead plate part is shown. This part is also available with bead rings. See pages 8-10 for explanation.

Dynamic Characteristics at 9.5 in. Design Height (Required for Airmount isolator design only)				
Volume @ 100 PSIG = 782 in <sup>3</sup>			Natural Frequency	
Gage Pressure (PSIG)	Load (lbs.)	Spring Rate (lbs./in.)	CPM	HZ
40	2,050	729	112	1.86
60	3,170	1,036	107	1.79
80	4,280	1,373	106	1.77
100	5,400	1,668	104	1.74

Recommended Design Position Static Pressure 0-100 psi

RECOMMENDED AIRMOUNT DESIGN HEIGHT 9.5 INCHES

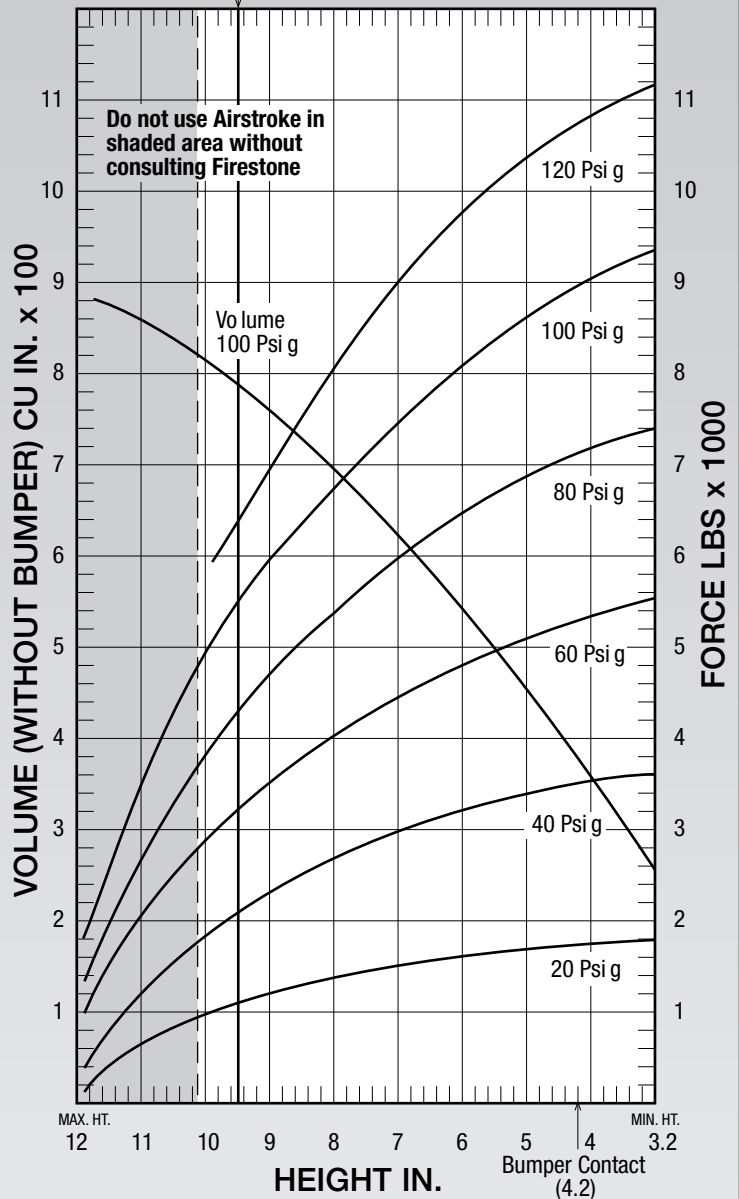

See page 12 for instructions on how to use chart.

Force Table (Use for Airstroke™ actuator design)						
Assembly Height (in.)	Volume @ 100 PSIG (in <sup>3</sup> )	Pounds Force				
		@20 PSIG	@40 PSIG	@60 PSIG	@80 PSIG	@100 PSIG
10.0	809	950	1,810	2,830	3,810	4,840
9.0	752	1,170	2,260	3,460	4,670	5,880
8.0	685	1,310	2,590	3,940	5,350	6,700
7.0	610	1,430	2,900	4,390	5,950	7,450
6.0	529	1,540	3,170	4,780	6,470	8,110
5.0	442	1,640	3,380	5,100	6,880	8,630
4.0	349	1,730	3,520	5,340	7,180	9,020

# 22-1.5

# Firestone

# AIRSTROKE™ ACTUATORS

# AIRMOUNT™ ISOLATORS

	Description	Assembly Order No.
Style 22-1.5	Blind nuts, 1/4 NPT	W01-358-7444
	Blind nuts, 1/4 NPT, rubber bumper	W01-358-7473
Two Ply Bellows	Blind nuts, 3/4 NPT	W01-358-7442
	Blind nuts, 1/4 NPT(centered)	W01-358-7443
	Rubber bellows only	W01-358-0259
	Countersunk steel bead rings, 1 5/8 bolts, nuts, washers	W01-358-7480
Assembly weight .....		12.9 lbs.
Force to collapse to minimum height (@ 0 PSIG)...		26 lbs.

Recommended Design Position Static Pressure 0-100 psi

RECOMMENDED AIRMOUNT DESIGN HEIGHT 10.5 INCHES

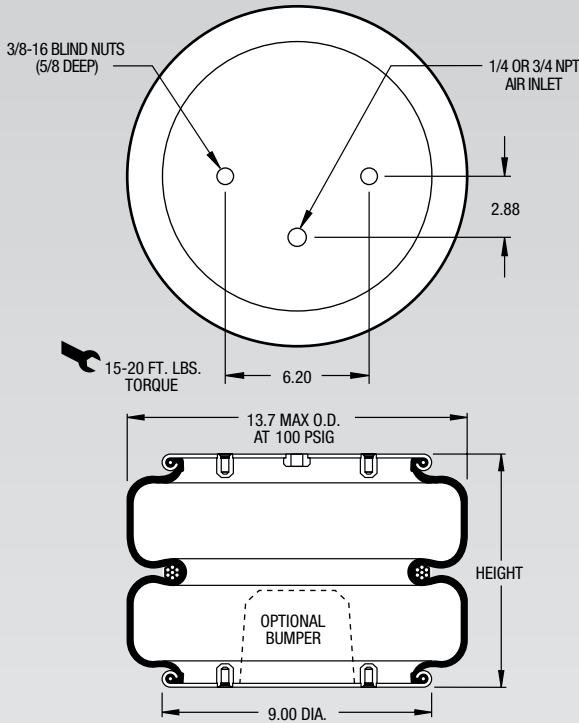

**NOTE:** The bellows extends beyond the bead plates at minimum height.

**NOTE:** A bead plate part is shown. This part is also available with bead rings. See pages 8-10 for explanation.

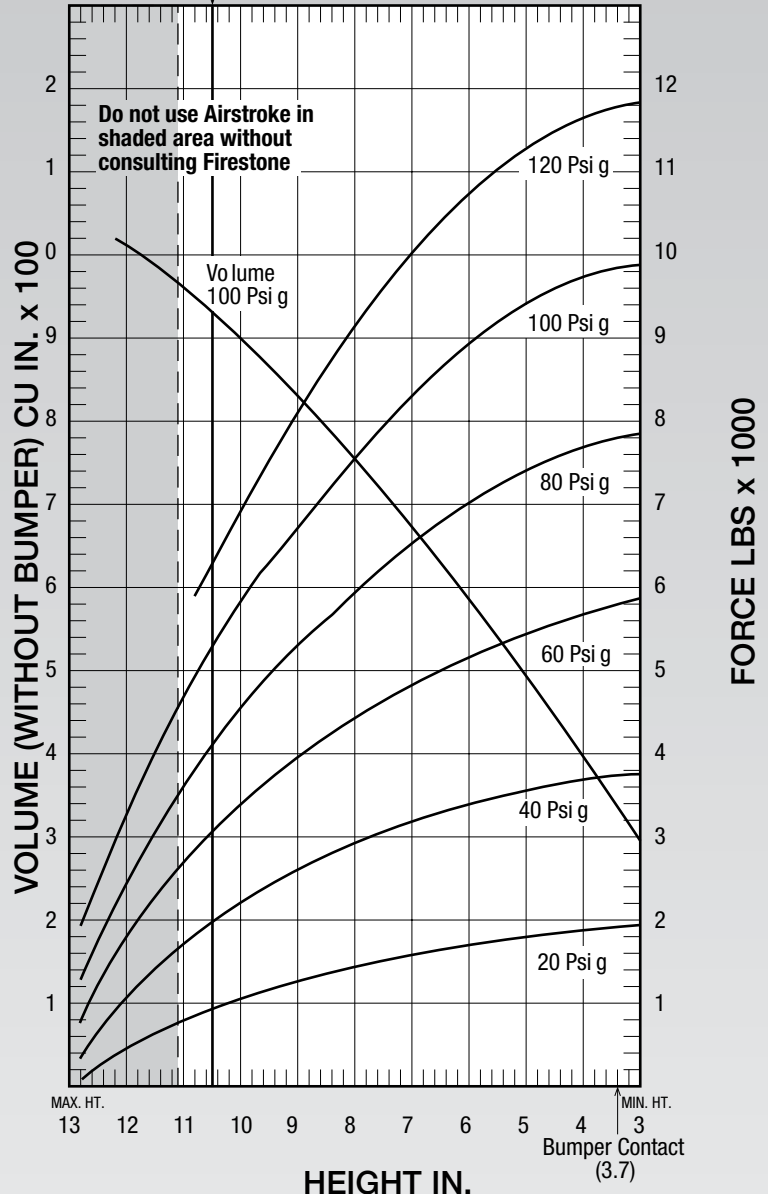

See page 12 for instructions on how to use chart.

Dynamic Characteristics at 10.5 in. Design Height (Required for Airmount isolator design only)				
Volume @ 100 PSIG = 935 in <sup>3</sup>			Natural Frequency	
Gage Pressure (PSIG)	Load (lbs.)	Spring Rate (lbs./in.)	CPM	HZ
40	1,930	684	112	1.86
60	3,030	999	108	1.80
80	4,130	1,319	106	1.77
100	5,310	1,630	104	1.73

Force Table (Use for Airstroke™ actuator design)						
Assembly Height (in.)	Volume @ 100 PSIG (in <sup>3</sup> )	Pounds Force				
		@20 PSIG	@40 PSIG	@60 PSIG	@80 PSIG	@100 PSIG
10.0	905	1,040	2,140	3,340	4,550	5,830
9.0	838	1,220	2,520	3,880	5,250	6,700
8.0	763	1,370	2,850	4,360	5,850	7,450
7.0	681	1,510	3,150	4,810	6,430	8,170
6.0	591	1,650	3,400	5,210	6,990	8,860
5.0	496	1,760	3,590	5,520	7,420	9,380
4.0	396	1,840	3,730	5,730	7,680	9,700

Description		Assembly Order No.
Style 21	Blind nuts, 1/4 NPT	W01-358-7145
	Blind nuts, 1/4 NPT, bumper	W01-358-7146
Two Ply Bellows	Blind nuts, 3/4 NPT	W01-358-7143
	Blind nuts, 3/4 NPT, bumper	W01-358-7144
	Countersunk steel bead rings, 1 3/4 bolts, nuts, washers	W01-358-7139
	Rubber bellows only	W01-358-0213
Assembly weight .....		17.3 lbs
Force to collapse to minimum height (@ 0 PSIG)...		22 lbs.

Style 205	Blind nuts, 1/4 NPT	W01-358-7208
	Blind nuts, 1/4 NPT, bumper	W01-358-7221
High Strength Bellows	Blind nuts, 3/4 NPT	W01-358-7224
	Countersunk steel bead rings, 1 3/4 bolts, nuts, washers	W01-358-7237
	Rubber bellows only	W01-358-7929

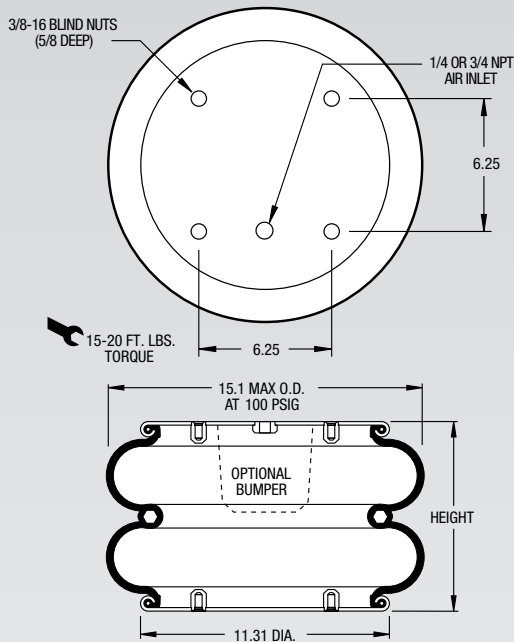

**NOTE:** A bead plate part is shown. This part is also available with bead rings. See pages 8-10 for explanation.

Dynamic Characteristics at 9.5 in. Design Height (Required for Airmount isolator design only)				
Volume @ 100 PSIG = 1,136 in <sup>3</sup>			Natural Frequency	
Gage Pressure (PSIG)	Load (lbs.)	Spring Rate (lbs./in.)	CPM	HZ
40	3,030	1,110	114	1.89
60	4,750	1,582	108	1.80
80	6,540	2,044	105	1.75
100	8,330	2,500	103	1.71

Recommended Design Position Static Pressure 0-100 psi  
RECOMMENDED AIRMOUNT DESIGN HEIGHT 9.5 INCHES

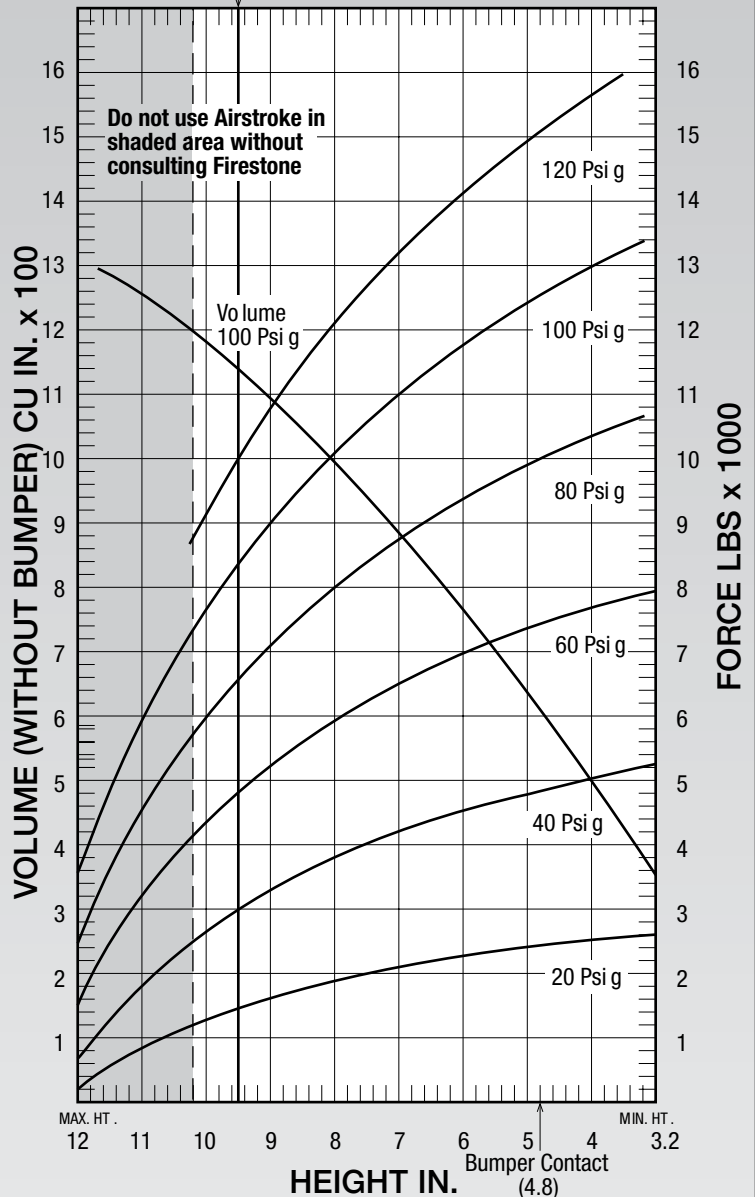

See page 12 for instructions on how to use chart.

Force Table (Use for Airstroke™ actuator design)						
Assembly Height (in.)	Volume @ 100 PSIG (in <sup>3</sup> )	Pounds Force				
		@20 PSIG	@40 PSIG	@60 PSIG	@80 PSIG	@100 PSIG
10.0	1,180	1,260	2,670	4,240	5,890	7,550
9.0	1,091	1,590	3,330	5,180	7,100	9,010
8.0	989	1,810	3,800	5,850	7,980	10,120
7.0	878	2,000	4,180	6,400	8,700	11,020
6.0	758	2,160	4,490	6,860	9,310	11,760
5.0	630	2,300	4,760	7,260	9,830	12,400
4.0	497	2,440	5,010	7,620	10,300	12,960

	Description	Assembly Order No.
Style 21-2	Blind nuts, 1/4 NPT	W01-358-6800
	Blind nuts, 1/4 NPT, rubber bumper	W01-358-6801
Two Ply	Blind nuts, 3/4 NPT	W01-358-9529
Bellows	Countersunk steel bead rings, 1 7/8 bolts, nuts, washers	W01-358-9531
Assembly weight .....		17.6 lbs
Force to collapse to minimum height (@ 0 PSIG)...		35 lbs.

Recommended Design Position Static Pressure 0-100 psi

RECOMMENDED AIRMOUNT DESIGN HEIGHT 10.5 INCHES

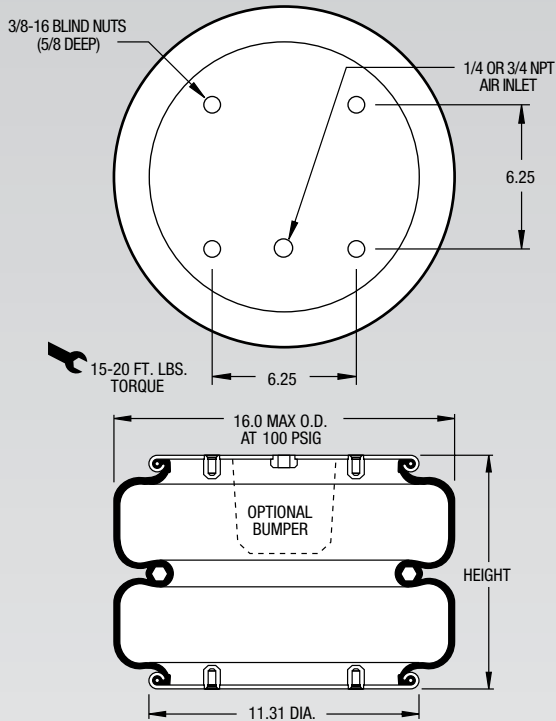

**NOTE:** The bellows extends beyond the bead plates at minimum height.

**NOTE:** A bead plate part is shown. This part is also available with bead rings. See pages 8-10 for explanation.

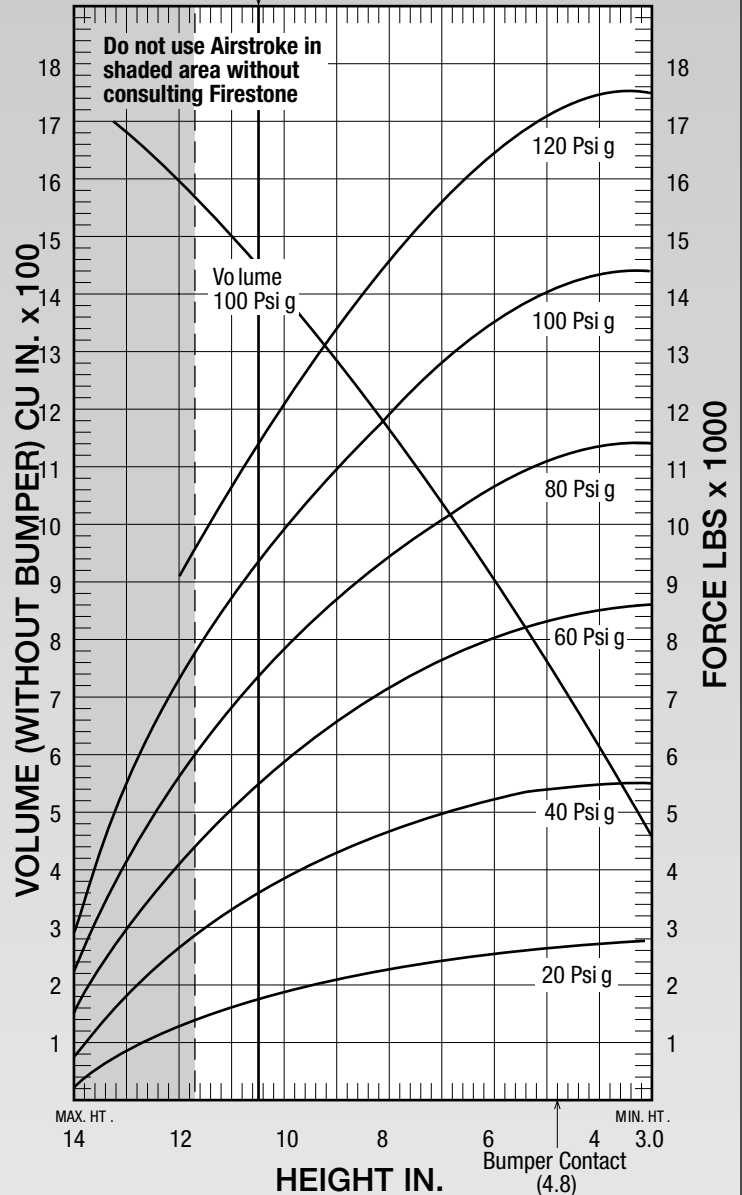

See page 12 for instructions on how to use chart.

Dynamic Characteristics at 10.5 in. Design Height (Required for Airmount isolator design only)				
Volume @ 100 PSIG = 1,462 in <sup>3</sup>			Natural Frequency	
Gage Pressure (PSIG)	Load (lbs.)	Spring Rate (lbs./in.)	CPM	HZ
40	3,460	989	100	1.67
60	5,350	1,437	97	1.62
80	7,280	1,850	95	1.58
100	9,210	2,247	93	1.55

Force Table (Use for Airstroke™ actuator design)						
Assembly Height (in.)	Volume @ 100 PSIG (in <sup>3</sup> )	Pounds Force				
		@20 PSIG	@40 PSIG	@60 PSIG	@80 PSIG	@100 PSIG
11.0	1,510	1,540	3,180	4,930	6,730	8,550
10.0	1,410	1,810	3,710	5,730	7,760	9,790
9.0	1,298	2,040	4,150	6,430	8,570	10,780
8.0	1,177	2,240	4,530	7,050	9,290	11,690
7.0	1,048	2,400	4,850	7,570	10,030	12,620
6.0	910	2,530	5,140	8,000	10,670	13,440
5.0	764	2,620	5,370	8,310	11,100	13,990
4.0	615	2,690	5,490	8,490	11,330	14,280

	Description	Assembly Order No.
Style 233-2	Blind nuts, 1/4 NPT	W01-358-6810
	Blind nuts, 1/4 NPT, rubber bumper	W01-358-7781
Two Ply Bellows	Blind nuts, 3/4 NPT	W01-358-6811
	Blind nuts, 3/4 NPT, rubber bumper	W01-358-6819
	Countersunk steel bead rings, 1 7/8 bolts, nuts, washers	W01-358-7558
Assembly weight .....		18.8 lbs
Force to collapse to minimum height (@ 0 PSIG)		100 lbs.

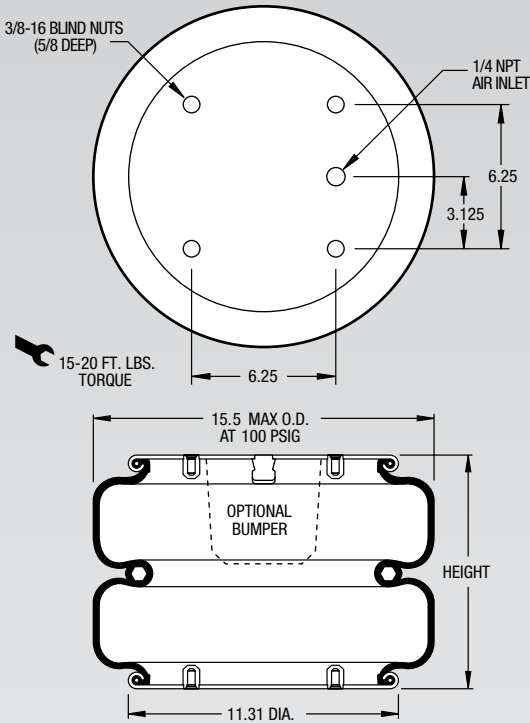

**NOTE:** The bellows extends beyond the bead plates at minimum height.

**NOTE:** A bead plate part is shown. This part is also available with bead rings. See pages 8-10 for explanation.

Dynamic Characteristics at 11.25 in. Design Height (Required for Airmount isolator design only)				
Volume @ 100 PSIG = 1,418 in <sup>3</sup>			Natural Frequency	
Gage Pressure (PSIG)	Load (lbs.)	Spring Rate (lbs./in.)	CPM	HZ
40	3,413	968	100	1.67
60	5,631	1,351	92	1.53
80	7,691	1,735	89	1.49
100	9,917	2,122	87	1.45

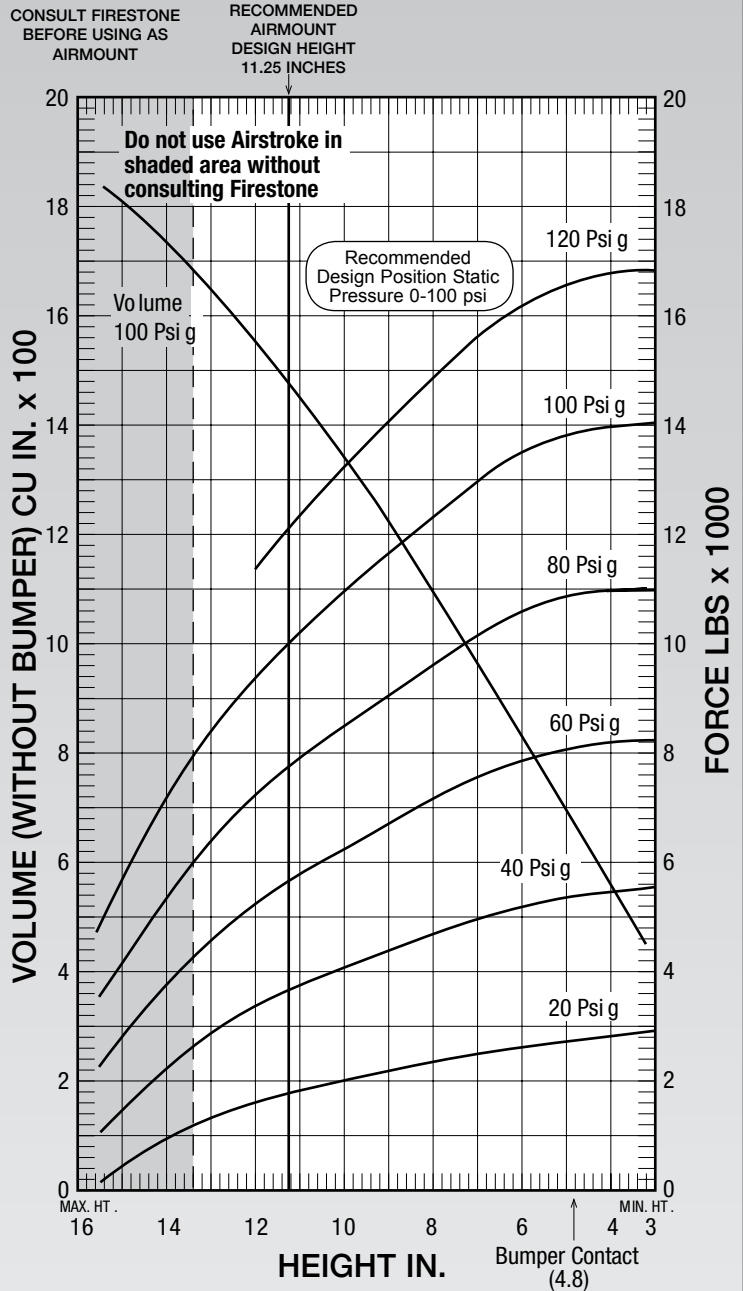

See page 12 for instructions on how to use chart.

Force Table (Use for Airstroke™ actuator design)						
Assembly Height (in.)	Volume @ 100 PSIG (in <sup>3</sup> )	Pounds Force				
		@20 PSIG	@40 PSIG	@60 PSIG	@80 PSIG	@100 PSIG
12.0	1,548	1,542	3,299	5,184	7,194	9,321
10.0	1,333	1,992	4,052	6,239	8,483	10,937
8.0	1,091	2,311	4,666	7,128	9,601	12,333
6.0	829	2,569	5,174	7,485	10,564	13,468
4.0	556	2,793	5,431	8,189	10,966	13,867

Description		Assembly Order No.
Style 28	Ribbed neck aluminum bead rings (equal spacing), 1 7/8 bolts, nuts, washers	W01-358-7191
Two Ply Bellows	Ribbed neck aluminum bead rings (unequal spacing) 1 7/8 b,n,w	W01-358-7194
	Ribbed neck aluminum bead rings (equal spacing) 1 1/4 b,n,w	W01-358-7192
	Rolled plate assembly*, 1/2 blind nut 3/4 NPT	W01-358-7271
	Rubber bellows only	W01-358-7925
Assembly weight .....		18.3 lbs
Force to collapse to minimum height (@ 0 PSIG)...		38 lbs.

Style 201 High Strength Bellows	Ribbed neck aluminum bead rings (equal spacing)	W01-358-7244
	Rubber Bellows Only	W01-139-0201

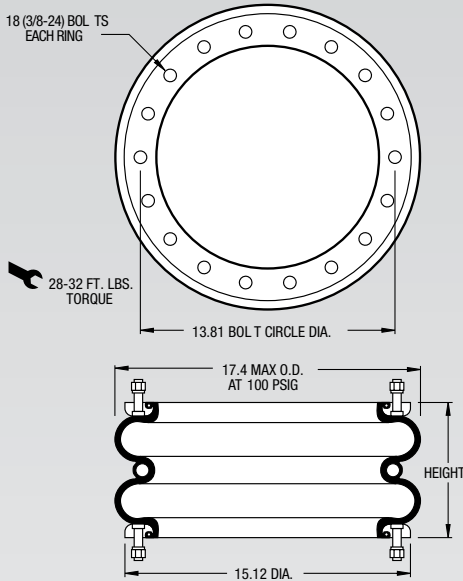

**NOTE:** A bead ring part is shown. This part is also available with rolled plates. See page 11 for explanation.

\*Increase the minimum height by .70 inch. Add .70 inch to the height (bottom axis) before reading loads.

Dynamic Characteristics at 9.5 in. Design Height (Required for Airmount isolator design only)				
Volume @ 100 PSIG = 1,596 in <sup>3</sup>			Natural Frequency	
Gage Pressure (PSIG)	Load (lbs.)	Spring Rate (lbs./in.)	CPM	HZ
40	4,590	1,553	109	1.82
60	7,010	2,125	103	1.72
80	9,590	2,779	101	1.68
100	12,120	3,471	100	1.67

Recommended Design Position Static Pressure 0-100 psi

RECOMMENDED AIRMOUNT DESIGN HEIGHT 9.5 INCHES

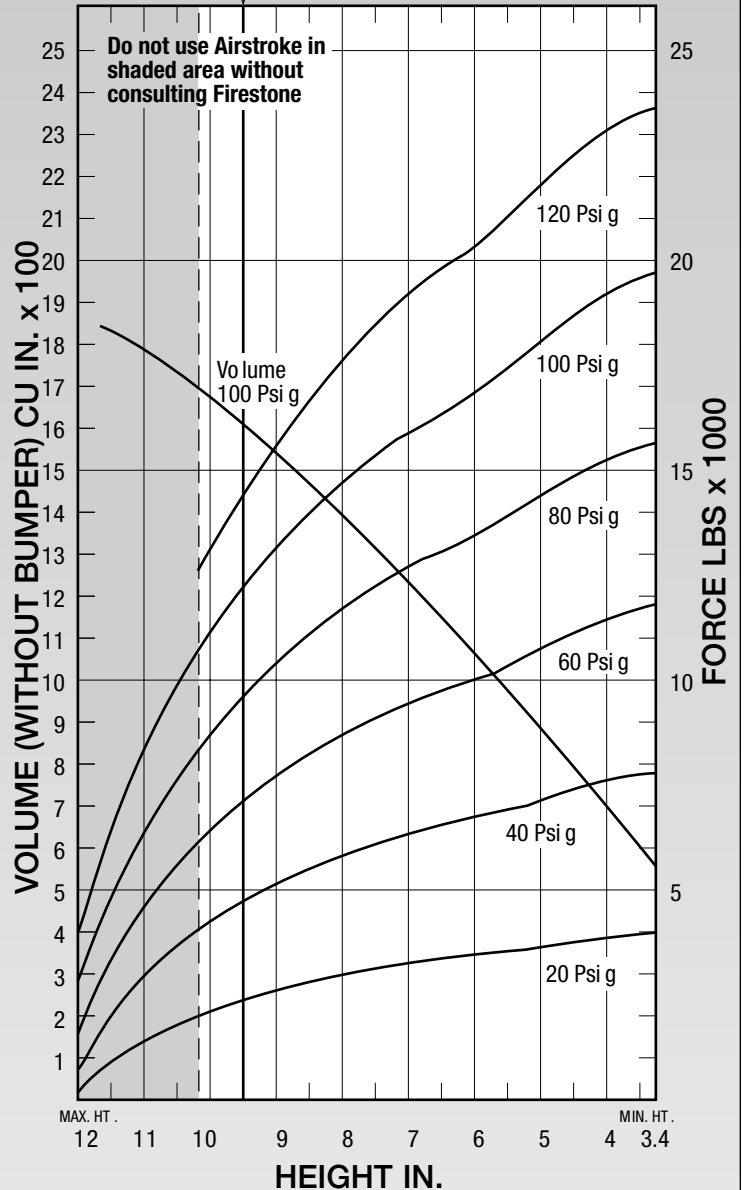

See page 12 for instructions on how to use chart.

Force Table (Use for Airstroke™ actuator design)						
Assembly Height (in.)	Volume @ 100 PSIG (in <sup>3</sup> )	Pounds Force				
		@20 PSIG	@40 PSIG	@60 PSIG	@80 PSIG	@100 PSIG
10.0	1,658	2,090	4,150	6,410	8,780	11,100
9.0	1,529	2,500	5,000	7,550	10,290	13,010
8.0	1,384	2,840	5,700	8,530	11,530	14,550
7.0	1,224	3,110	6,250	9,340	12,580	15,790
6.0	1,053	3,330	6,650	9,940	13,380	16,760
5.0	871	3,590	7,130	10,690	14,380	18,010
4.0	679	3,820	7,570	11,360	15,270	19,130

Description		Assembly Order No.
Style 203	Ribbed neck aluminum bead rings (equal spacing), 1 7/8 bolts, nuts, washers	W01-358-7227
Two Ply Bellows	Ribbed neck aluminum bead rings (equal spacing) 1 1/4 b,n,w	W01-358-7225
	Rolled plate assembly*, 1/2 blind nut 3/4 NPT	W01-358-7273
	Rubber bellows only	W01-358-0205
Assembly weight .....		25.6 lbs
Force to collapse to minimum height (@ 0 PSIG)...		40 lbs.
Style 218	Ribbed neck aluminum bead rings (equal spacing) 1 7/8 bolts, nuts, washers	W01-358-7228
High Strength Bellows		

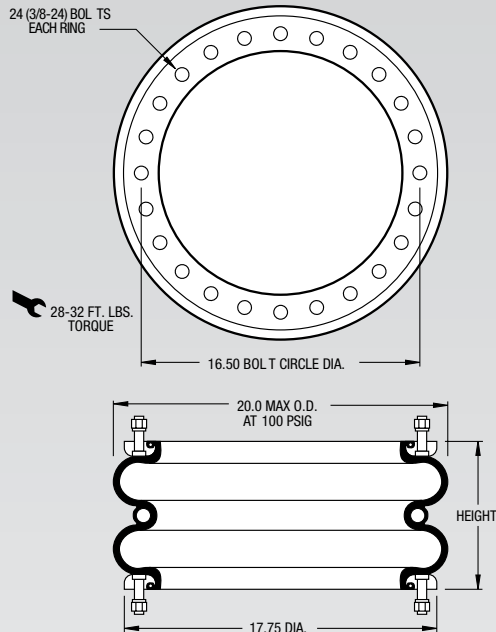

**NOTE:** A bead ring part is shown. This part is also available with rolled plates. See page 11 for explanation.

\*Increase the minimum height by .70 inch. Add .70 inch to the height (bottom axis) before reading loads.

Dynamic Characteristics at 9.5 in. Design Height (Required for Airmount isolator design only)				
Volume @ 100 PSIG = 2,163 in <sup>3</sup>			Natural Frequency	
Gage Pressure (PSIG)	Load (lbs.)	Spring Rate (lbs./in.)	CPM	HZ
40	7,210	2,190	103	1.72
60	11,100	3,150	100	1.67
80	14,970	4,040	97	1.62
100	18,890	4,971	96	1.60

Recommended Design Position Static Pressure 0-100 psi

RECOMMENDED AIRMOUNT DESIGN HEIGHT 9.5 INCHES

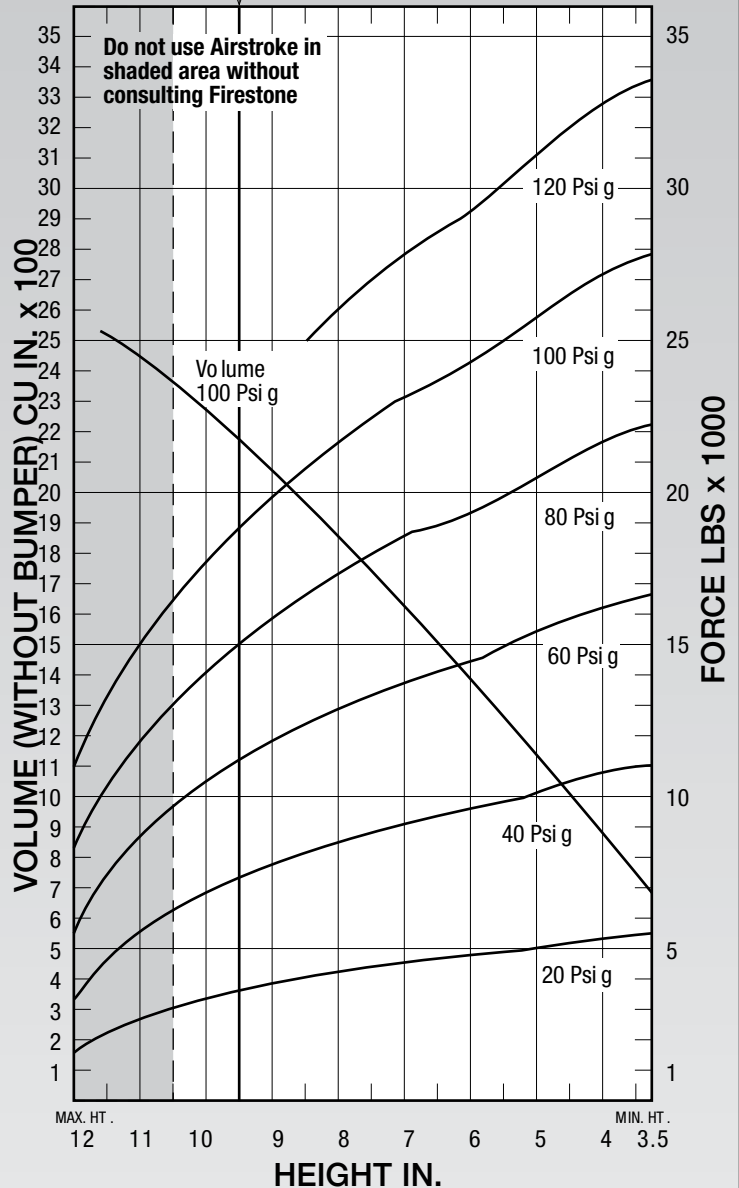

See page 12 for instructions on how to use chart.

Force Table (Use for Airstroke™ actuator design)						
Assembly Height (in.)	Volume @ 100 PSIG (in <sup>3</sup> )	Pounds Force				
		@20 PSIG	@40 PSIG	@60 PSIG	@80 PSIG	@100 PSIG
10.0	2,261	3,330	6,710	10,340	14,000	17,680
9.0	2,067	3,820	7,680	11,780	15,850	19,970
8.0	1,853	4,210	8,450	12,880	17,370	21,840
7.0	1,625	4,520	9,010	13,700	18,590	23,280
6.0	1,385	4,790	9,510	14,460	19,490	24,360
5.0	1,135	5,070	10,140	15,380	20,580	25,790
4.0	870	5,350	10,760	16,260	21,750	27,240

Description		Assembly Order No.
Style 29	Ribbed neck aluminum bead rings (equal spacing), 1 7/8 bolts, nuts, washers	W01-358-7203
Two Ply Bellows	Ribbed neck aluminum bead rings (unequal spacing) 1 7/8 b,n,w	W01-358-7205
	Ribbed neck aluminum bead rings (equal spacing) 1 1/4 b,n,w	W01-358-7201
	Rolled plate assembly*, 1/2 blind nuts 3/4 NPT	W01-358-7275
	Rubber bellows only	W01-358-7902
Assembly weight .....		28.8 lbs
Force to collapse to minimum height (@ 0 PSIG)...		70 lbs.

Style 207	Ribbed neck aluminum bead rings (equal spacing), 1 7/8 bolts, nuts, washers	W01-358-7242
High Strength Bellows	Ribbed neck aluminum bead rings (unequal spacing) 1 7/8 b,n,w	W01-358-7239
	Rubber bellows only	W01-139-0207

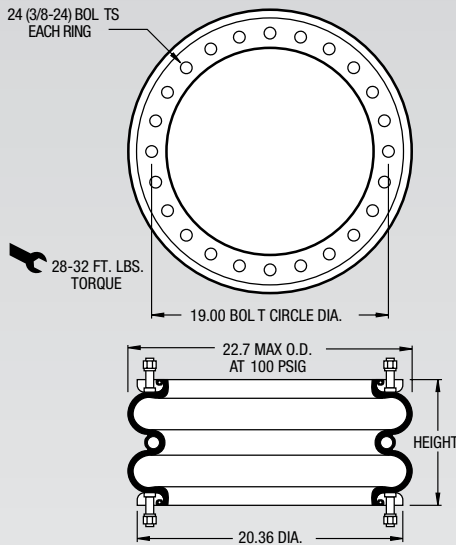

**NOTE:** A bead ring part is shown. This part is also available with rolled plates. See page 11 for explanation

\*Increase the minimum height by .70 inch. Add .70 inch to the height (bottom axis) before reading loads.

Dynamic Characteristics at 9.5 in. Design Height (Required for Airmount isolator design only)				
Volume @ 100 PSIG = 2,934 in <sup>3</sup>			Natural Frequency	
Gage Pressure (PSIG)	Load (lbs.)	Spring Rate (lbs./in.)	CPM	HZ
40	9,780	2,752	96	1.60
60	14,860	3,737	94	1.57
80	20,060	4,844	92	1.54
100	25,350	5,917	91	1.51

Recommended Design Position Static Pressure 0-100 psi

RECOMMENDED AIRMOUNT DESIGN HEIGHT 9.5 INCHES

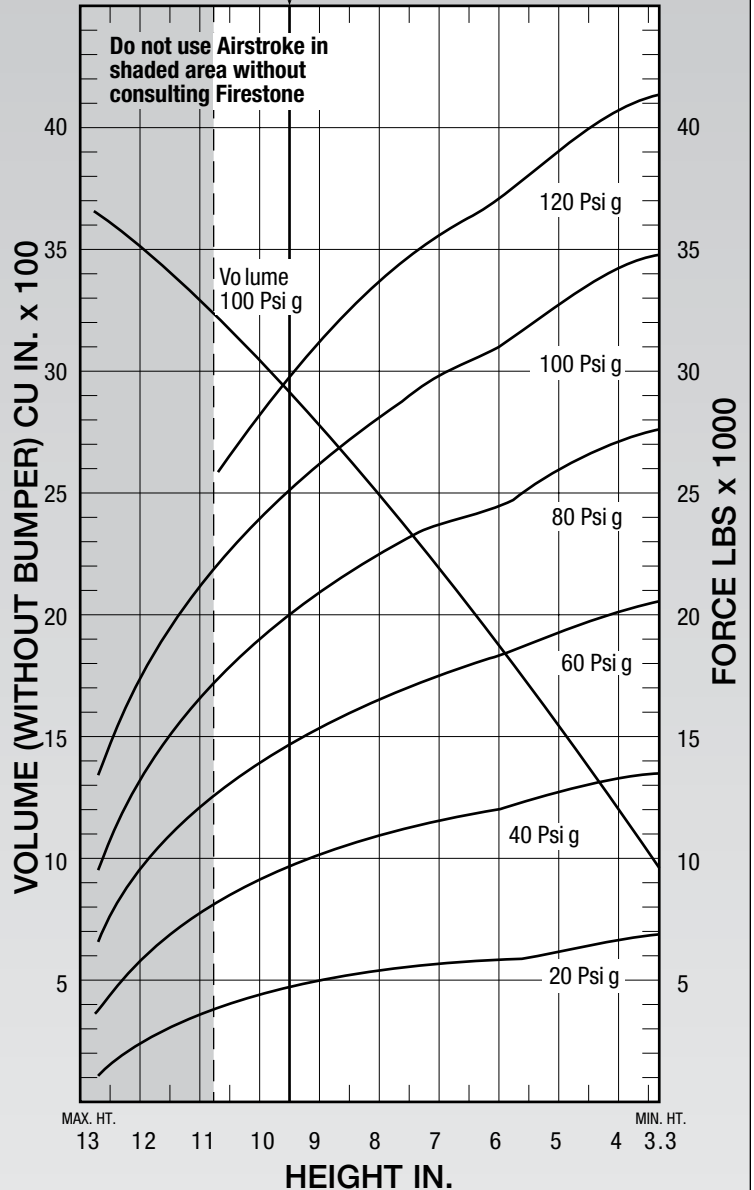

See page 12 for instructions on how to use chart.

Force Table (Use for Airstroke™ actuator design)						
Assembly Height (in.)	Volume @ 100 PSIG (in <sup>3</sup> )	Pounds Force				
		@20 PSIG	@40 PSIG	@60 PSIG	@80 PSIG	@100 PSIG
10.0	3,064	4,480	9,320	14,130	19,110	24,190
9.0	2,796	4,990	10,200	15,520	20,940	26,410
8.0	2,512	5,440	10,990	16,680	22,480	28,270
7.0	2,206	5,780	11,650	17,620	23,740	29,830
6.0	1,889	5,950	12,090	18,330	24,640	31,000
5.0	1,559	6,310	12,720	19,340	26,040	32,740
4.0	1,211	6,650	13,320	20,150	27,140	34,100



Description		Assembly Order No.
Style 200	Ribbed neck aluminum bead rings (equal spacing), 1 7/8 bolts, nuts, washers	W01-358-7772
Two Ply Bellows	Ribbed neck aluminum bead rings (equal spacing) 1 1/4 b,n,w	W01-358-7775
	Rubber bellows only	W01-358-5126
Assembly weight .....		34.9 lbs
Force to collapse to minimum height (@ 0 PSIG)		100 lbs.

Recommended Design Position Static Pressure 0-100 psi

RECOMMENDED AIRMOUNT DESIGN HEIGHT 9.5 INCHES

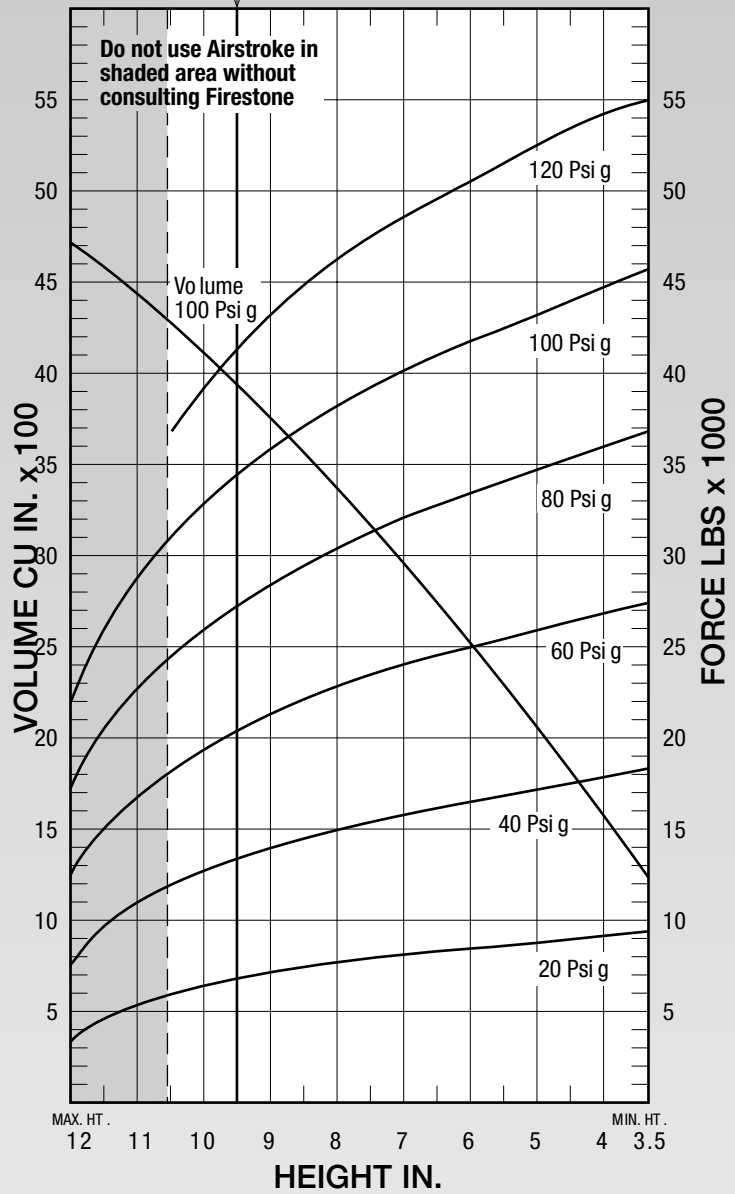
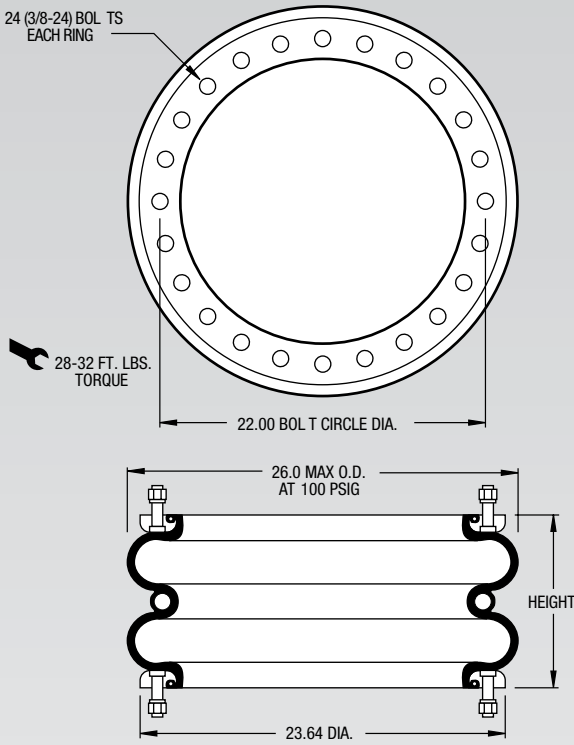

See page 12 for instructions on how to use chart.

Dynamic Characteristics at 9.5 in. Design Height (Required for Airmount isolator design only)				
Volume @ 100 PSIG = 3,921 in <sup>3</sup>			Natural Frequency	
Gage Pressure (PSIG)	Load (lbs.)	Spring Rate (lbs./in.)	CPM	HZ
40	13,290	3,784	100	1.67
60	20,390	5,336	96	1.60
80	27,330	6,763	93	1.56
100	34,620	8,105	91	1.51

Force Table (Use for Airstroke™ actuator design)						
Assembly Height (in.)	Volume @ 100 PSIG (in <sup>3</sup> )	Pounds Force				
		@20 PSIG	@40 PSIG	@60 PSIG	@80 PSIG	@100 PSIG
10.0	4,099	6,270	12,530	19,300	25,970	33,040
9.0	3,734	7,070	13,960	21,360	28,550	36,020
8.0	3,343	7,710	15,070	22,960	30,580	38,450
7.0	2,928	8,180	15,920	24,160	32,200	40,400
6.0	2,495	8,540	16,610	25,110	33,550	41,960
5.0	2,055	8,880	17,280	26,010	34,790	43,400
4.0	1,589	9,260	18,000	26,960	36,020	44,850

**NOTE: Replacement for Style 211**

Description		Assembly Order No.
Style 215	Ribbed neck aluminum bead rings (equal spacing), 1 7/8 bolts, nuts, washers	W01-358-7230
Two Ply High Strength Bellows	Ribbed neck aluminum bead rings (unequal spacing) 1 7/8 b,n,w	W01-358-7301
	Ribbed neck aluminum bead rings (equal spacing) 1 1/4 b,n,w	W01-358-7302
	Rubber bellows only	W01-358-7912
Assembly weight.....		41.0 lbs.
Force to collapse to minimum height (@ 0 PSIG)		160 lbs.

Recommended Design Position Static Pressure 0-100 psi

RECOMMENDED AIRMOUNT DESIGN HEIGHT 10.5 INCHES

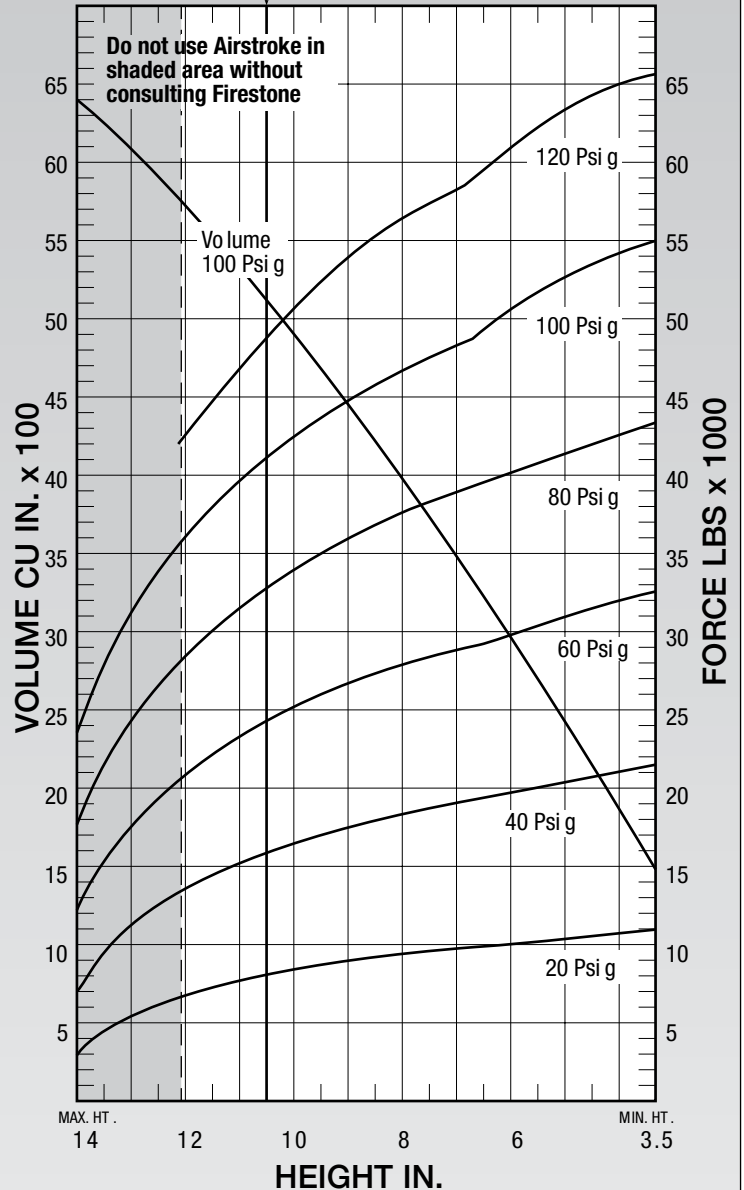
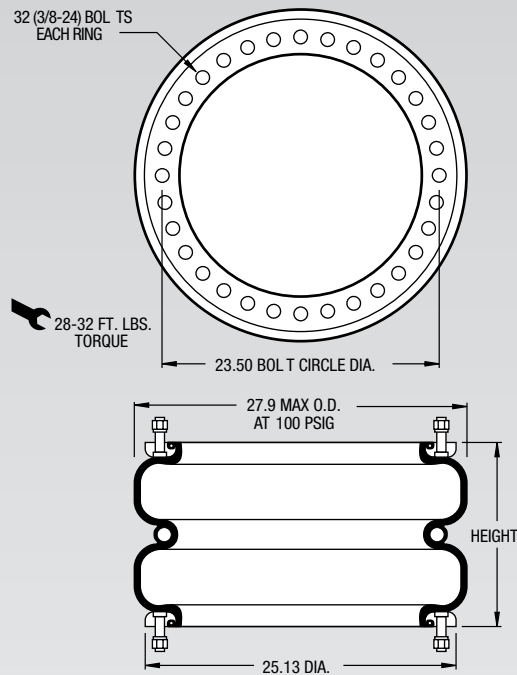

See page 12 for instructions on how to use chart.

Dynamic Characteristics at 10.5 in. Design Height (Required for Airmount isolator design only)				
Volume @ 100 PSIG = 5,094 in <sup>3</sup>			Natural Frequency	
Gage Pressure (PSIG)	Load (lbs.)	Spring Rate (lbs./in.)	CPM	HZ
40	15,840	3,858	93	1.54
60	24,140	5,370	88	1.47
80	32,550	6,857	86	1.44
100	40,980	8,203	84	1.40

Force Table (Use for Airstroke™ actuator design)						
Assembly Height (in.)	Volume @ 100 PSIG (in <sup>3</sup> )	Pounds Force				
		@20 PSIG	@40 PSIG	@60 PSIG	@80 PSIG	@100 PSIG
12.0	5,701	6,520	13,310	20,720	28,410	36,100
10.0	4,882	8,170	16,480	25,050	33,720	42,350
8.0	3,964	9,120	18,460	27,920	37,570	47,010
6.0	2,973	9,910	19,940	30,070	40,430	51,100
4.0	1,907	10,790	21,290	31,970	42,980	54,390

Description		Assembly Order No.
Style 248-2	Ribbed neck aluminum bead rings (equal spacing), 1 7/8 bolts, nuts, washers	W01-358-9602
Four Ply Bellows		
Assembly weight .....		78.6 lbs.
Force to collapse to minimum height (@ 0 PSIG)		350 lbs.

Recommended Design Position Static Pressure 0-100 psi

RECOMMENDED AIRMOUNT DESIGN HEIGHT 11.0 INCHES

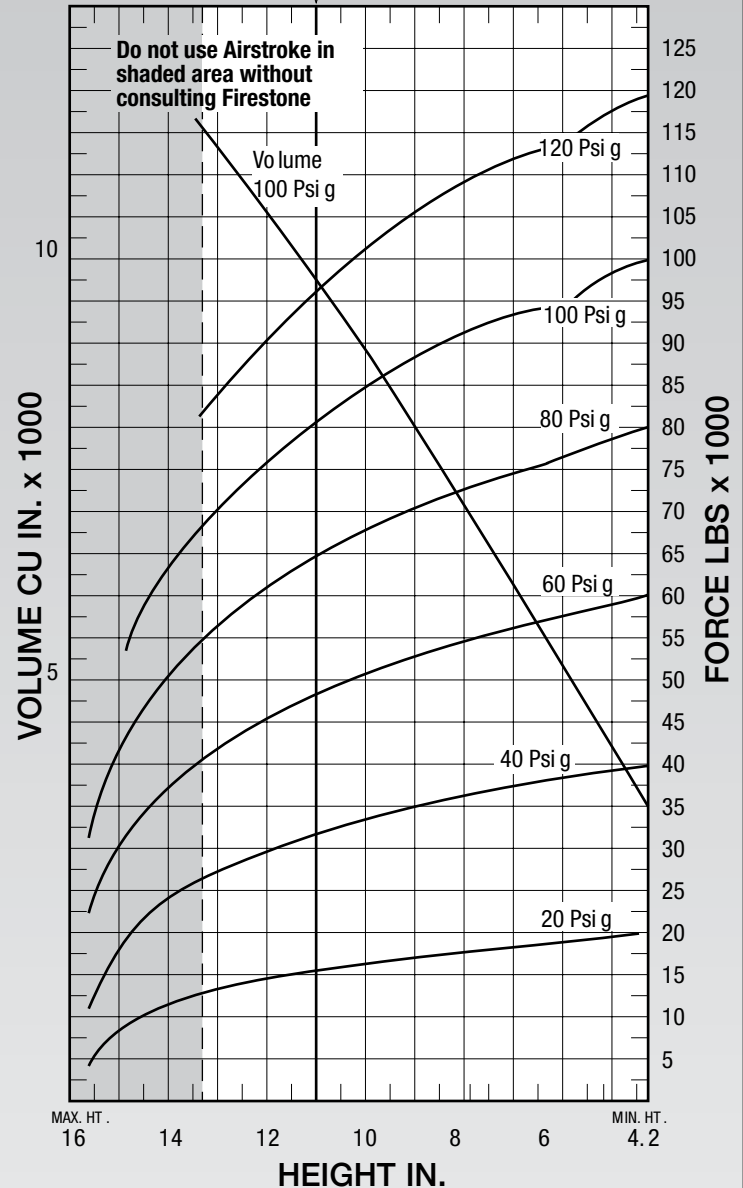
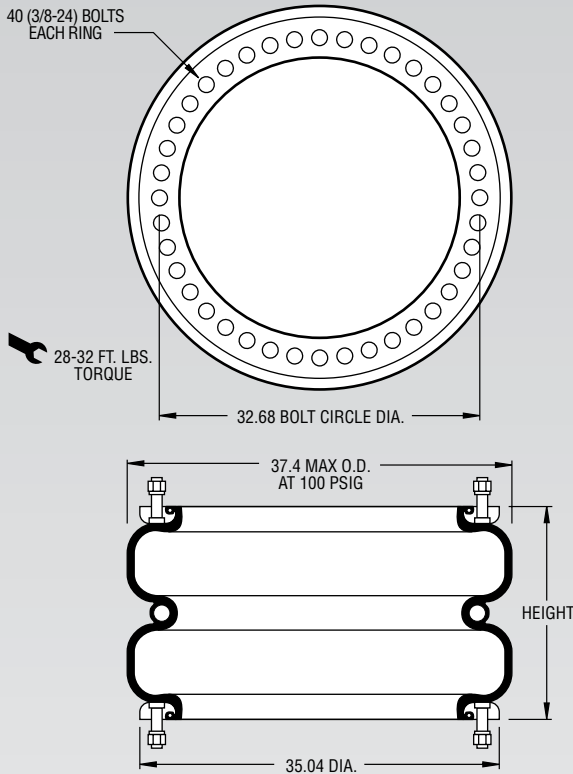

**NOTE:** The effective length of 1 7/8 bolt is 1.05" in this bead ring.

Dynamic Characteristics at 11.0 in. Design Height (Required for Airmount isolator design only)				
Volume @ 100 PSIG = 9,815 in <sup>3</sup>			Natural Frequency	
Gage Pressure (PSIG)	Load (lbs.)	Spring Rate (lbs./in.)	CPM	HZ
40	30,830	6,746	88	1.46
60	47,720	9,549	84	1.40
80	63,890	12,423	83	1.38
100	79,730	14,989	81	1.36

See page 12 for instructions on how to use chart.

Force Table (Use for Airstroke™ actuator design)						
Assembly Height (in.)	Volume @ 100 PSIG (in <sup>3</sup> )	Pounds Force				
		@20 PSIG	@40 PSIG	@60 PSIG	@80 PSIG	@100 PSIG
13.0	11,386	12,660	26,460	41,020	55,290	69,700
11.0	9,815	15,200	30,830	47,720	63,890	79,730
9.0	8,090	16,890	34,210	52,080	69,850	87,790
7.0	6,243	18,210	37,030	55,570	74,410	93,230
5.0	4,304	19,270	38,820	58,730	78,570	98,180

Description		Assembly Order No.
Style 352	Blind nuts, 1/4 NPT	W01-358-8048
	Blind nuts, 3/4 NPT	W01-358-8047
Two Ply Bellows		
Assembly weight .....		17.6 lbs.
Force to collapse to minimum height (@ 0 PSIG)		200 lbs.

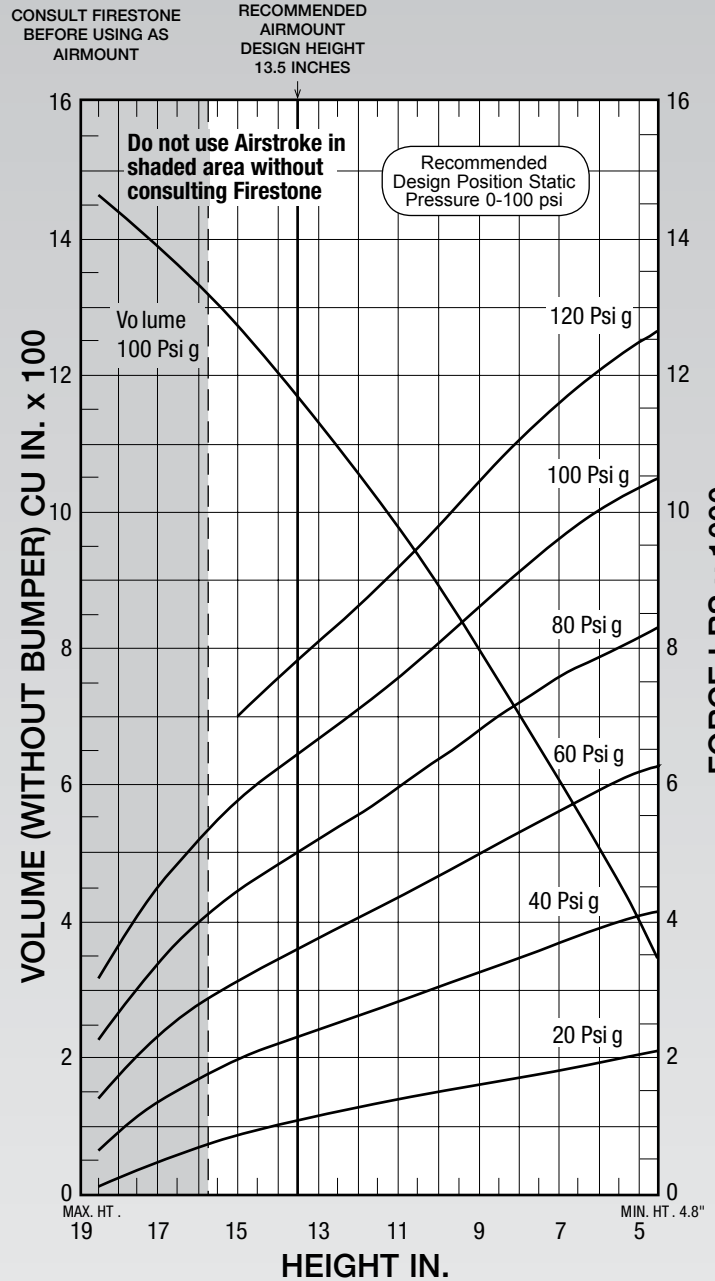
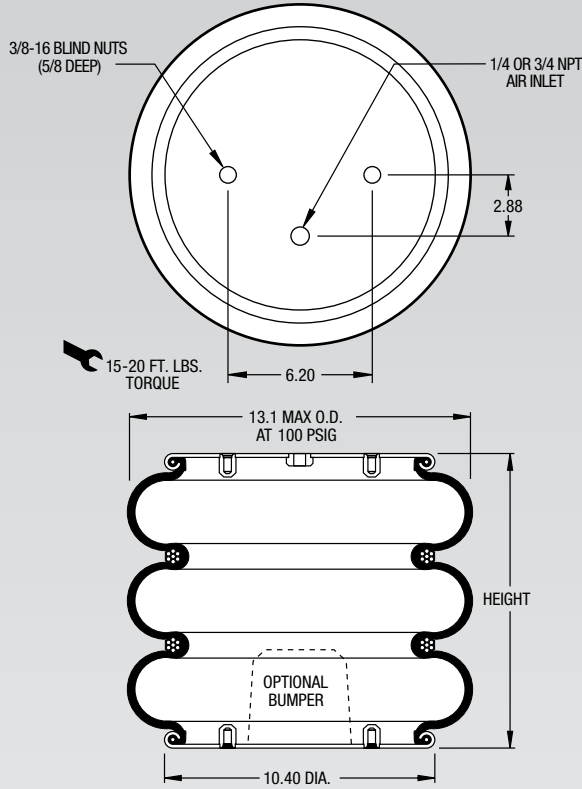

See page 12 for instructions on how to use chart.

Dynamic Characteristics at 13.5 in. Design Height (Required for Airmount isolator design only)				
Volume @ 100 PSIG = 1,168 in <sup>3</sup>			Natural Frequency	
Gage Pressure (PSIG)	Load (lbs.)	Spring Rate (lbs./in.)	CPM	HZ
40	2,319	475	85	1.42
60	3,631	675	81	1.35
80	5,017	851	77	1.29
100	6,463	1,042	75	1.26

Force Table (Use for Airstroke™ actuator design)						
Assembly Height (in.)	Volume @ 100 PSIG (in <sup>3</sup> )	Pounds Force				
		@20 PSIG	@40 PSIG	@60 PSIG	@80 PSIG	@100 PSIG
16.0	1,330	679	1,695	2,780	4,000	5,221
14.0	1,203	1,015	2,211	3,480	4,838	6,248
12.0	1,057	1,278	2,622	4,068	5,557	7,104
10.0	892	1,497	3,025	4,662	6,365	8,069
8.0	708	1,700	3,457	5,296	7,201	9,127
6.0	507	1,917	3,896	5,910	7,881	10,030
5.0	400	2,040	4,095	6,169	8,165	10,363

Description		Assembly Order No.
Style 313	Blind nuts, 1/4 NPT	W01-358-7808
	Blind nuts, 1/4 NPT, bumper	W01-358-7811
Two Ply	Blind nuts, 3/4 NPT	W01-358-7802
	Blind nuts, 3/4 NPT, bumper	W01-358-7807
Bellows	Countersunk steel bead rings, 1 <sup>3</sup> / <sub>4</sub> bolts, nuts, washers	W01-358-7801
	Rubber bellows only	W01-358-7900
Assembly weight .....		20.6 lbs
Force to collapse to minimum height (@ 0 PSIG)...		46 lbs.

Style 39	Blind nuts, 1/4 NPT	W01-358-1098
	Blind nuts, 3/4 NPT	W01-358-7815
High Strength Bellows	Countersunk steel bead rings, 1 <sup>3</sup> / <sub>4</sub> bolts, nuts, washers	W01-358-1099

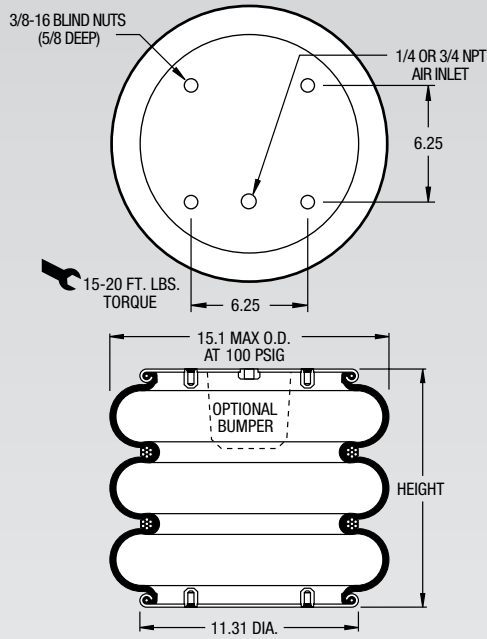

**NOTE:** A bead plate part is shown. This part is also available with bead rings. See pages 8-10 for explanation.

Dynamic Characteristics at 13.0 in. Design Height (Required for Airmount isolator design only)				
Volume @ 100 PSIG = 1,585 in <sup>3</sup>			Natural Frequency	
Gage Pressure (PSIG)	Load (lbs.)	Spring Rate (lbs./in.)	CPM	HZ
40	3,310	716	87	1.45
60	5,120	1,049	85	1.41
80	7,020	1,348	82	1.37
100	8,960	1,668	81	1.35

CONSULT FIRESTONE BEFORE USING AS AIRMOUNT

RECOMMENDED AIRMOUNT DESIGN HEIGHT 13.0 INCHES

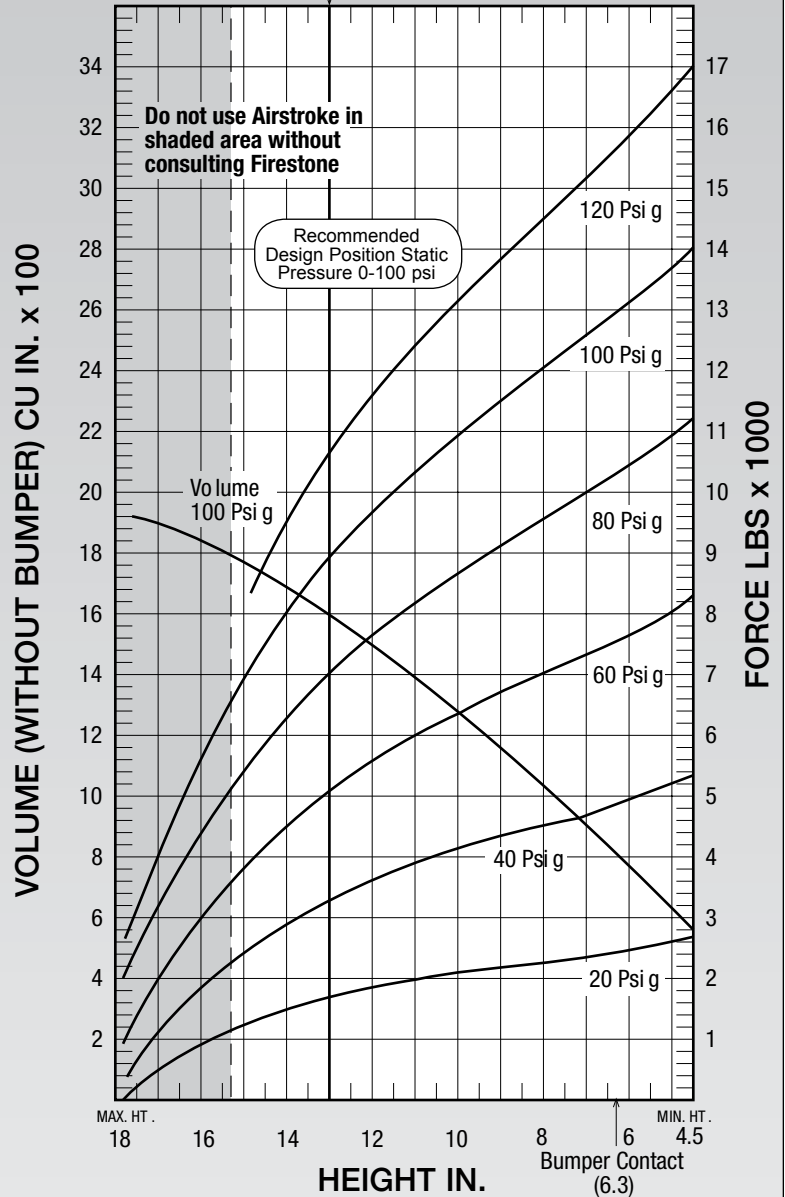

See page 12 for instructions on how to use chart.

Force Table (Use for Airstroke™ actuator design)						
Assembly Height (in.)	Volume @ 100 PSIG (in <sup>3</sup> )	Pounds Force				
		@20 PSIG	@40 PSIG	@60 PSIG	@80 PSIG	@100 PSIG
15.0	1,760	1,280	2,500	3,870	5,470	7,040
13.0	1,585	1,710	3,310	5,120	7,020	8,960
11.0	1,379	1,970	3,920	6,030	8,200	10,360
9.0	1,149	2,140	4,340	6,710	9,120	11,480
7.0	898	2,350	4,730	7,290	9,920	12,510
5.0	625	2,640	5,230	8,050	10,940	13,670

Description		Assembly Order No.
Style 333	Blind nuts, 1/4 NPT	W01-358-7845
	Blind nuts, 1/4 NPT, bumper	W01-358-7838
Two Ply Bellows	Blind nuts, 3/4 NPT	W01-358-7842
	Blind nuts, 3/4 NPT, bumper	W01-358-7849
	Countersunk steel bead ring	
	1 3/4 bolts, nuts, washers	W01-358-7830
Rubber bellows only		W01-358-7019
Assembly weight .....		26.2 lbs.
Force to collapse to minimum height (@ 0 PSIG)...		65 lbs.

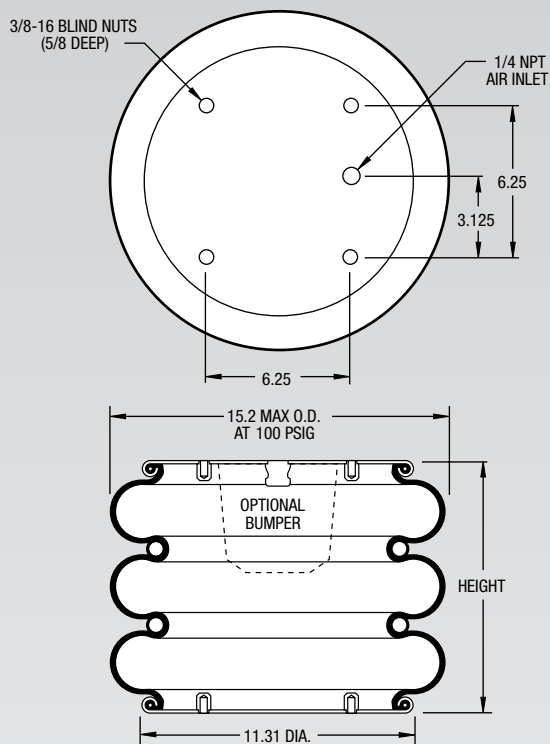

**NOTE:** A bead plate part is shown. This part is also available with bead rings. See pages 8-10 for explanation.

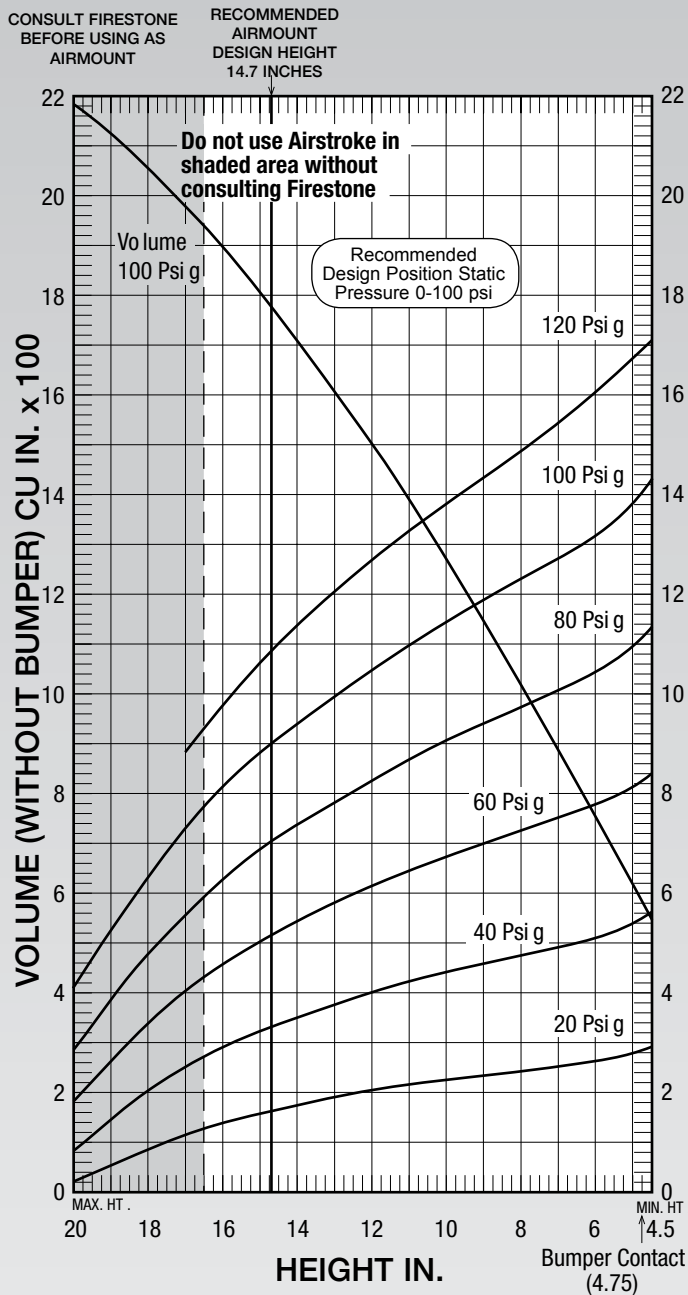

See page 12 for instructions on how to use chart.

Dynamic Characteristics at 14.70 in. Design Height (Required for Airmount isolator design only)				
Volume @ 100 PSIG = 1,786 in <sup>3</sup>			Natural Frequency	
Gage Pressure (PSIG)	Load (lbs.)	Spring Rate (lbs./in.)	CPM	HZ
40	3,282	685	86	1.43
60	5,167	933	80	1.33
80	7,000	1,179	77	1.28
100	8,940	1,425	75	1.25

Force Table (Use for Airstroke™ actuator design)						
Assembly Height (in.)	Volume @ 100 PSIG (in <sup>3</sup> )	Pounds Force				
		@20 PSIG	@40 PSIG	@60 PSIG	@80 PSIG	@100 PSIG
16.0	1,904	1,338	2,866	4,524	6,241	8,062
14.0	1,718	1,706	3,478	5,388	7,325	9,338
12.0	1,507	1,981	3,955	6,083	8,200	10,405
10.0	1,274	2,208	4,376	6,698	9,003	11,400
8.0	1,022	2,389	4,733	7,220	9,710	12,278
6.0	754	2,574	5,087	7,724	10,396	13,139
4.0	473	3,049	5,871	8,787	11,827	14,918

Description		Assembly Order No.
Style 312	Ribbed neck aluminum bead rings (equal spacing), 1 7/8 bolts, nuts, washers	W01-358-7761
Two Ply Bellows	Ribbed neck aluminum bead rings (unequal spacing) 1 7/8 b,n,w	W01-358-7760
	Rolled plate assembly*, 1/2 blind nuts, 3/4 NPT	W01-358-7286
	Rubber bellows only	W01-358-7914
Assembly weight .....		24.8 lbs
Force to collapse to minimum height (@ 0 PSIG)		135 lbs.

Style 314	Ribbed neck aluminum bead rings (equal spacing), 1 7/8 bolts, nuts, washers	W01-358-8003
High Strength Bellows	Ribbed neck aluminum bead rings (unequal spacing) 1 7/8 b,n,w	W01-358-8004
	Rubber bellows only	W01-358-7926

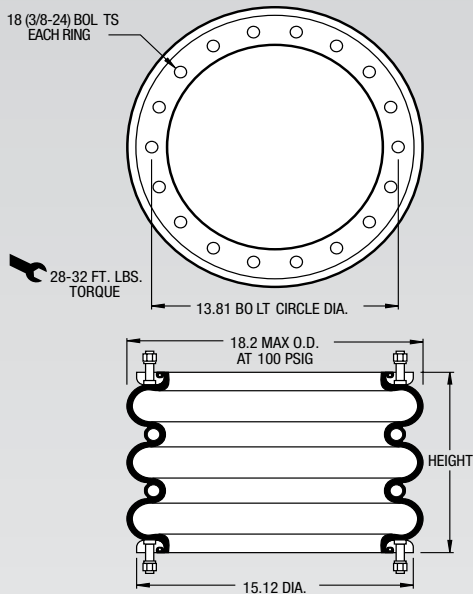

**NOTE: A bead ring part is shown. This part is also available with rolled plates. See page 11 for explanation.**

\*Increase the minimum height by .70 inch. Add .70 inch to the height (bottom axis) before reading loads.

Dynamic Characteristics at 13.0 in. Design Height (Required for Airmount isolator design only)				
Volume @ 100 PSIG = 2,207 in <sup>3</sup>			Natural Frequency	
Gage Pressure (PSIG)	Load (lbs.)	Spring Rate (lbs./in.)	CPM	HZ
40	5,100	1,056	85	1.42
60	7,930	1,536	83	1.38
80	10,730	1,950	80	1.33
100	13,530	2,371	79	1.31

CONSULT FIRESTONE BEFORE USING AS AIRMOUNT

RECOMMENDED AIRMOUNT DESIGN HEIGHT 13.0 INCHES

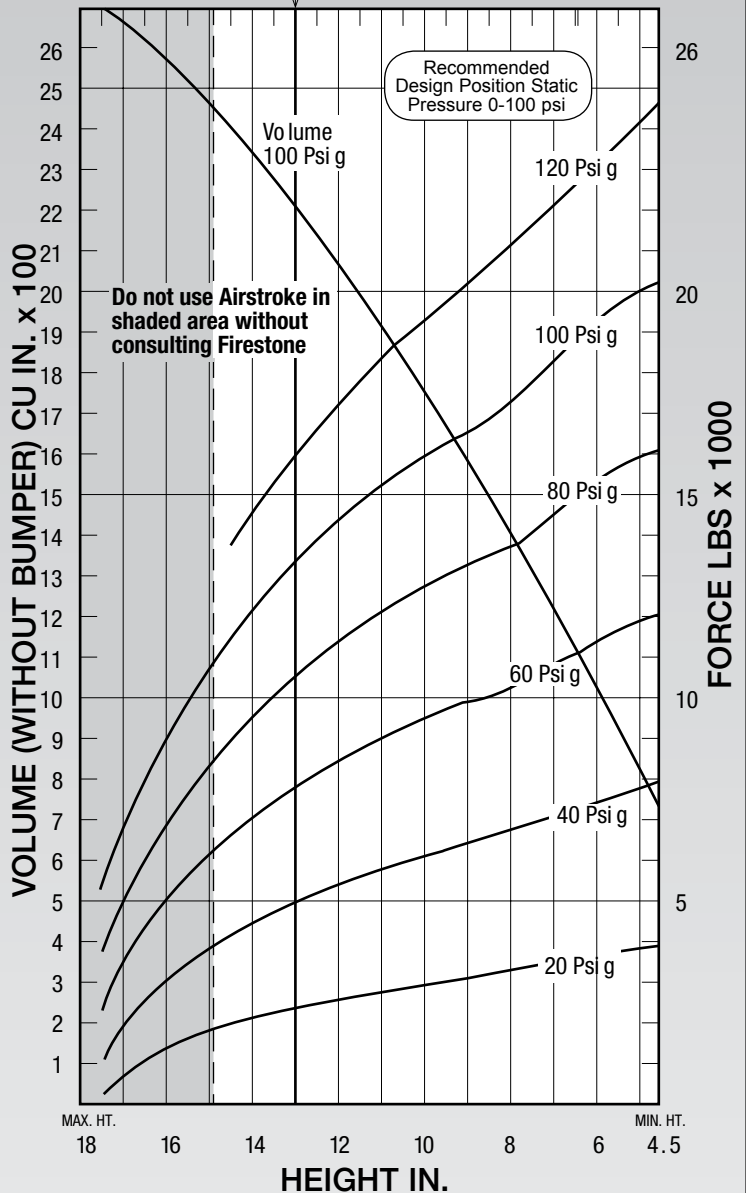

See page 12 for instructions on how to use chart.

Force Table (Use for Airstroke™ actuator design)						
Assembly Height (in.)	Volume @ 100 PSIG (in <sup>3</sup> )	Pounds Force				
		@20 PSIG	@40 PSIG	@60 PSIG	@80 PSIG	@100 PSIG
14.0	2,342	2,300	4,640	7,230	9,820	12,420
12.0	2,061	2,760	5,510	8,560	11,510	14,450
10.0	1,744	3,130	6,260	9,620	12,870	16,060
8.0	1,400	3,340	6,940	10,370	13,820	17,440
6.0	1,021	3,790	7,580	11,510	15,350	19,280

Description		Assembly Order No.
Style 323	Ribbed neck aluminum bead rings (equal spacing), 1 7/8 bolts, nuts, washers	W01-358-7823
Two Ply Bellows	Rolled plate assembly*, 1/2 blind nuts, 3/4 NPT Rubber bellows only	W01-358-7274 W01-358-7921
Assembly weight .....		34.1 lbs
Force to collapse to minimum height (@ 0 PSIG)...		70 lbs.

Style 324	Ribbed neck aluminum bead rings (equal spacing), 1 7/8 bolts, nuts, washers	W01-358-7829
High Strength Bellows	Rubber bellows only	W01-358-0324

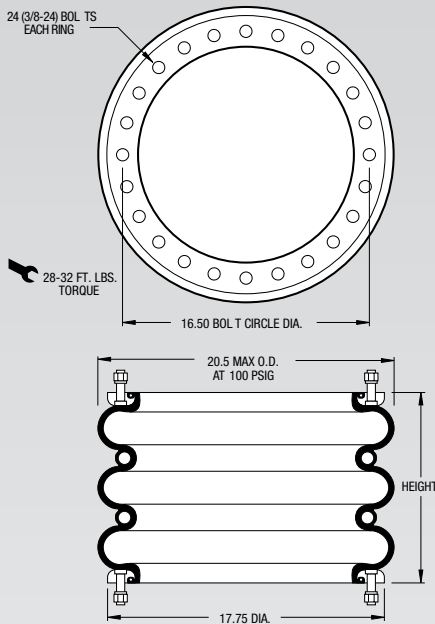

**NOTE:** A bead ring part is shown. This part is also available with rolled plates. See page 11 for explanation.

\*Increase the minimum height by .70 inch. Add .70 inch to the height (bottom axis) before reading loads.

Dynamic Characteristics at 13.0 in. Design Height (Required for Airmount isolator design only)				
Volume @ 100 PSIG = 3,073 in <sup>3</sup>			Natural Frequency	
Gage Pressure (PSIG)	Load (lbs.)	Spring Rate (lbs./in.)	CPM	HZ
40	8,010	1,744	88	1.46
60	12,030	2,104	78	1.31
80	16,270	2,784	78	1.30
100	20,580	3,624	79	1.31

CONSULT FIRESTONE BEFORE USING AS AIRMOUNT

RECOMMENDED AIRMOUNT DESIGN HEIGHT 13.0 INCHES

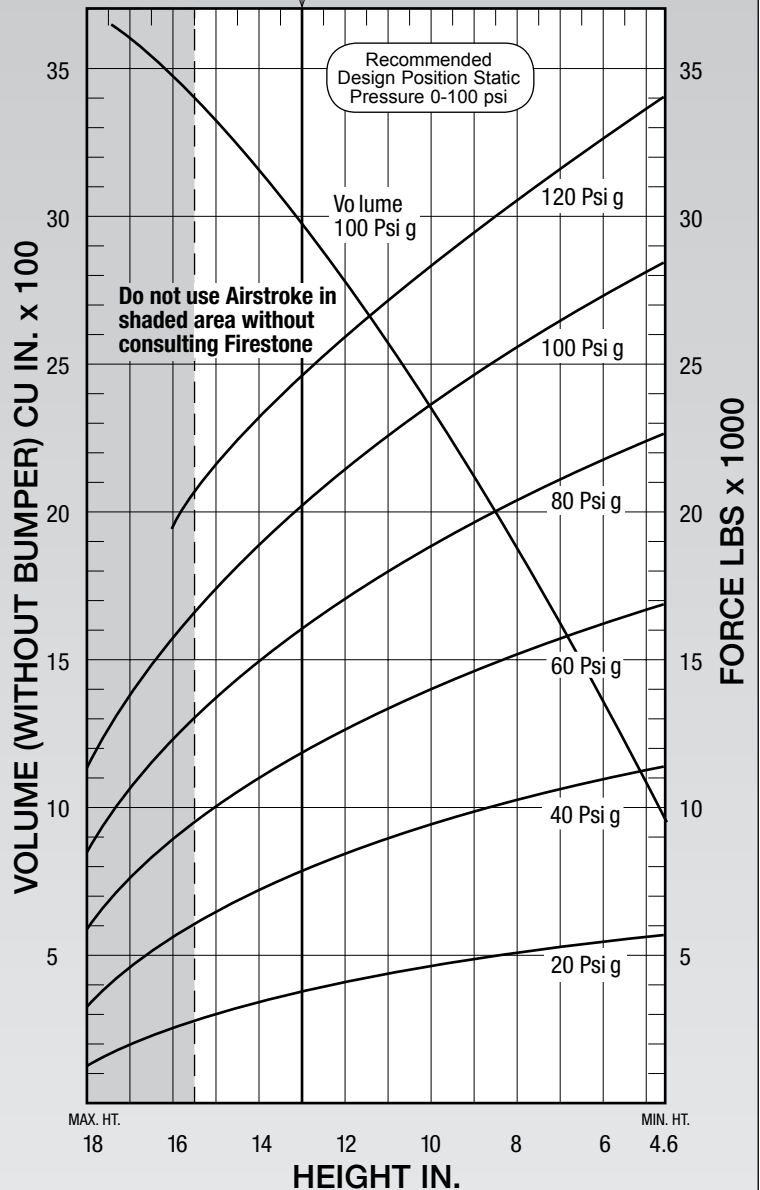

See page 12 for instructions on how to use chart.

Force Table (Use for Airstroke™ actuator design)						
Assembly Height (in.)	Volume @ 100 PSIG (in <sup>3</sup> )	Pounds Force				
		@20 PSIG	@40 PSIG	@60 PSIG	@80 PSIG	@100 PSIG
15.0	3,470	3,220	6,640	10,280	13,960	17,740
13.0	3,073	3,960	8,010	12,030	16,270	20,580
11.0	2,632	4,330	8,910	13,420	18,030	22,770
9.0	2,150	4,740	9,610	14,450	19,410	24,420
7.0	1,639	5,030	10,120	15,410	20,770	26,200
5.0	1,093	5,610	11,140	16,590	22,380	28,170



Description		Assembly Order No.
Style 320	Ribbed neck aluminum bead rings (equal spacing), 1 7/8 bolts, nuts, washers	W01-358-7324
Two Ply Bellows	Rolled plate assembly*, 1/2 blind nuts, 3/4 NPT Rubber bellows only	W01-358-7276 W01-358-0987
Assembly weight .....		39.5 lbs
Force to collapse to minimum height (@ 0 PSIG)...		90 lbs.

Style 328	Ribbed neck aluminum bead rings (equal spacing), 1 7/8 bolts, nuts, washers	W01-358-9528
High Strength Bellows	Rolled plate assembly*, 1/2 blind nuts, 3/4 NPT	W01-358-9526

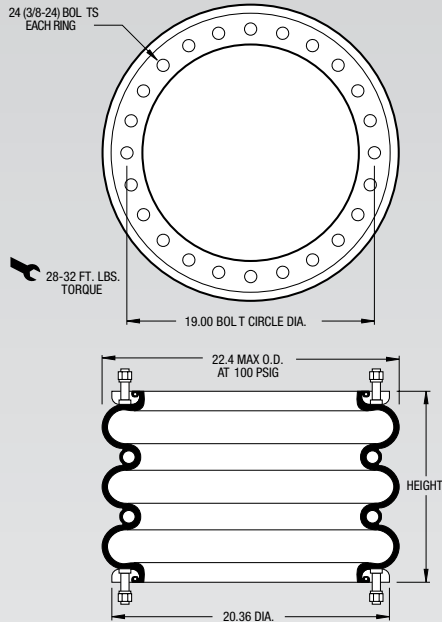

**NOTE: A bead ring part is shown. This part is also available with rolled plates. See page 11 for explanation.**

\*Increase the minimum height by .70 inch. Add .70 inch to the height (bottom axis) before reading loads.

Dynamic Characteristics at 14.0 in. Design Height (Required for Airmount isolator design only)				
Volume @ 100 PSIG = 4,263 in <sup>3</sup>			Natural Frequency	
Gage Pressure (PSIG)	Load (lbs.)	Spring Rate (lbs./in.)	CPM	HZ
40	9,340	1,588	77	1.29
60	14,250	2,515	79	1.32
80	19,200	3,114	76	1.26
100	24,220	3,724	74	1.23

CONSULT FIRESTONE BEFORE USING AS AIRMOUNT  
RECOMMENDED AIRMOUNT DESIGN HEIGHT 14.0 INCHES

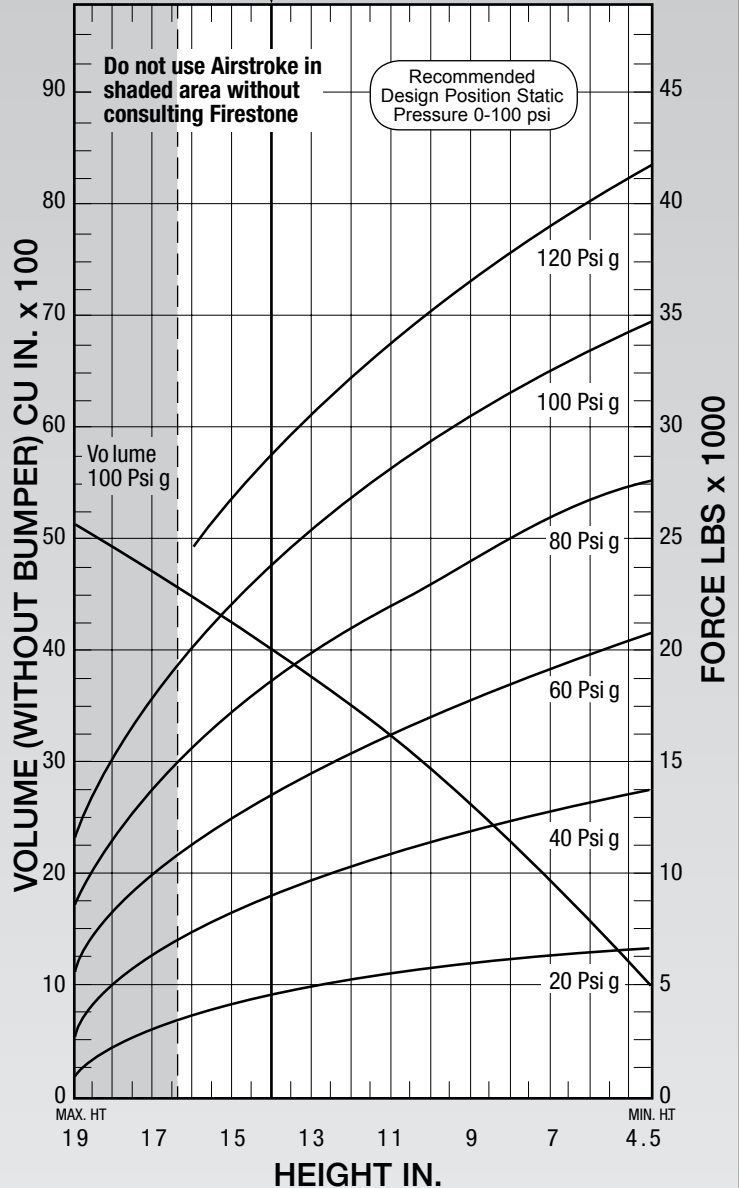

See page 12 for instructions on how to use chart.

Force Table (Use for Airstroke™ actuator design)						
Assembly Height (in.)	Volume @ 100 PSIG (in <sup>3</sup> )	Pounds Force				
		@20 PSIG	@40 PSIG	@60 PSIG	@80 PSIG	@100 PSIG
16.0	4,754	3,730	7,930	11,990	16,370	21,230
14.0	4,263	4,450	9,340	14,250	19,200	24,220
12.0	3,716	5,230	10,470	15,700	21,260	26,980
10.0	3,122	5,860	11,420	17,220	23,580	29,680
8.0	2,495	5,940	12,020	18,170	24,700	31,120
6.0	1,819	6,210	13,150	20,030	26,890	33,870

**NOTE: Replacement for Style 319**

Description		Assembly Order No.
Style 321	Ribbed neck aluminum bead rings (equal spacing), 1 7/8 bolts, nuts, washers	W01-358-7304
Two Ply High Strength Bellows	Ribbed neck aluminum bead rings (unequal spacing) 1 7/8 b,n,w	W01-358-7306
	Ribbed neck aluminum bead rings (equal spacing), 7/8 bolts, nuts, washers	W01-358-7319
	Rubber bellows only	W01-358-7919
Assembly weight .....		54.5 lbs
Force to collapse to minimum height (@ 0 PSIG)		180 lbs.

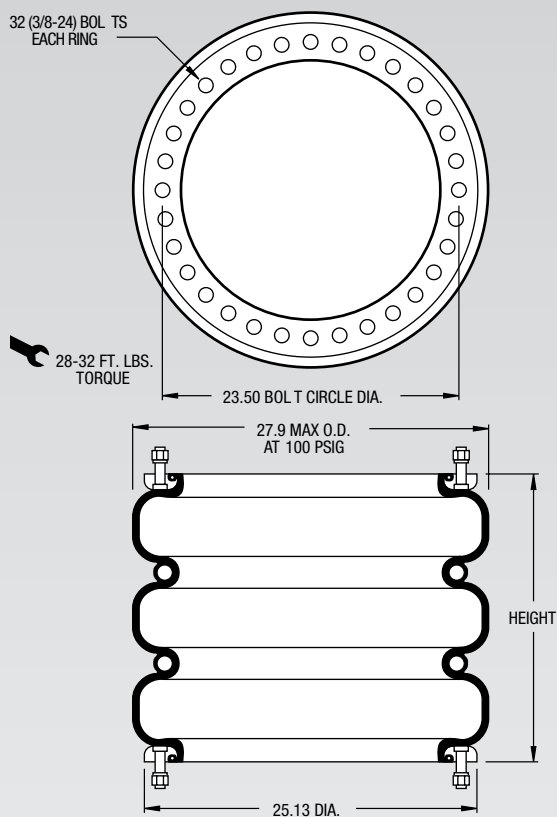

CONSULT FIRESTONE BEFORE USING AS AIRMOUNT  
RECOMMENDED AIRMOUNT DESIGN HEIGHT 15.0 INCHES

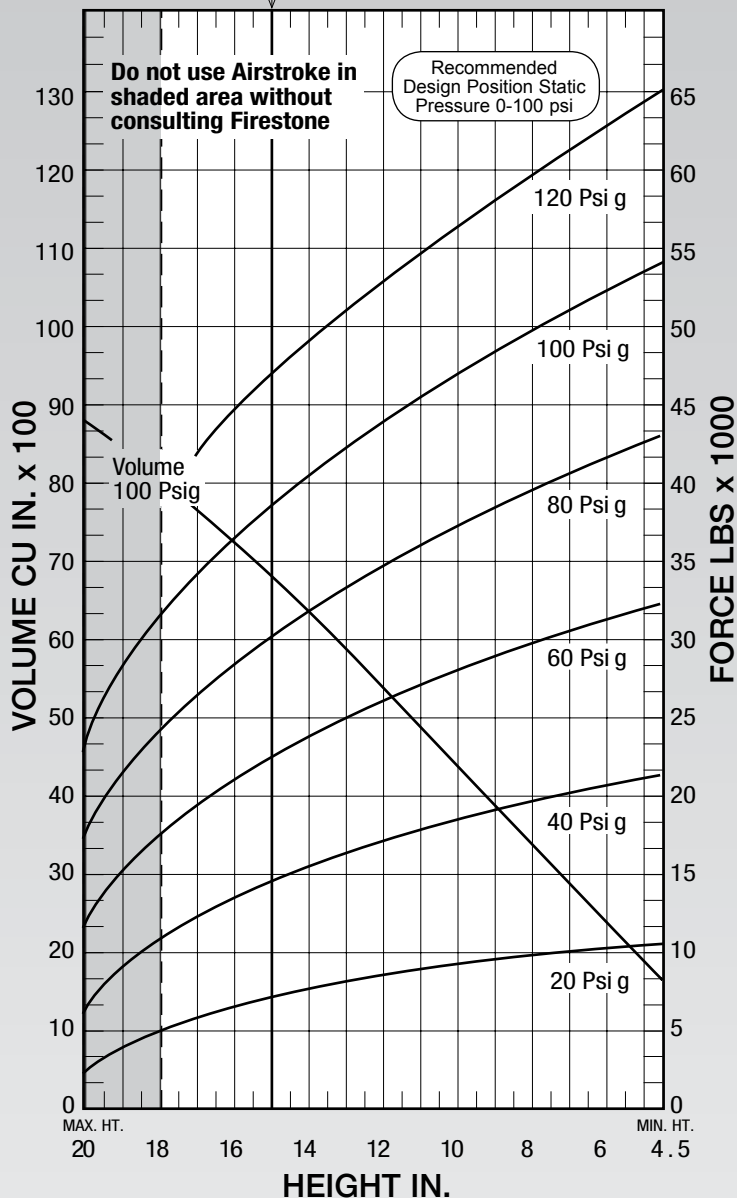

See page 12 for instructions on how to use chart.

**Dynamic Characteristics at 15.0 in. Design Height (Required for Airmount isolator design only)**

Volume @ 100 PSIG = 6,984 in <sup>3</sup>			Natural Frequency	
Gage Pressure (PSIG)	Load (lbs.)	Spring Rate (lbs./in.)	CPM	HZ
40	15,080	2,731	80	1.34
60	23,220	3,602	74	1.23
80	31,160	4,554	72	1.20
100	39,070	5,532	71	1.18

**Force Table (Use for Airstroke™ actuator design)**

Assembly Height (in.)	Volume @ 100 PSIG (in <sup>3</sup> )	Pounds Force				
		@20 PSIG	@40 PSIG	@60 PSIG	@80 PSIG	@100 PSIG
18.0	8,136	5,300	11,230	17,840	24,760	31,660
16.0	7,390	6,830	13,920	21,490	29,220	37,010
14.0	6,560	7,830	15,890	24,130	32,390	40,830
12.0	5,660	8,230	17,080	25,960	34,870	44,060
10.0	4,711	8,950	18,220	27,640	36,450	46,370
8.0	3,717	9,250	19,030	29,160	39,320	49,270
6.0	2,653	10,100	20,350	31,200	41,890	52,170

Description		Assembly Order No.
Style 348-3	Ribbed neck aluminum bead rings (equal spacing), 1 7/8 bolts, nuts, washers	W01-358-9603
High Strength Bellows	Rubber bellows only	W01-358-1023
Assembly weight .....		102.5 lbs
Force to collapse to minimum height (@ 0 PSIG)		380 lbs.

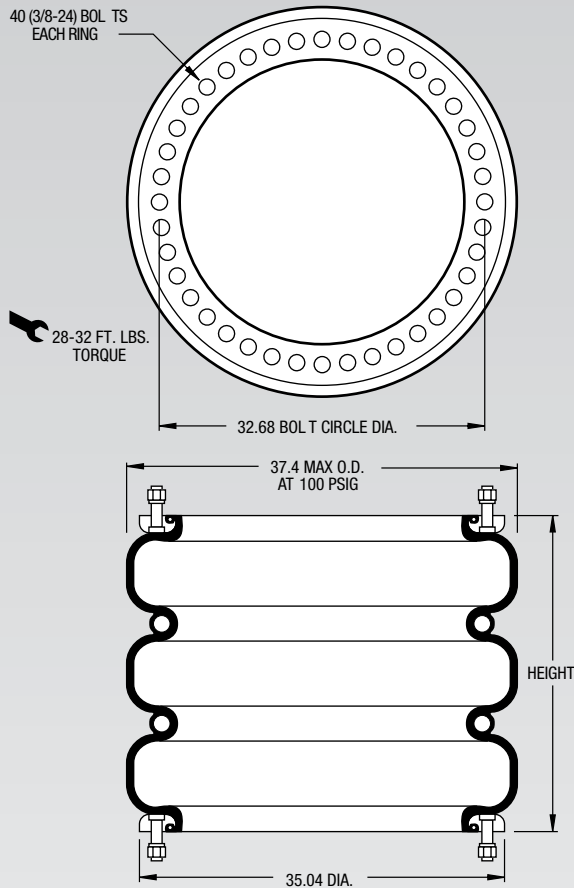

**NOTE:** The effective length of the 1 7/8 bolt is 1.05" in this bead ring.

Dynamic Characteristics at 15.0 in. Design Height (Required for Airmount isolator design only)				
Volume @ 100 PSIG = 13,501 in <sup>3</sup>			Natural Frequency	
Gage Pressure (PSIG)	Load (lbs.)	Spring Rate (lbs./in.)	CPM	HZ
40	31,480	4,761	73	1.22
60	47,870	6,586	70	1.16
80	64,870	8,614	68	1.14
100	82,540	10,592	67	1.12

CONSULT FIRESTONE BEFORE USING AS AIRMOUNT

RECOMMENDED AIRMOUNT DESIGN HEIGHT 15.0 INCHES

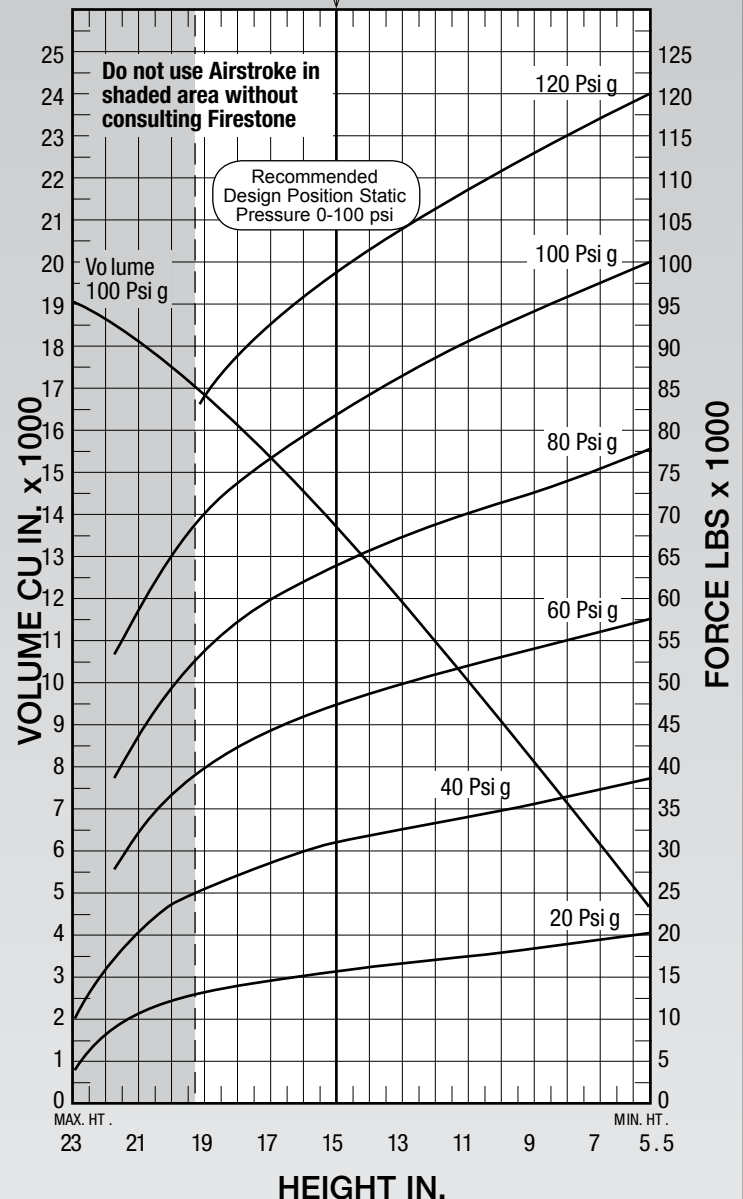

See page 12 for instructions on how to use chart.

Force Table (Use for Airstroke™ actuator design)						
Assembly Height (in.)	Volume @ 100 PSIG (in <sup>3</sup> )	Pounds Force				
		@20 PSIG	@40 PSIG	@60 PSIG	@80 PSIG	@100 PSIG
18.0	15,946	14,080	27,430	43,790	57,710	74,670
16.0	14,340	15,190	30,370	46,420	62,810	80,190
14.0	12,634	16,230	32,380	49,170	66,610	84,820
12.0	10,843	17,330	33,880	51,470	69,410	89,150
10.0	8,984	18,290	35,370	53,580	71,930	93,030
8.0	7,075	19,070	36,970	55,590	74,740	96,470
6.0	5,102	19,760	38,620	57,550	77,790	99,680

Description		Assembly Order No.
Style 4004	Blind nut, 1/8 NPT	W02-358-4004
Two Ply Bellows		
Assembly weight ..... .7 lbs.		

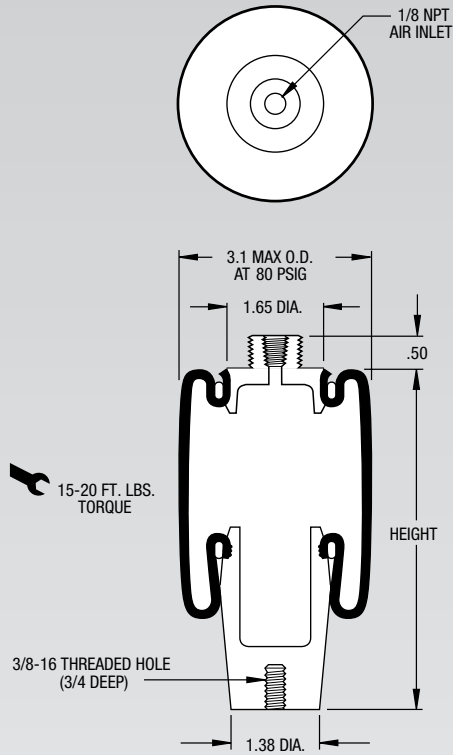

**NOTE:** Bellows will not compress properly with less than 10 PSIG internal pressure.

CONSULT FIRESTONE BEFORE USING AS AIRMOUNT

RECOMMENDED AIRMOUNT DESIGN HEIGHT 5.5 INCHES

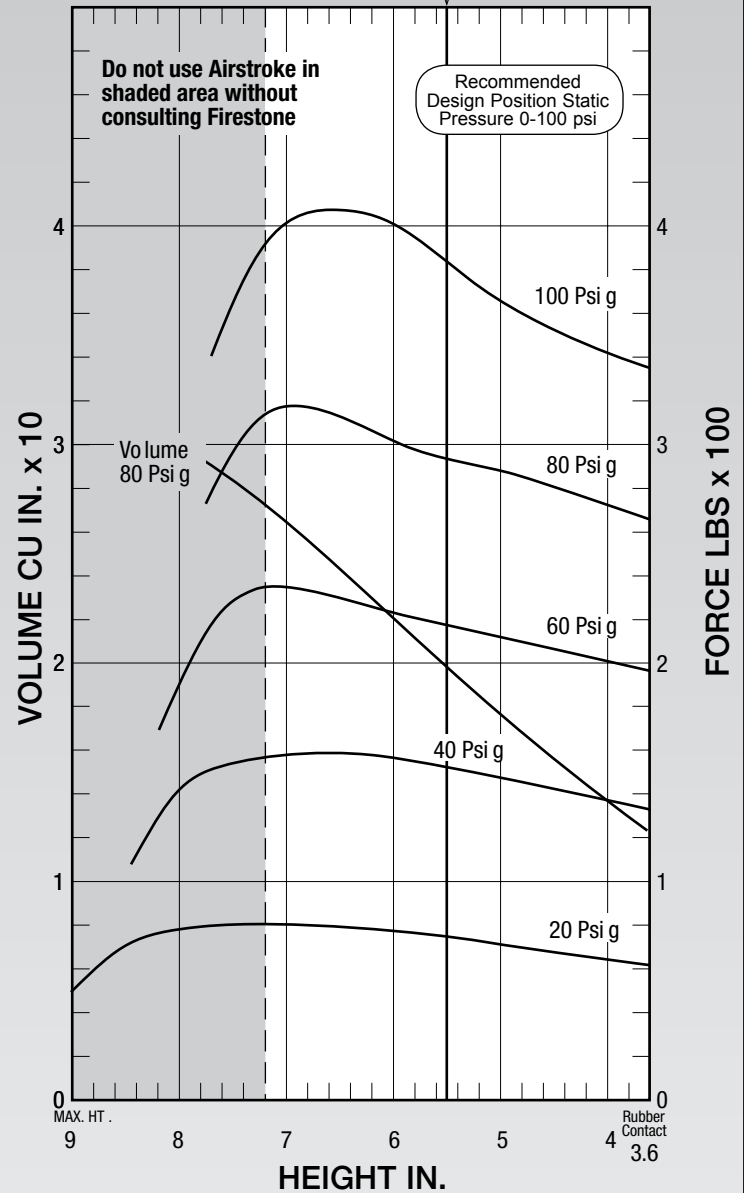

See page 12 for instructions on how to use chart.

Dynamic Characteristics at 5.5 in. Design Height (Required for Airmount isolator design only)				
Volume @ 80 PSIG = 20 in <sup>3</sup>			Natural Frequency	
Gage Pressure (PSIG)	Load (lbs.)	Spring Rate (lbs./in.)	CPM	HZ
40	150	55	113	1.88
60	220	70	107	1.78
80	290	91	105	1.74
100	380	99	95	1.59

Force Table (Use for Airstroke™ actuator design)						
Assembly Height (in.)	Volume @ 80 PSIG (in <sup>3</sup> )	Pounds Force				
		@20 PSIG	@40 PSIG	@60 PSIG	@80 PSIG	@100 PSIG
7.0	26	80	160	230	320	410
6.0	22	80	160	220	300	400
5.0	18	70	150	210	290	370
4.0	14	60	140	200	270	340

Description		Assembly Order No.
Style 7002	Blind nut, 1/8 NPT	W02-358-7002
Two Ply Bellows		
Assembly weight .....		1.0 lb.

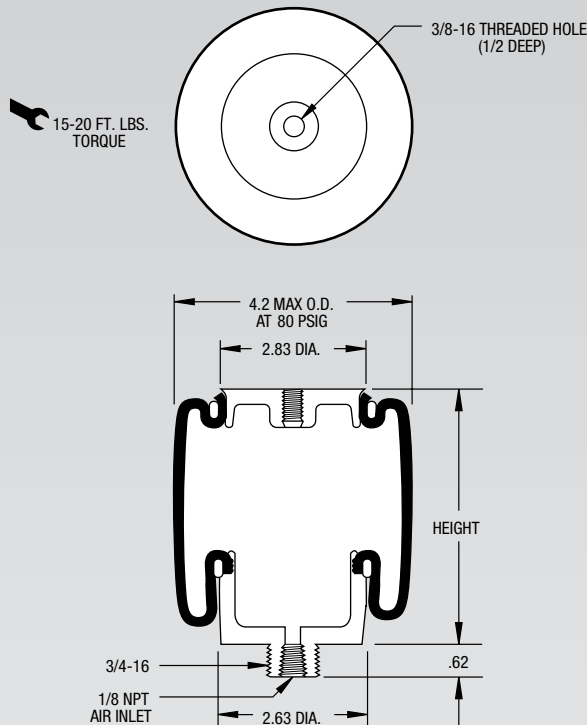

**NOTE:** Bellows will not compress properly with less than 10 PSIG internal pressure.

CONSULT FIRESTONE BEFORE USING AS AIRMOUNT

RECOMMENDED AIRMOUNT DESIGN HEIGHT 4.5 INCHES

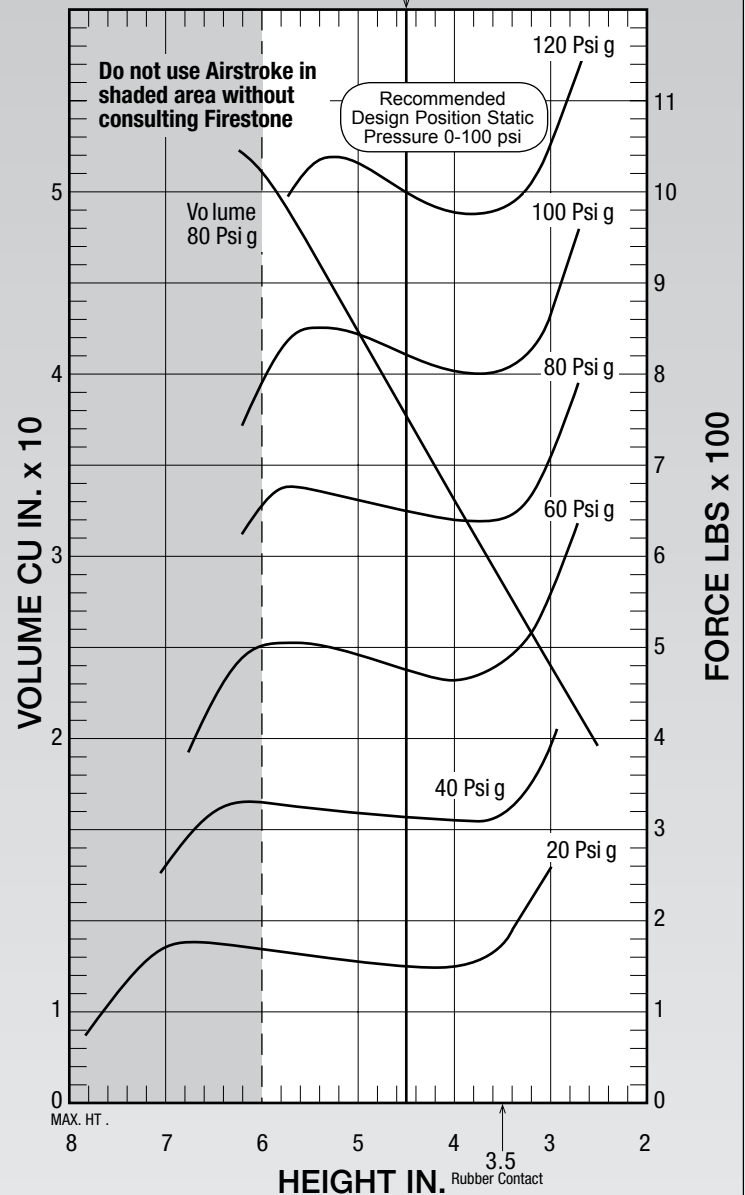

See page 12 for instructions on how to use chart.

Dynamic Characteristics at 4.5 in. Design Height (Required for Airmount isolator design only)				
Volume @ 80 PSIG = 37 in <sup>3</sup>			Natural Frequency	
Gage Pressure (PSIG)	Load (lbs.)	Spring Rate (lbs./in.)	CPM	HZ
40	310	137	124	2.07
60	480	178	114	1.91
80	650	239	114	1.89
100	820	280	110	1.81

Force Table (Use for Airstroke™ actuator design)						
Assembly Height (in.)	Volume @ 80 PSIG (in <sup>3</sup> )	Pounds Force				
		@20 PSIG	@40 PSIG	@60 PSIG	@80 PSIG	@100 PSIG
6.0	50	170	330	510	680	860
5.0	42	150	320	490	660	840
4.0	33	150	310	470	640	800

# 7010

# Firestone

# AIRSTROKE™

ACTUATORS

# AIRMOUNT™

ISOLATORS

Description		Assembly Order No.
Style 7010	Blind nut, 1/8 NPT	W02-358-7010
Two Ply Bellows		
Assembly weight .....		1.6 lbs.

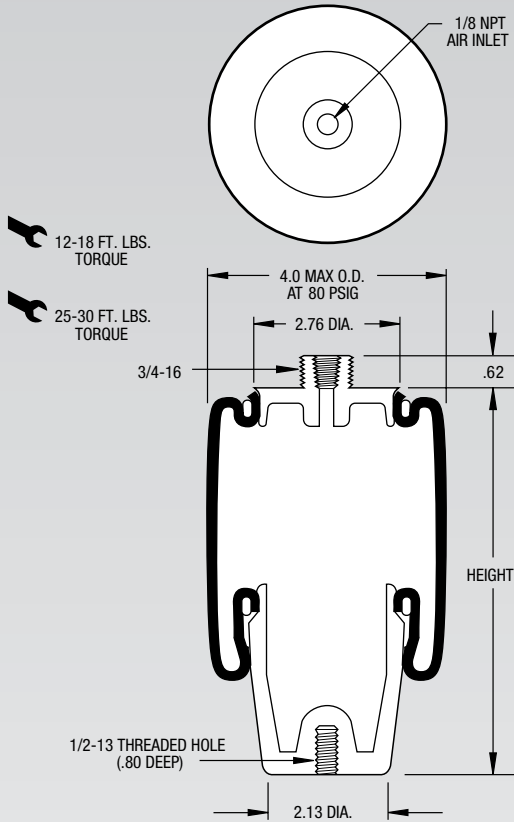

**NOTE:** Bellows will not compress properly with less than 10 PSIG internal pressure.

CONSULT FIRESTONE BEFORE USING AS AIRMOUNT

RECOMMENDED AIRMOUNT DESIGN HEIGHT 8.0 INCHES

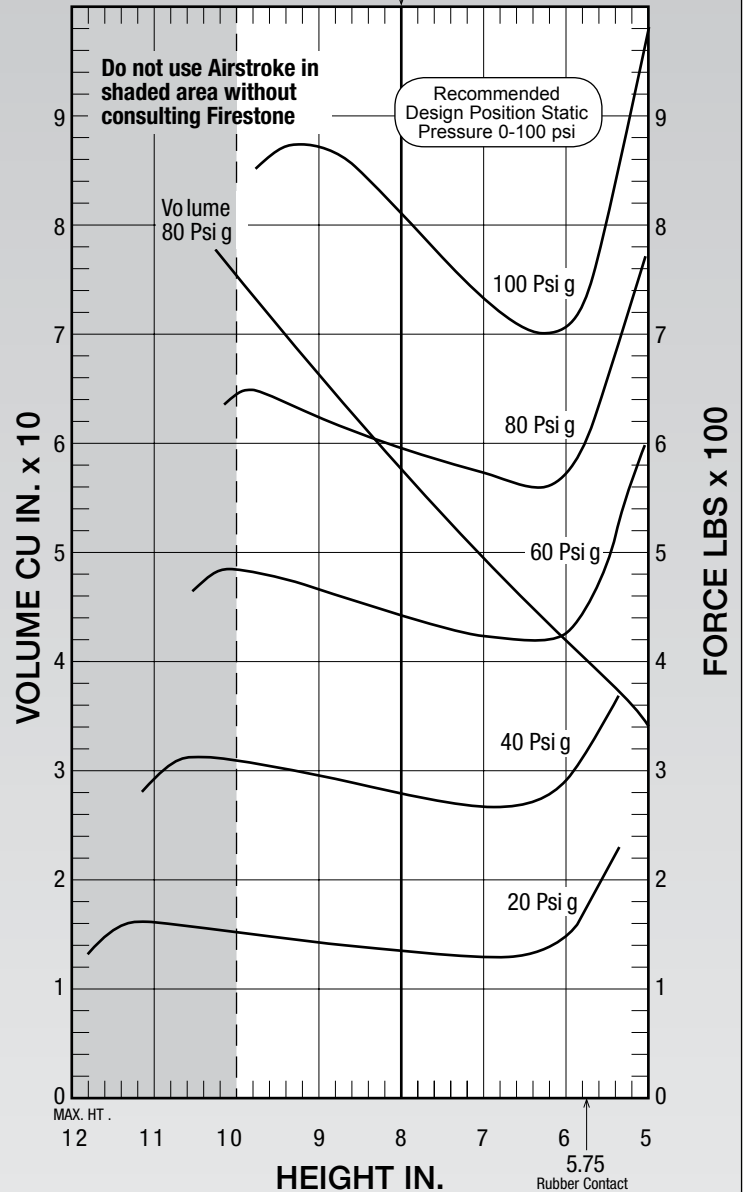

See page 12 for instructions on how to use chart.

Dynamic Characteristics at 8.0 in. Design Height (Required for Airmount isolator design only)				
Volume @ 80 PSIG = 58 in <sup>3</sup>			Natural Frequency	
Gage Pressure (PSIG)	Load (lbs.)	Spring Rate (lbs./in.)	CPM	HZ
40	280	62	88	1.47
60	440	89	84	1.40
80	600	116	83	1.38
100	810	107	68	1.13

Force Table (Use for Airstroke™ actuator design)						
Assembly Height (in.)	Volume @ 80 PSIG (in <sup>3</sup> )	Pounds Force				
		@20 PSIG	@40 PSIG	@60 PSIG	@80 PSIG	@100 PSIG
10.0	75	150	310	480	650	880
9.0	67	140	300	470	630	870
8.0	58	140	280	440	600	810
7.0	50	130	270	430	580	740

Description		Assembly Order No.
Style 7012	Blind nut, 1/8 NPT	W02-358-7012
Two Ply Bellows		
Assembly weight .....		1.8 lbs.

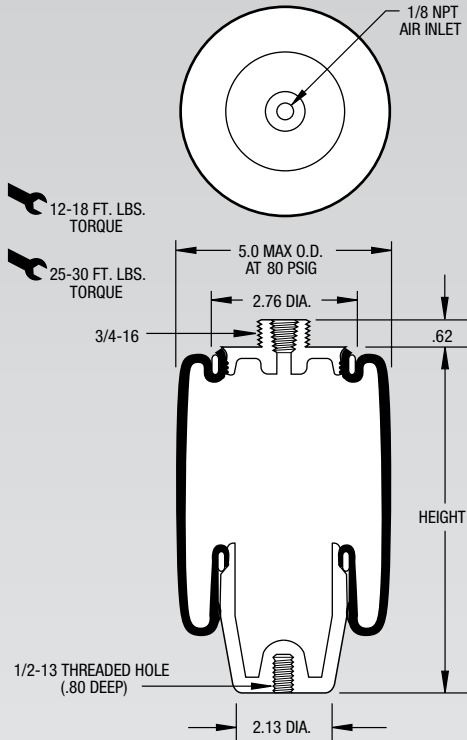

**NOTE:** Bellows will not compress properly with less than 10 PSIG internal pressure.

CONSULT FIRESTONE BEFORE USING AS AIRMOUNT

RECOMMENDED AIRMOUNT DESIGN HEIGHT 8.5 INCHES

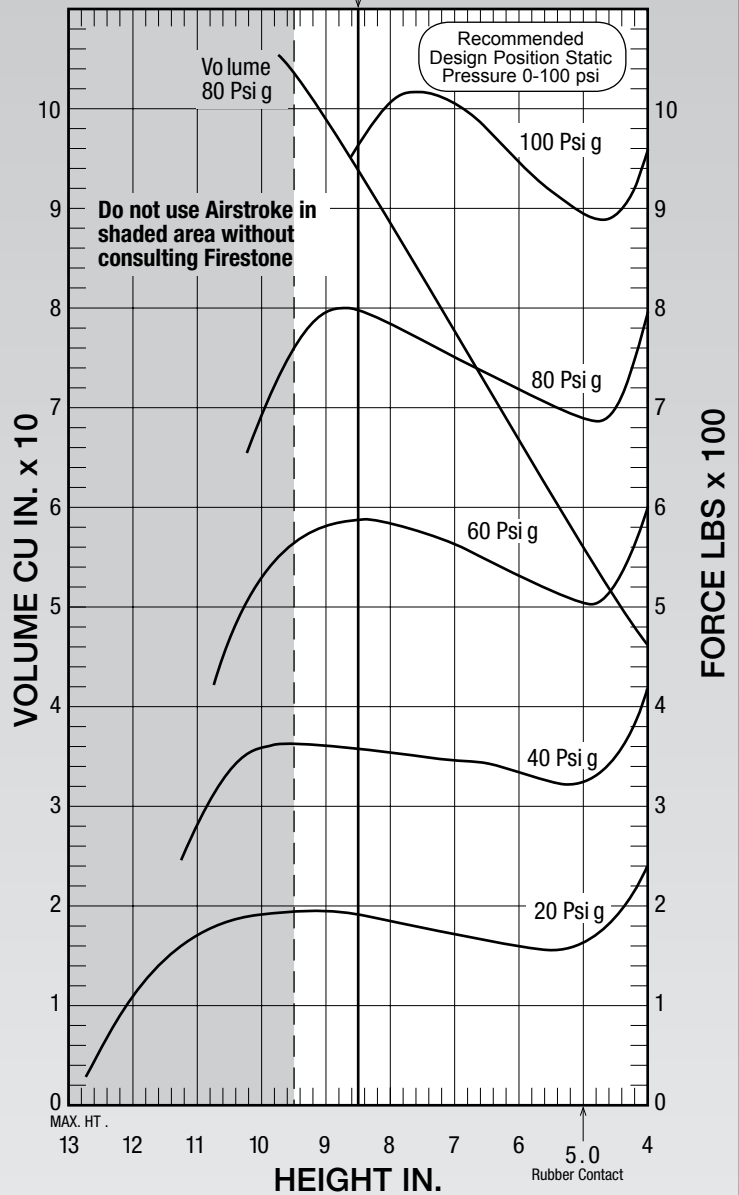

See page 12 for instructions on how to use chart.

Dynamic Characteristics at 8.5 in. Design Height (Required for Airmount isolator design only)				
Volume @ 80 PSIG = 93 in <sup>3</sup>			Natural Frequency	
Gage Pressure (PSIG)	Load (lbs.)	Spring Rate (lbs./in.)	CPM	HZ
40	360	69	82	1.37
60	590	115	83	1.38
80	800	131	76	1.27
100	1,000	184	80	1.34

Force Table (Use for Airstroke™ actuator design)						
Assembly Height (in.)	Volume @ 80 PSIG (in <sup>3</sup> )	Pounds Force				
		@20 PSIG	@40 PSIG	@60 PSIG	@80 PSIG	@100 PSIG
9.0	98	200	370	590	800	1,020
8.0	87	190	360	590	780	1,020
7.0	76	170	350	560	750	1,000
6.0	66	160	340	530	720	950
5.0	56	170	330	510	690	890

Description		Assembly Order No.
Style 110/70	Blind nut, 1/4 NPT	W26-358-9025
Two Ply Bellows		
Assembly weight .....		1.5 lbs.

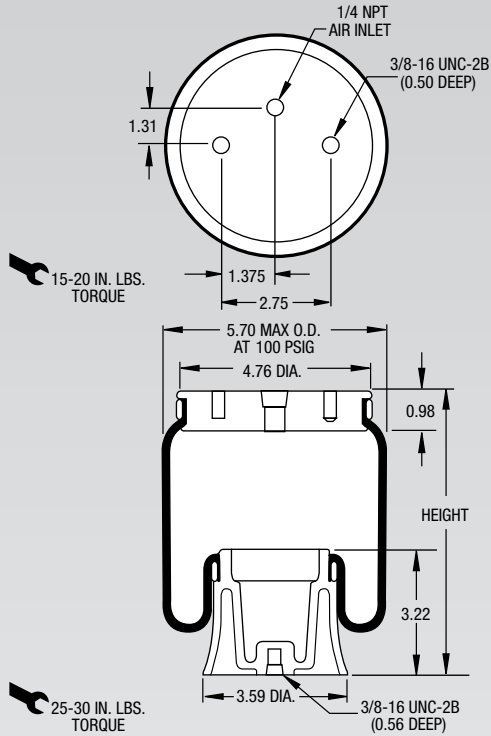

**NOTE:** Recommended operating pressure not to exceed 100 psig.

Dynamic Characteristics at 7.25 in. Design Height (Required for Airmount isolator design only)				
Volume @ 100 PSIG = 87 in <sup>3</sup>			Natural Frequency	
Gage Pressure (PSIG)	Load (lbs.)	Spring Rate (lbs./in.)	CPM	HZ
40	430	132	104	1.73
60	670	181	98	1.63
80	910	230	94	1.57
100	1160	279	92	1.53

CONSULT FIRESTONE BEFORE USING AS AIRMOUNT

RECOMMENDED AIRMOUNT DESIGN HEIGHT 7.25 INCHES

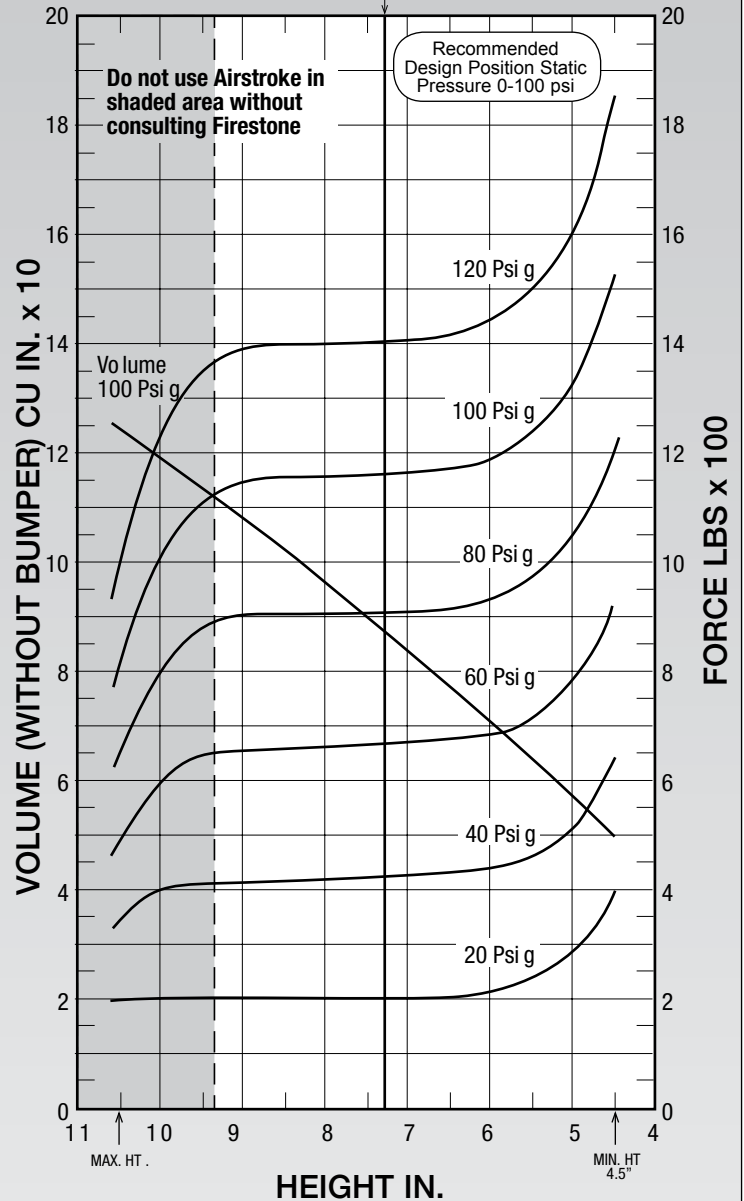

See page 12 for instructions on how to use chart.

Force Table (Use for Airstroke™ actuator design)						
Assembly Height (in.)	Volume @ 100 PSIG (in <sup>3</sup> )	Pounds Force				
		@20 PSIG	@40 PSIG	@60 PSIG	@80 PSIG	@100 PSIG
9	108	200	415	655	900	1145
8	96	200	415	655	910	1155
7	84	205	430	670	915	1160
6	71	220	445	690	935	1200
5	58	300	515	790	1050	1325



Description		Assembly Order No.
Style 1T14C-1	Blind nuts, 1/4 NPT	W01-358-5310
	Blind nuts, 1/4 NPT, bumper	W01-358-5311
Two Ply Bellows	Blind nuts, 3/4 NPT	W01-358-5305
	Blind nuts, 3/4 NPT, bumper	W01-358-5306
	Countersunk steel bead ring	
	1 3/4 bolts, nuts, washers	W01-358-5307
Assembly weight .....		6.5 lbs.

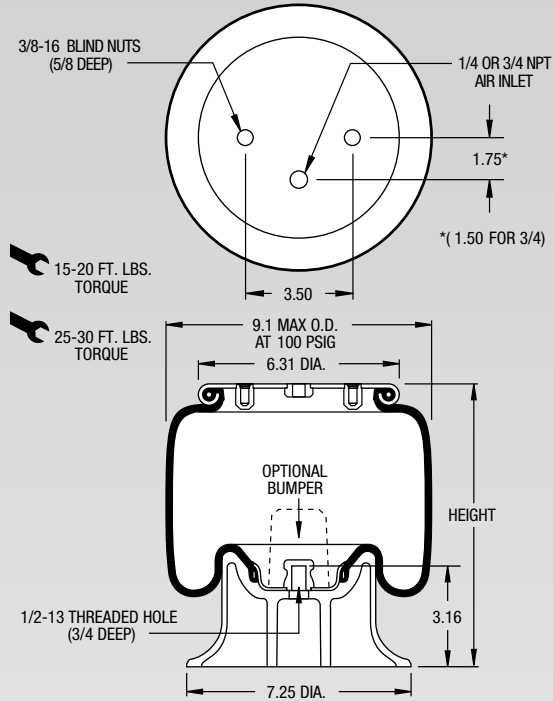

**NOTE:** Bellows will not compress properly with less than 10 PSIG internal pressure.

**NOTE:** A bead plate part is shown. This part is also available with a bead ring. Bolts are not included. See pages 8-10 for explanation.

Dynamic Characteristics at 9.0 in. Design Height (Required for Airmount isolator design only)				
Volume @ 100 PSIG = 280 in <sup>3</sup>			Natural Frequency	
Gage Pressure (PSIG)	Load (lbs.)	Spring Rate (lbs./in.)	CPM	HZ
40	1,170	250	85	1.42
60	1,890	398	86	1.44
80	2,570	535	86	1.43
100	3,240	658	85	1.41

CONSULT FIRESTONE BEFORE USING AS AIRMOUNT

RECOMMENDED AIRMOUNT DESIGN HEIGHT 9.0 INCHES

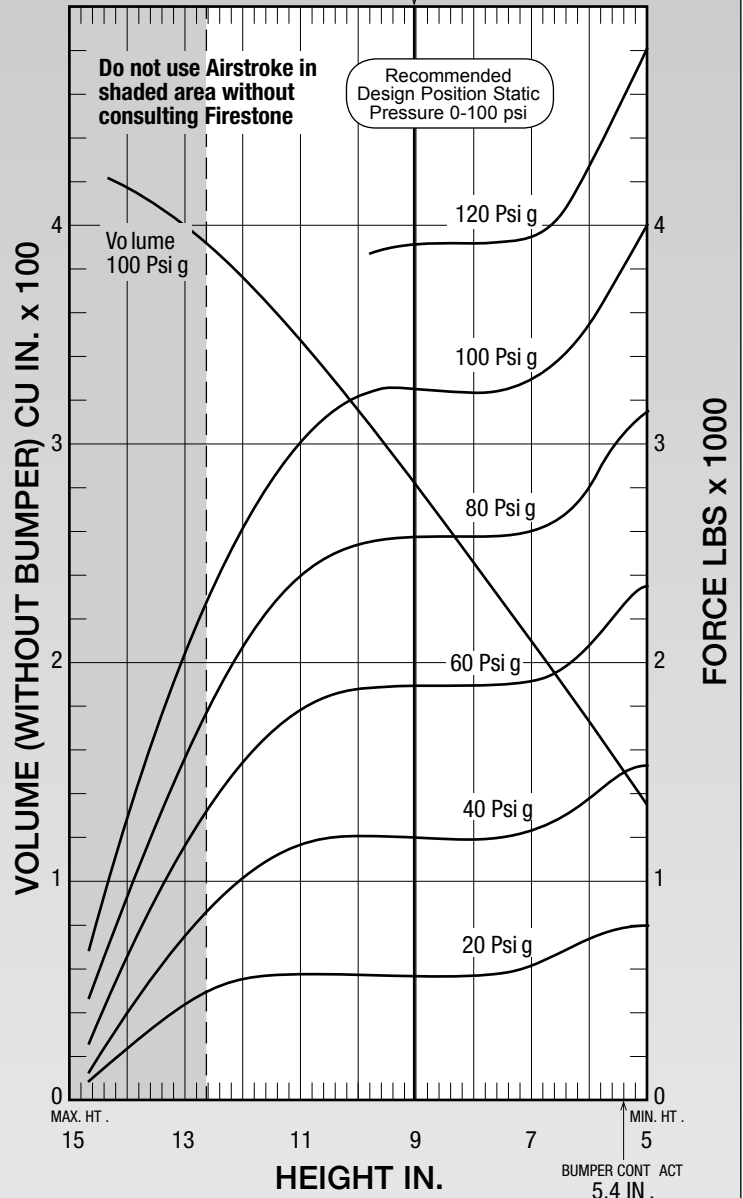

See page 12 for instructions on how to use chart.

Force Table (Use for Airstroke™ actuator design)						
Assembly Height (in.)	Volume @ 100 PSIG (in <sup>3</sup> )	Pounds Force				
		@20 PSIG	@40 PSIG	@60 PSIG	@80 PSIG	@100 PSIG
12.0	376	540	1,010	1,530	2,040	2,600
11.0	347	570	1,160	1,770	2,380	3,010
10.0	314	590	1,210	1,880	2,540	3,220
9.0	280	590	1,190	1,890	2,570	3,240
8.0	246	580	1,200	1,890	2,570	3,240
7.0	211	620	1,240	1,920	2,600	3,300
6.0	176	740	1,380	2,060	2,790	3,530

# 1T14C-3 Firestone

**AIRSTROKE**  
ACTUATORS

**AIRMOUNT**  
ISOLATORS

Description		Assembly Order No.
Style 1T14C-3	Blind nuts, 1/4 NPT	W01-358-5405
Two Ply Bellows		
Assembly weight .....		6.8 lbs.

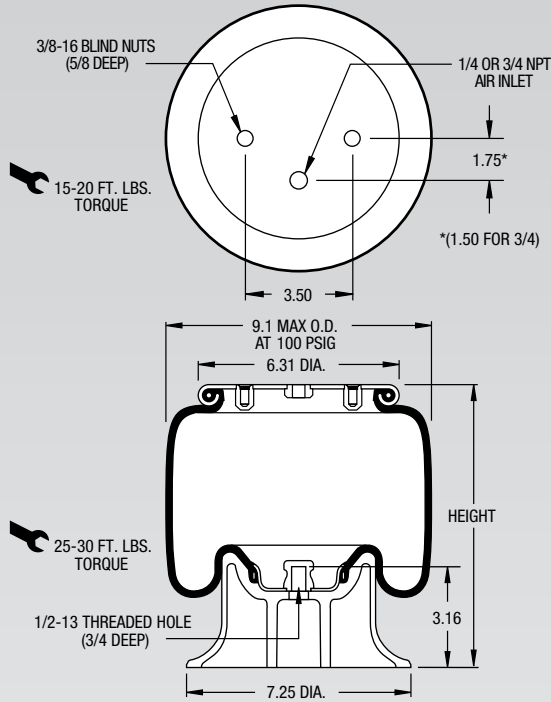

**NOTE:** Bellows will not compress properly with less than 10 PSIG internal pressure.

**NOTE:** A bead plate part is shown. This part is also available with a bead ring. Bolts are not included. See pages 8-10 for explanation.

Dynamic Characteristics at 10.0 in. Design Height (Required for Airmount isolator design only)				
Volume @ 100 PSIG = 313 in <sup>3</sup>			Natural Frequency	
Gage Pressure (PSIG)	Load (lbs.)	Spring Rate (lbs./in.)	CPM	HZ
40	1,180	280	92	1.53
60	1,810	356	83	1.39
80	2,450	453	81	1.35
100	3,120	552	79	1.32

CONSULT FIRESTONE BEFORE USING AS AIRMOUNT

RECOMMENDED AIRMOUNT DESIGN HEIGHT 10.0 INCHES

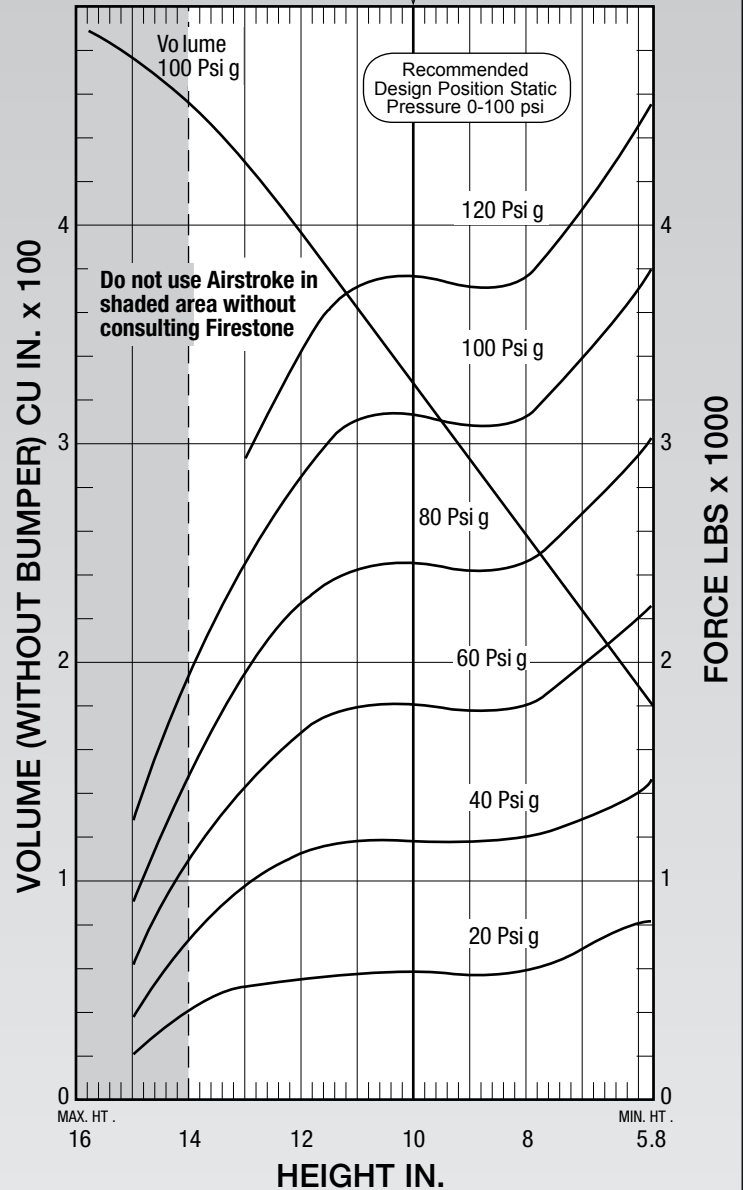

See page 12 for instructions on how to use chart.

Force Table (Use for Airstroke™ actuator design)						
Assembly Height (in.)	Volume @ 100 PSIG (in <sup>3</sup> )	Pounds Force				
		@20 PSIG	@40 PSIG	@60 PSIG	@80 PSIG	@100 PSIG
14.0	430	410	730	1,080	1,490	1,960
12.0	378	560	1,120	1,680	2,280	2,870
10.0	313	580	1,170	1,820	2,440	3,130
8.0	246	610	1,190	1,810	2,430	3,110
6.0	176	800	1,500	2,180	2,960	3,740

Description		Assembly Order No.
Style 1T14C-7	Blind nuts, 1/4 NPT	W01-358-5712
Two Ply Bellows	Blind nuts, 3/4 NPT	W01-358-5708
Assembly weight .....		7.0 lbs.
Style 1T28C-7	Blind nuts, 1/4 NPT	W01-358-5743
High Strength Bellows		

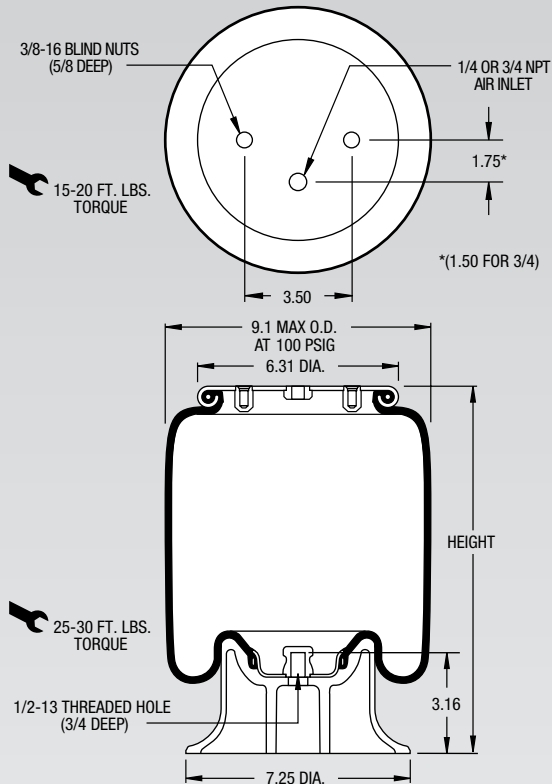

**NOTE: Bellows will not compress properly with less than 10 PSIG internal pressure.**

**NOTE: A bead plate part is shown. This part is also available with a bead ring. Bolts are not included. See pages 8-10 for explanation.**

Dynamic Characteristics at 13.0 in. Design Height (Required for Airmount isolator design only)				
Volume @ 100 PSIG = 490 in <sup>3</sup>			Natural Frequency	
Gage Pressure (PSIG)	Load (lbs.)	Spring Rate (lbs./in.)	CPM	HZ
40	1,250	166	68	1.14
60	1,920	243	67	1.12
80	2,610	305	64	1.07
100	3,260	397	66	1.10

CONSULT FIRESTONE BEFORE USING AS AIRMOUNT

RECOMMENDED AIRMOUNT DESIGN HEIGHT 13.0 INCHES

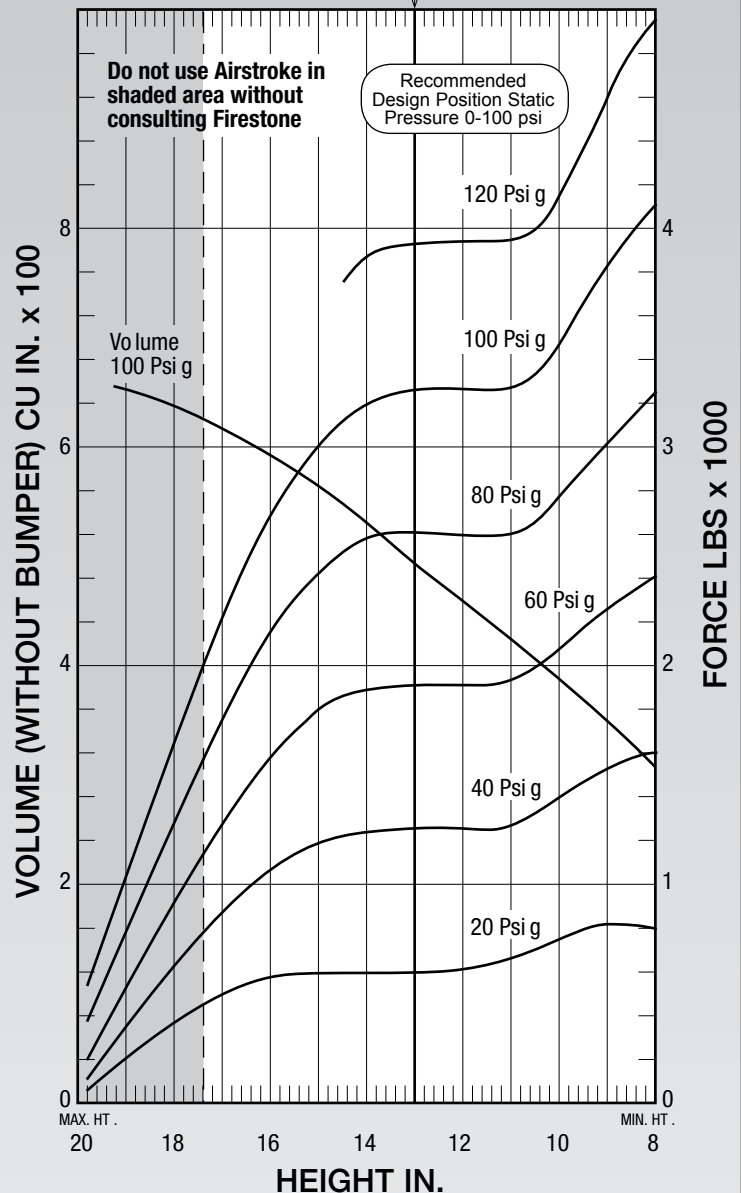

See page 12 for instructions on how to use chart.

Force Table (Use for Airstroke™ actuator design)						
Assembly Height (in.)	Volume @ 100 PSIG (in <sup>3</sup> )	Pounds Force				
		@20 PSIG	@40 PSIG	@60 PSIG	@80 PSIG	@100 PSIG
17.0	615	500	890	1,310	1,790	2,260
15.0	558	600	1,210	1,820	2,460	3,070
13.0	490	600	1,250	1,920	2,610	3,260
11.0	421	660	1,280	1,930	2,610	3,270
9.0	349	820	1,540	2,270	3,040	3,850

# 1T15T-1

# Firestone

# AIRSTROKE™

ACTUATORS

# AIRMOUNT™

ISOLATORS

Description		Assembly Order No.
Style	Blind nuts, 1/4 NPT	W01-358-9400
1T15T-1	Blind nuts, 1/4 NPT, bumper	W01-358-9402
Two Ply Bellows	Blind nuts, 3/4 NPT	W01-358-9401
Assembly weight .....		9.6 lbs.

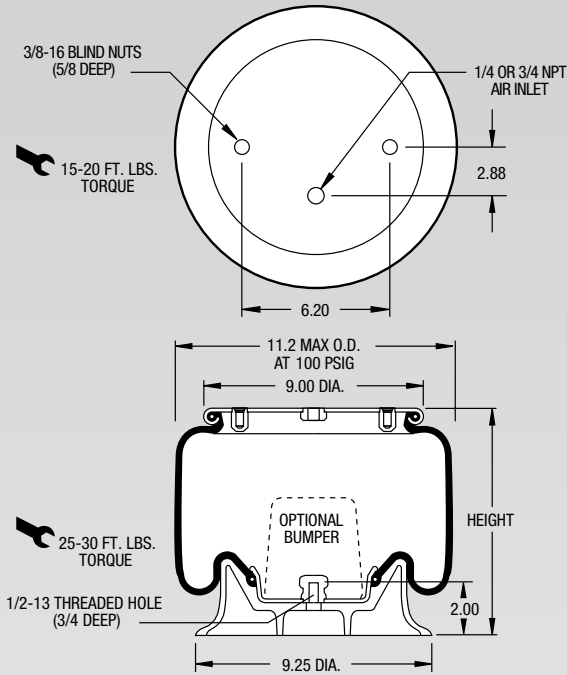

**NOTE:** Bellows will not compress properly with less than 10 PSIG internal pressure.

**NOTE:** A bead plate part is shown. This part is also available with a bead ring. Bolts are not included. See pages 8-10 for explanation..

CONSULT FIRESTONE BEFORE USING AS AIRMOUNT

RECOMMENDED AIRMOUNT DESIGN HEIGHT 7.0 INCHES

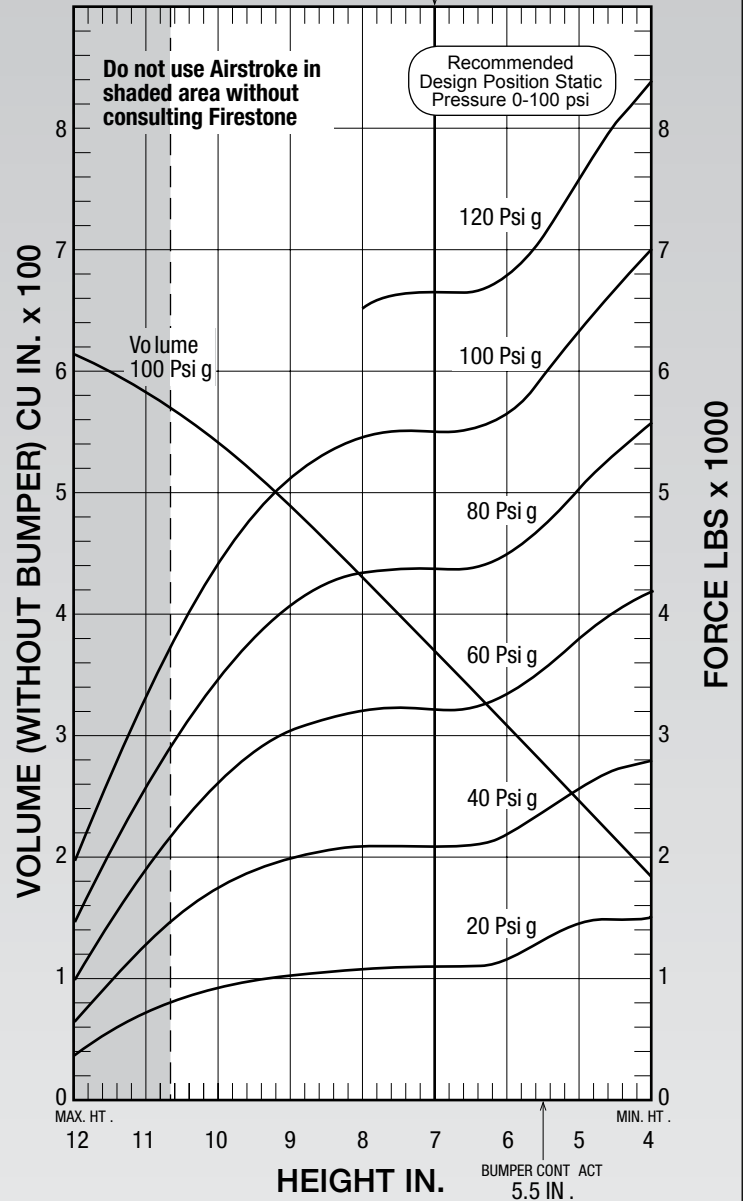

See page 12 for instructions on how to use chart.

Dynamic Characteristics at 7.0 in. Design Height (Required for Airmount isolator design only)				
Volume @ 100 PSIG = 373 in <sup>3</sup>			Natural Frequency	
Gage Pressure (PSIG)	Load (lbs.)	Spring Rate (lbs./in.)	CPM	HZ
40	2,100	658	105	1.75
60	3,220	908	100	1.66
80	4,370	1,168	97	1.62
100	5,490	1,408	95	1.58

Force Table (Use for Airstroke™ actuator design)						
Assembly Height (in.)	Volume @ 100 PSIG (in <sup>3</sup> )	Pounds Force				
		@20 PSIG	@40 PSIG	@60 PSIG	@80 PSIG	@100 PSIG
10.0	541	920	1,750	2,600	3,470	4,410
9.0	490	1,030	2,010	3,050	4,050	5,130
8.0	433	1,100	2,090	3,210	4,330	5,470
7.0	373	1,110	2,100	3,220	4,370	5,490
6.0	314	1,160	2,190	3,330	4,480	5,650
5.0	251	1,450	2,570	3,780	5,010	6,290

**NOTE: Replacement for Style 1T15S-6**

Description		Assembly Order No.
Style 1T15LP-3	Blind nuts, 1/4 NPT, bumper	W01-358-9049
Two Ply Bellows	Blind nuts, 3/4 NPT	W01-358-9051
Assembly weight .....		13.7 lbs.

CONSULT FIRESTONE BEFORE USING AS AIRMOUNT

RECOMMENDED AIRMOUNT DESIGN HEIGHT 12.0 INCHES

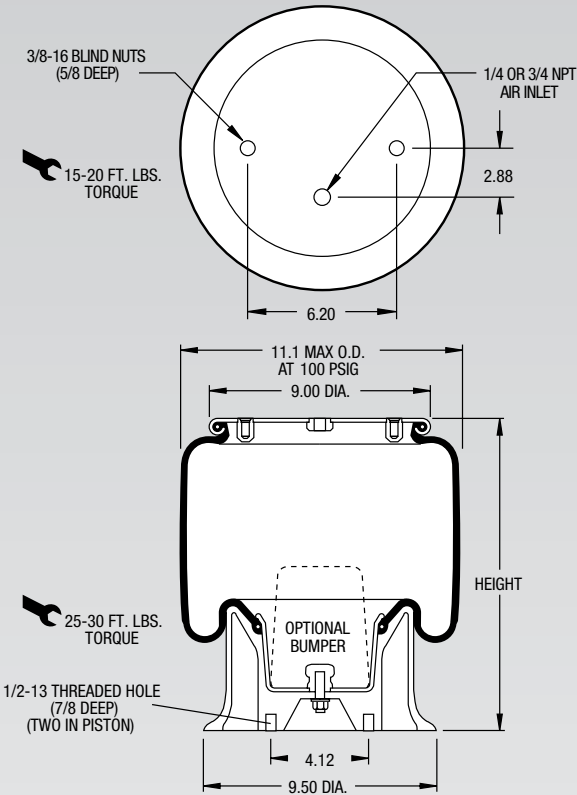

**NOTE: Bellows will not compress properly with less than 20 PSIG internal pressure.**

**NOTE: A bead plate part is shown. This part is also available with a bead ring. Bolts are not included. See pages 8-10 for explanation.**

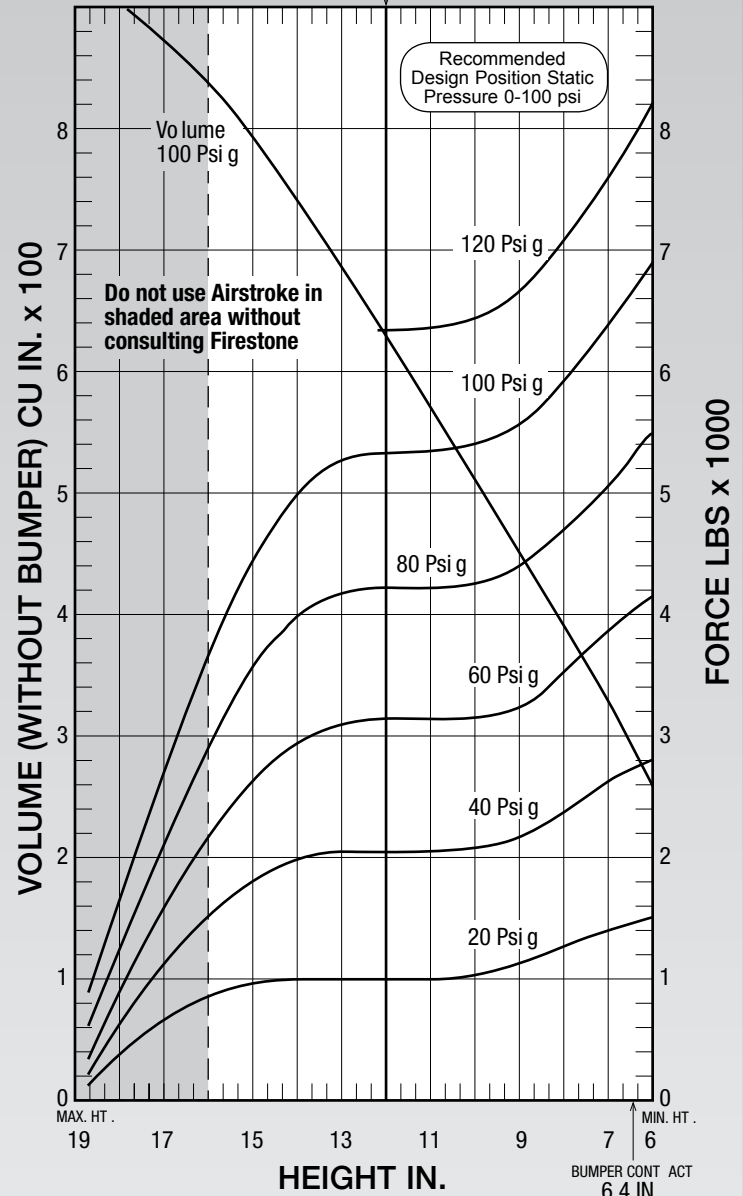

See page 12 for instructions on how to use chart.

Dynamic Characteristics at 12.0 in. Design Height (Required for Airmount isolator design only)				
Volume @ 100 PSIG = 625 in <sup>3</sup>			Natural Frequency	
Gage Pressure (PSIG)	Load (lbs.)	Spring Rate (lbs./in.)	CPM	HZ
40	2,040	363	79	1.32
60	3,140	513	76	1.26
80	4,220	657	74	1.23
100	5,340	813	73	1.22

Force Table (Use for Airstroke™ actuator design)						
Assembly Height (in.)	Volume @ 100 PSIG (in <sup>3</sup> )	Pounds Force				
		@20 PSIG	@40 PSIG	@60 PSIG	@80 PSIG	@100 PSIG
16.0	834	830	1,580	2,140	2,860	3,600
14.0	739	1,010	1,980	2,930	3,980	5,000
12.0	625	980	2,040	3,140	4,220	5,340
10.0	509	1,030	2,100	3,160	4,270	5,410
8.0	392	1,280	2,380	3,520	4,690	5,930

# 1T15L-4

# Firestone

# AIRSTROKE™

ACTUATORS

# AIRMOUNT™

ISOLATORS

Description		Assembly Order No.
Style 1T15L-4	Blind nuts, 1/4 NPT	W01-358-9414
Two Ply Bellows		
Assembly weight .....		13.5 lbs.

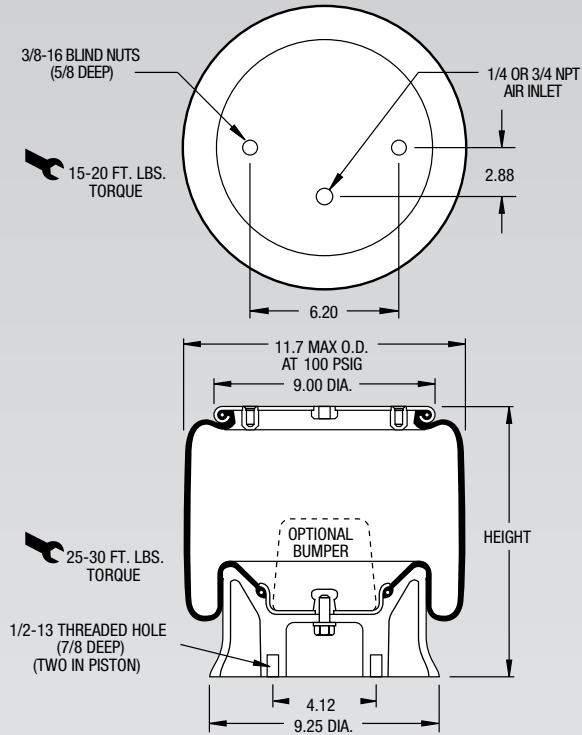

**NOTE:** Bellows will not compress properly with less than 10 PSIG internal pressure.

**NOTE:** A bead plate part is shown. This part is also available with a bead ring. Bolts are not included. See pages 8-10 for explanation.

CONSULT FIRESTONE BEFORE USING AS AIRMOUNT

RECOMMENDED AIRMOUNT DESIGN HEIGHT 11.0 INCHES

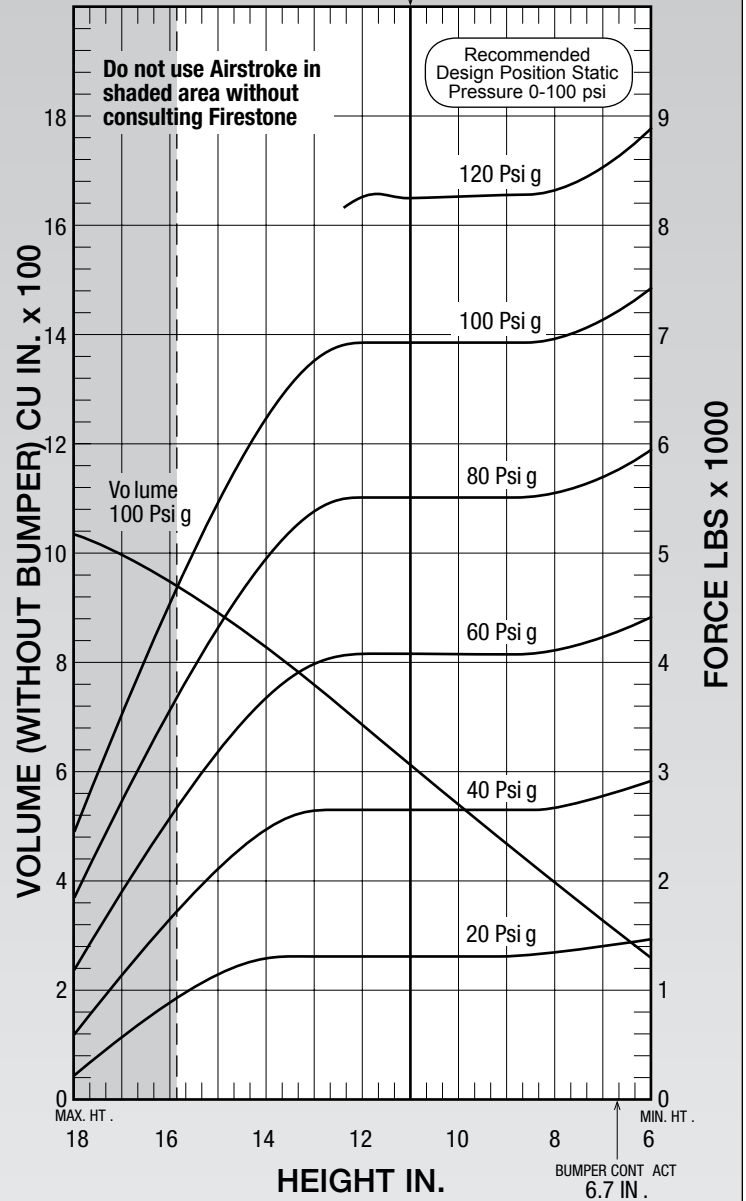

See page 12 for instructions on how to use chart.

Dynamic Characteristics at 11.0 in. Design Height (Required for Airmount isolator design only)				
Volume @ 100 PSIG = 625 in <sup>3</sup>			Natural Frequency	
Gage Pressure (PSIG)	Load (lbs.)	Spring Rate (lbs./in.)	CPM	HZ
40	2,650	583	88	1.47
60	4,080	823	84	1.40
80	5,510	1,055	82	1.37
100	6,930	1,281	81	1.34

Force Table (Use for Airstroke™ actuator design)						
Assembly Height (in.)	Volume @ 100 PSIG (in <sup>3</sup> )	Pounds Force				
		@20 PSIG	@40 PSIG	@60 PSIG	@80 PSIG	@100 PSIG
15.0	898	1,120	2,110	3,150	4,300	5,440
13.0	768	1,310	2,630	3,970	5,360	6,720
11.0	625	1,310	2,650	4,080	5,510	6,930
9.0	479	1,310	2,650	4,080	5,500	6,920
7.0	333	1,390	2,780	4,210	5,690	7,120

Description		Assembly Order No.
Style 1T15M-0  Two Ply Bellows	Blind nuts, 1/4 NPT	W01-358-9030
	Blind nuts, 1/4 NPT, rubber bumper	W01-358-9031
	Blind nuts, 3/4 NPT	W01-358-9034
	Blind nuts, 3/4 NPT, rubber bumper	W01-358-9036
	Countersunk steel bead ring, 1 3/8 bolts, nuts, washers	W01-358-9038
	Integral studs, 1/4 NPT	W01-358-9035
Assembly weight .....		11.5 lbs.

Recommended Design Position Static Pressure 0-100 psi

CONSULT FIRESTONE BEFORE USING AS AIRMOUNT

RECOMMENDED AIRMOUNT DESIGN HEIGHT 7.5 INCHES

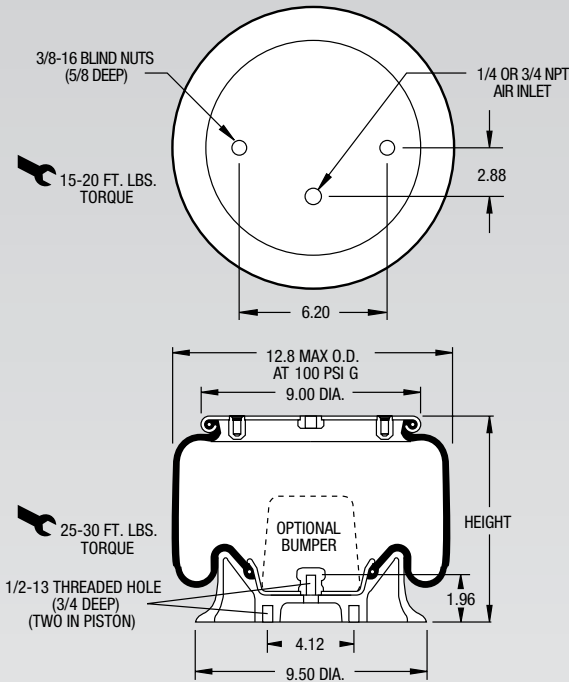

**NOTE:** Bellows will not compress properly with less than 10 PSIG internal pressure.

**NOTE:** A bead plate part is shown. This part is also available with a bead ring. Bolts are not included. See pages 8-10 for explanation.

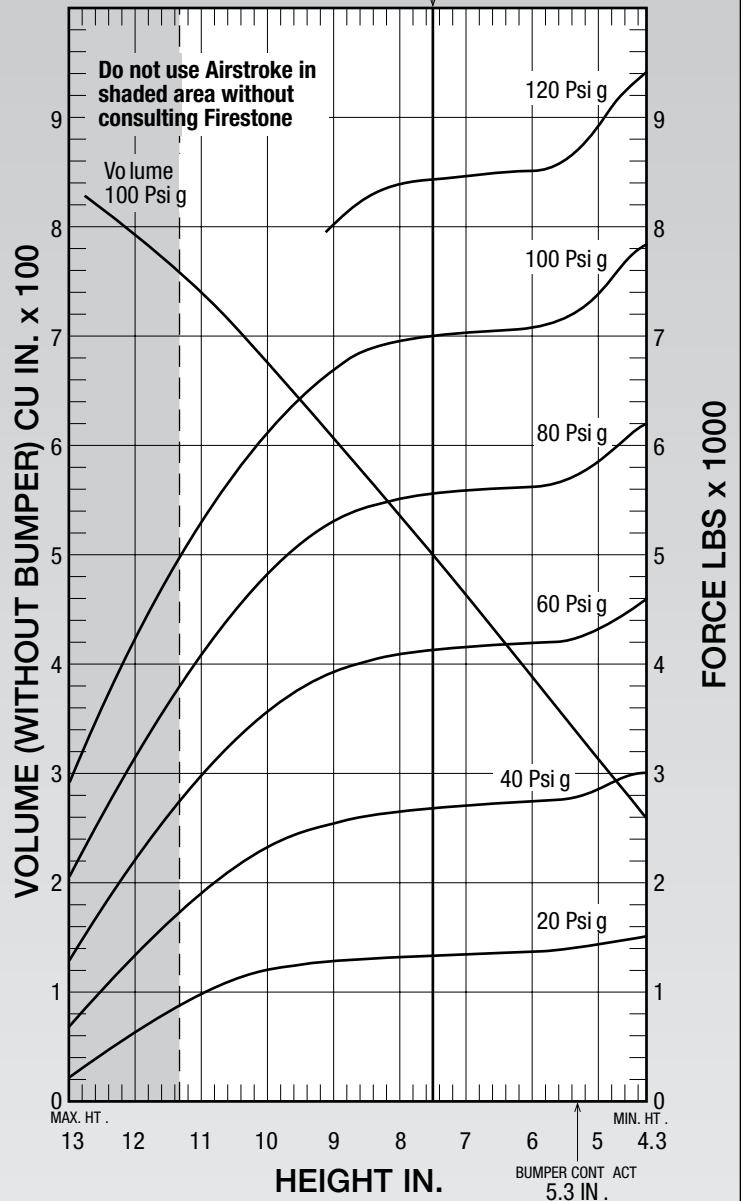

See page 12 for instructions on how to use chart.

Dynamic Characteristics at 7.5 in. Design Height (Required for Airmount isolator design only)				
Volume @ 100 PSIG = 498 in <sup>3</sup>			Natural Frequency	
Gage Pressure (PSIG)	Load (lbs.)	Spring Rate (lbs./in.)	CPM	HZ
40	2,670	793	102	1.71
60	4,120	1,105	97	1.62
80	5,540	1,399	94	1.57
100	6,990	1,690	92	1.54

Force Table (Use for Airstroke™ actuator design)						
Assembly Height (in.)	Volume @ 100 PSIG (in <sup>3</sup> )	Pounds Force				
		@20 PSIG	@40 PSIG	@60 PSIG	@80 PSIG	@100 PSIG
11.0	737	980	1,920	2,980	4,120	5,300
10.0	675	1,180	2,310	3,550	4,810	6,130
9.0	606	1,270	2,540	3,910	5,290	6,710
8.0	534	1,300	2,630	4,080	5,500	6,950
7.0	462	1,320	2,690	4,140	5,570	7,010
6.0	389	1,350	2,730	4,170	5,610	7,070
5.0	314	1,410	2,840	4,310	5,840	7,370

# 1T15M-2

# Firestone

# AIRSTROKE™

ACTUATORS

# AIRMOUNT™

ISOLATORS

Description		Assembly Order No.
Style	Blind nuts, 1/4 NPT	W01-358-9042
1T15M-2	Blind nuts, 1/4 NPT, bumper	W01-358-9053
Two	Blind nuts, 3/4 NPT	W01-358-9054
Ply	Blind nuts, 3/4 NPT, bumper	W01-358-9099
Bel lows		
Assembly weight .....		12.5 lbs.

Recommended Design Position Static Pressure 0-100 psi

CONSULT FIRESTONE BEFORE USING AS AIRMOUNT

RECOMMENDED AIRMOUNT DESIGN HEIGHT 9.5 INCHES

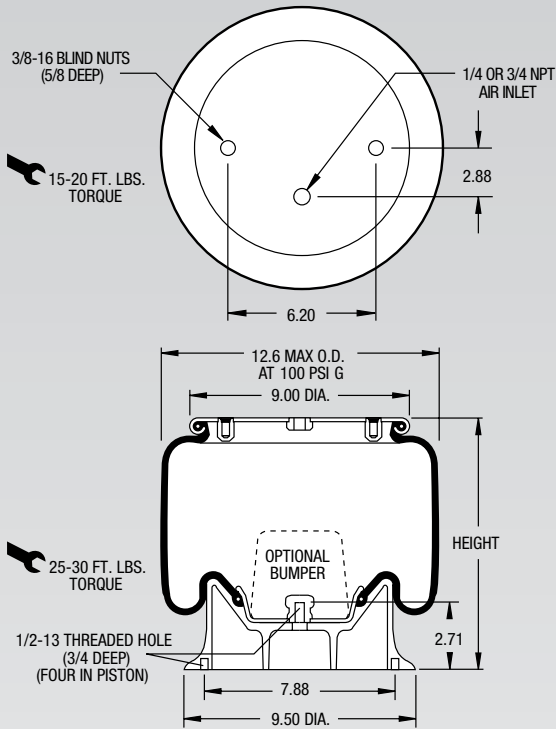

**NOTE:** Bellows will not compress properly with less than 10 PSIG internal pressure.

**NOTE:** A bead plate part is shown. This part is also available with a bead ring. Bolts are not included. See pages 8-10 for explanation.

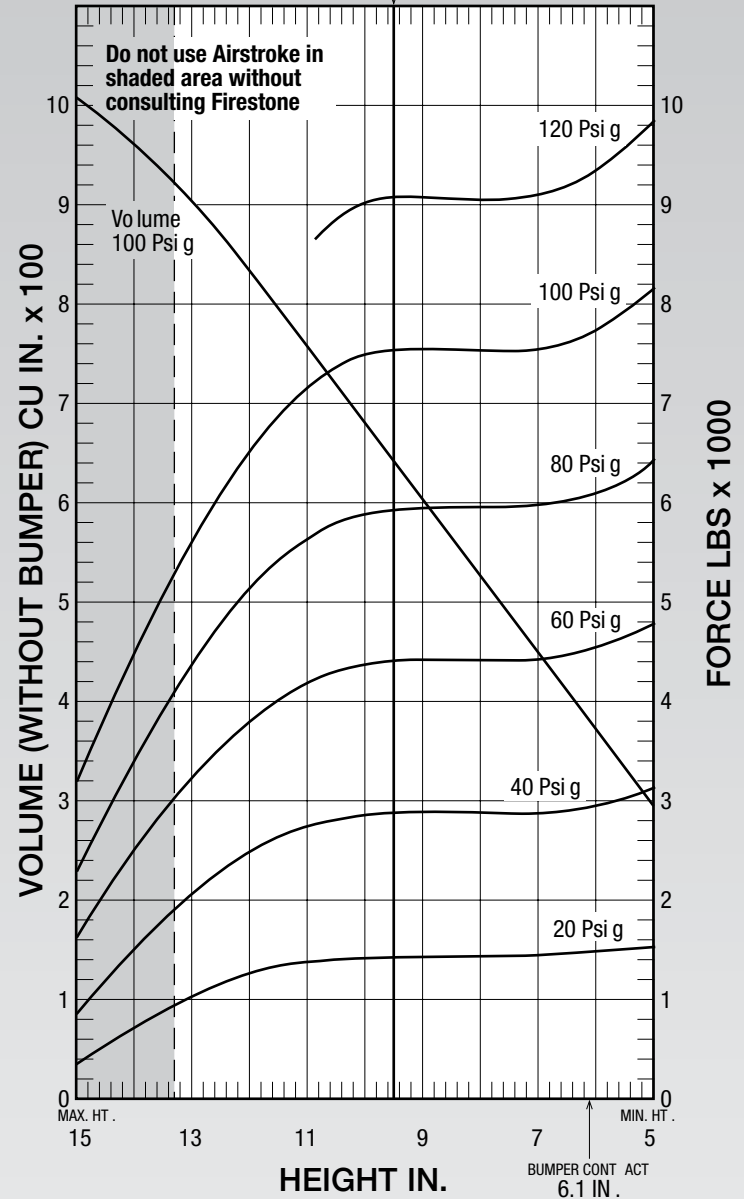

Volume @ 100 PSIG = 648 in <sup>3</sup>			Natural Frequency	
Gage Pressure (PSIG)	Load (lbs.)	Spring Rate (lbs./in.)	CPM	HZ
40	2,850	693	93	1.54
60	4,370	965	88	1.47
80	5,900	1,238	86	1.43
100	7,510	1,510	84	1.40

See page 12 for instructions on how to use chart.

Assembly Height (in.)	Volume @ 100 PSIG (in <sup>3</sup> )	Pounds Force				
		@20 PSIG	@40 PSIG	@60 PSIG	@80 PSIG	@100 PSIG
13.0	900	1,000	2,030	3,170	4,320	5,580
12.0	835	1,210	2,420	3,720	5,040	6,440
11.0	763	1,330	2,680	4,120	5,570	7,100
10.0	687	1,380	2,820	4,330	5,850	7,460
9.0	609	1,400	2,860	4,390	5,920	7,530
8.0	531	1,400	2,850	4,390	5,930	7,510
7.0	453	1,410	2,860	4,410	5,950	7,530
6.0	374	1,440	2,930	4,530	6,080	7,730



Description		Assembly Order No.
Style 1T15M-4	Blind nuts, 1/4 NPT	W01-358-9056
	Blind nuts, 1/4 NPT, bumper	W01-358-9057
Two Ply Bellows	Blind nuts, 3/4 NPT	W01-358-9062
	Blind nuts, 3/4 NPT, bumper	W01-358-9060
Assembly weight .....		13.7 lbs

Recommended Design Position Static Pressure 0-100 psi

CONSULT FIRESTONE BEFORE USING AS AIRMOUNT

RECOMMENDED AIRMOUNT DESIGN HEIGHT 12.0 INCHES

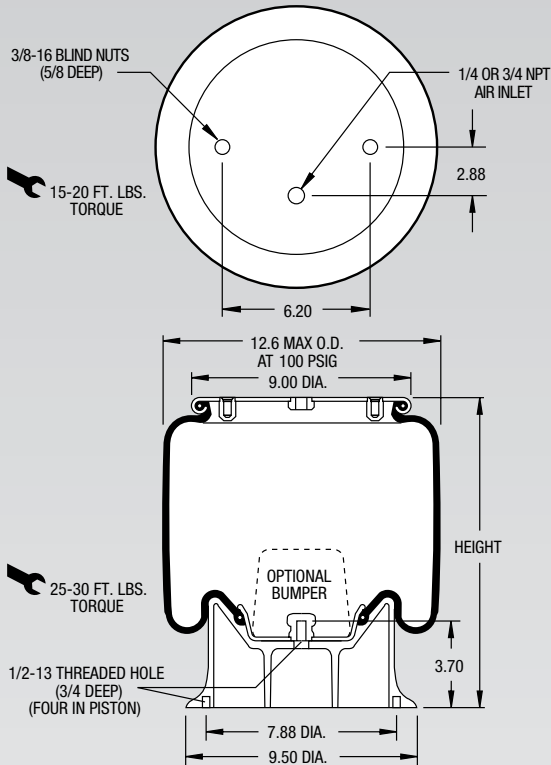

**NOTE:** Bellows will not compress properly with less than 10 PSIG internal pressure.

**NOTE:** A bead plate part is shown. This part is also available with a bead ring. Bolts are not included. See pages 8-10 for explanation.

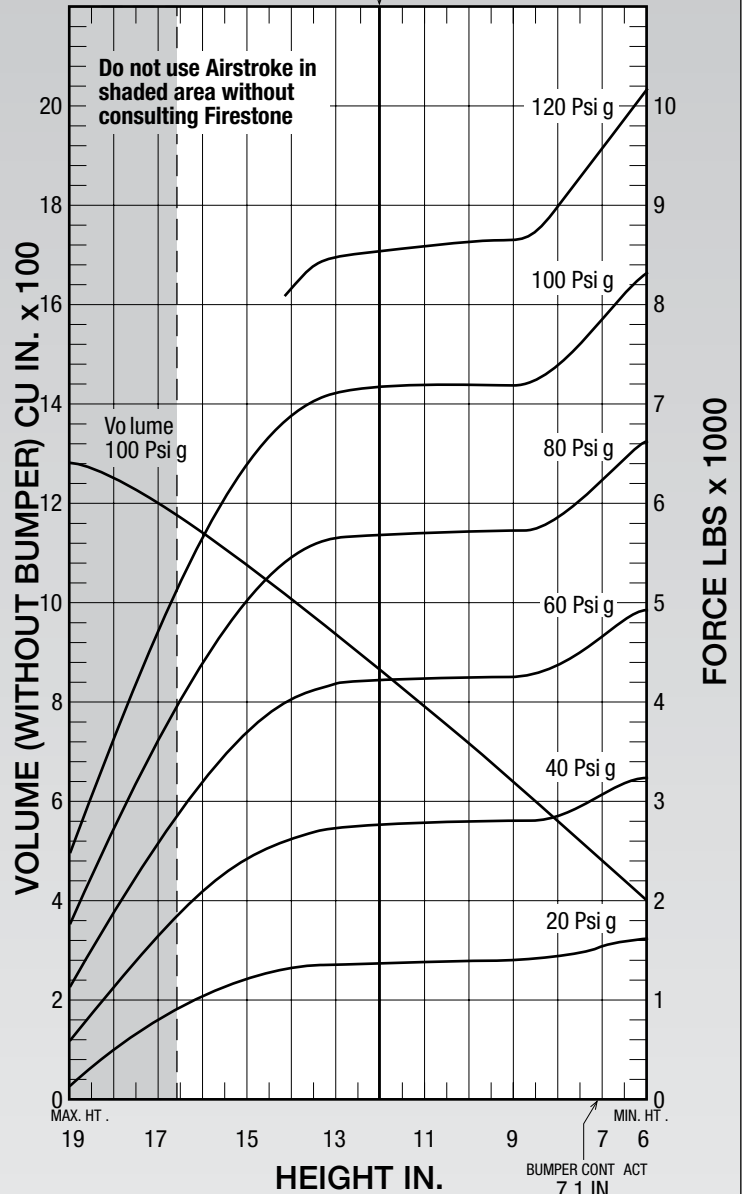

See page 12 for instructions on how to use chart.

Dynamic Characteristics at 12.0 in. Design Height (Required for Airmount isolator design only)				
Volume @ 100 PSIG = 861 in <sup>3</sup>			Natural Frequency	
Gage Pressure (PSIG)	Load (lbs.)	Spring Rate (lbs./in.)	CPM	HZ
40	2,770	459	77	1.28
60	4,210	620	72	1.20
80	5,690	803	71	1.18
100	7,190	986	70	1.16

Force Table (Use for Airstroke™ actuator design)						
Assembly Height (in.)	Volume @ 100 PSIG (in <sup>3</sup> )	Pounds Force				
		@20 PSIG	@40 PSIG	@60 PSIG	@80 PSIG	@100 PSIG
16.0	1,146	1,060	2,110	3,240	4,410	5,680
14.0	1,010	1,330	2,650	4,050	5,460	6,910
12.0	861	1,380	2,770	4,210	5,690	7,190
10.0	711	1,390	2,790	4,230	5,720	7,190
8.0	561	1,440	2,880	4,370	5,860	7,400

# 1T15M-6 Firestone

**AIRSTROKE**  
ACTUATORS

**AIRMOUNT**  
ISOLATORS

Description		Assembly Order No.
Style	Blind nuts, 1/4 NPT	W01-358-9079
1T15M-6	Blind nuts, 1/4 NPT, bumper	W01-358-9096
Two Ply Bellows	Blind nuts, 3/4 NPT	W01-358-9089
	Blind nuts, 3/4 NPT, bumper	W01-358-9088
	Blind nuts, 3/4 NPT (piston not included)	W01-358-0730
Assembly weight (bead plate version, no bumper)		13.0 lbs.

Recommended Design Position Static Pressure 0-100 psi

CONSULT FIRESTONE BEFORE USING AS AIRMOUNT

RECOMMENDED AIRMOUNT DESIGN HEIGHT 14.0 INCHES

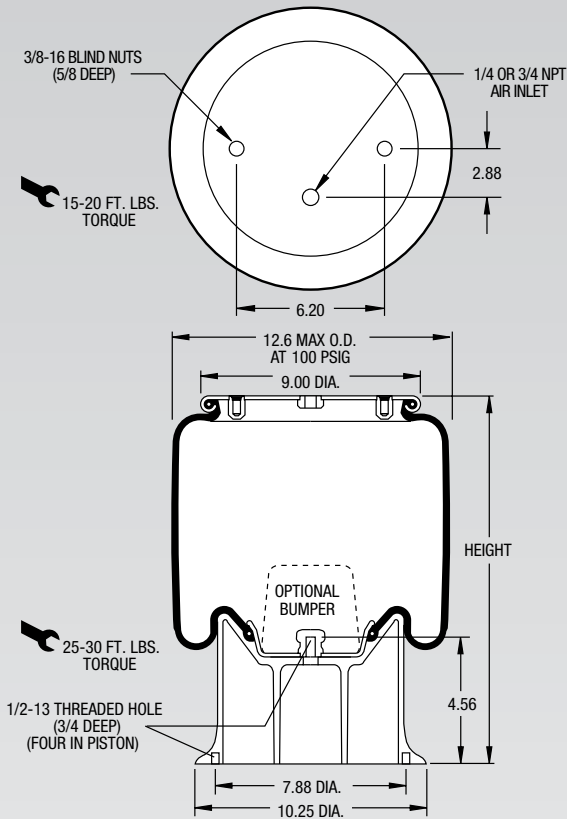

**NOTE:** Bellows will not compress properly with less than 10 PSIG internal pressure.

**NOTE:** A bead plate part is shown. This part is also available with a bead ring. Bolts are not included. See pages 8-10 for explanation.

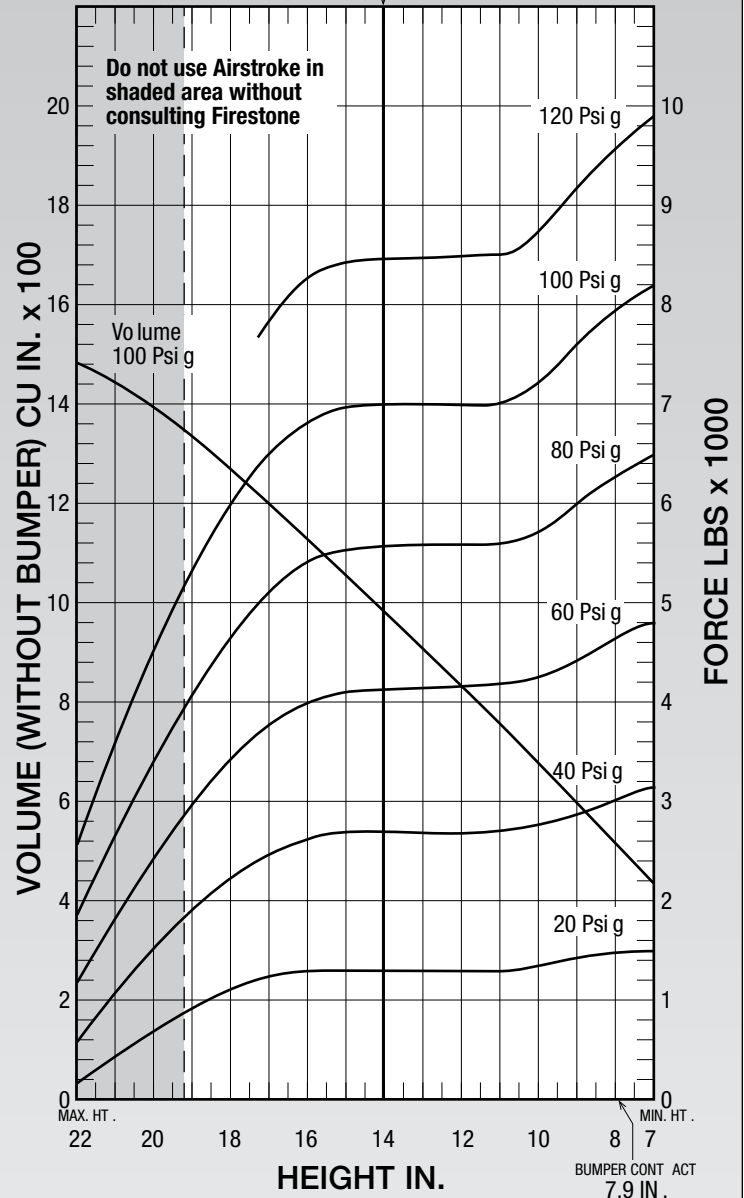

See page 12 for instructions on how to use chart.

Dynamic Characteristics at 14.0 in. Design Height (Required for Airmount isolator design only)				
Volume @ 100 PSIG = 987 in <sup>3</sup>			Natural Frequency	
Gage Pressure (PSIG)	Load (lbs.)	Spring Rate (lbs./in.)	CPM	HZ
40	2,730	395	71	1.19
60	4,130	541	68	1.13
80	5,590	707	67	1.12
100	7,030	852	65	1.09

Force Table (Use for Airstroke™ actuator design)						
Assembly Height (in.)	Volume @ 100 PSIG (in <sup>3</sup> )	Pounds Force				
		@20 PSIG	@40 PSIG	@60 PSIG	@80 PSIG	@100 PSIG
18.0	1,274	1,100	2,220	3,420	4,670	5,980
16.0	1,134	1,290	2,640	4,000	5,410	6,840
14.0	987	1,330	2,730	4,130	5,590	7,030
12.0	841	1,330	2,710	4,170	5,590	7,010
10.0	693	1,380	2,790	4,270	5,730	7,240
8.0	533	1,500	3,060	4,670	6,280	7,950

Description		Assembly Order No.
Style	Blind nuts, 1/4 NPT	W01-358-9108
1T15M-9	Blind nuts, 1/4 NPT, bumper	W01-358-9104
Two Ply Bellows	Blind nuts, 3/4 NPT	W01-358-9106
	Blind nuts, 3/4 NPT, bumper	W01-358-9117
Assembly weight .....		14.9 lbs.

Recommended Design Position Static Pressure 0-100 psi

CONSULT FIRESTONE BEFORE USING AS AIRMOUNT

RECOMMENDED AIRMOUNT DESIGN HEIGHT 17.0 INCHES

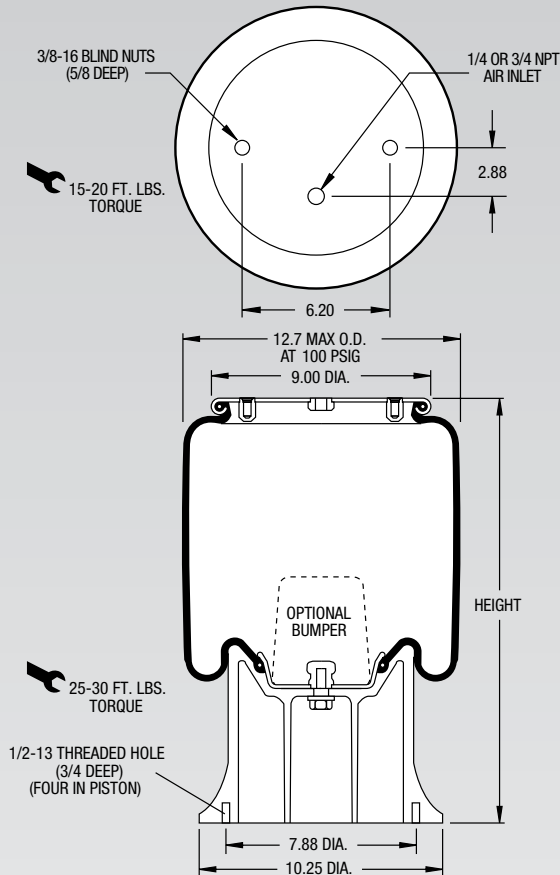

**NOTE:** Bellows will not compress properly with less than 10 PSIG internal pressure.

**NOTE:** A bead plate part is shown. This part is also available with a bead ring. Bolts are not included. See pages 8-10 for explanation.

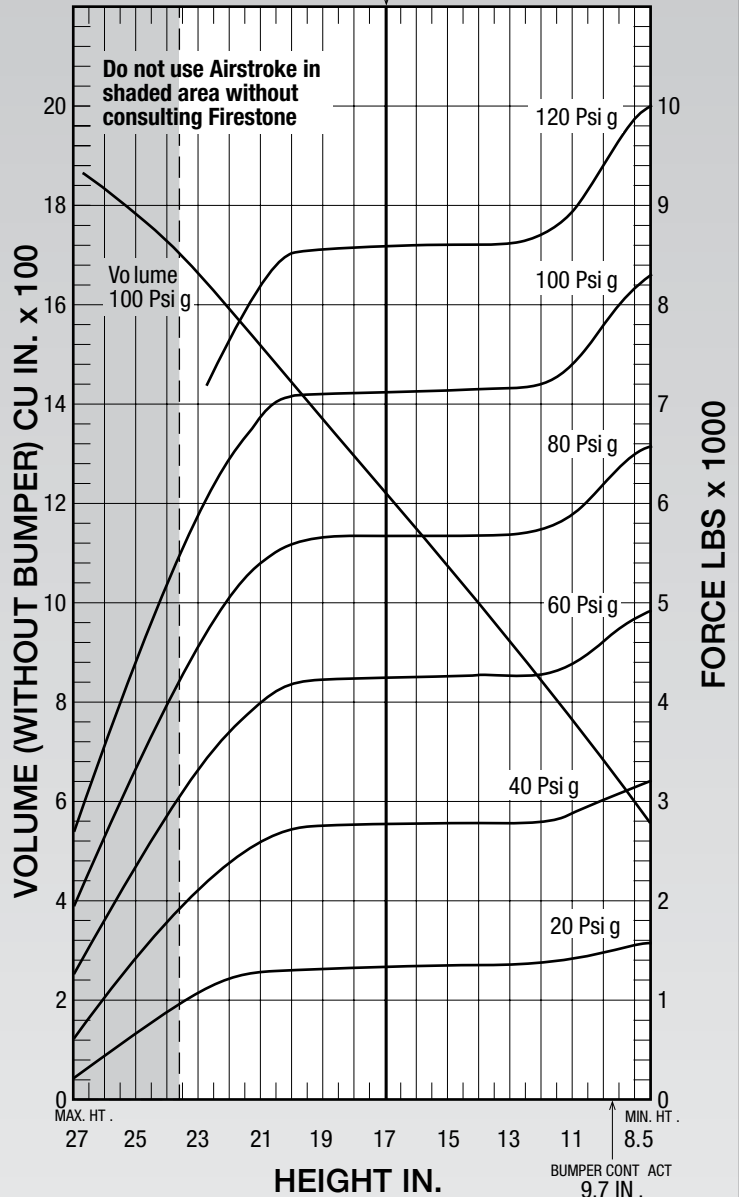

See page 12 for instructions on how to use chart.

Dynamic Characteristics at 17.0 in. Design Height (Required for Airmount isolator design only)				
Volume @ 100 PSIG = 1,217 in <sup>3</sup>			Natural Frequency	
Gage Pressure (PSIG)	Load (lbs.)	Spring Rate (lbs./in.)	CPM	HZ
40	2,770	287	60	1.01
60	4,250	425	59	.99
80	5,680	546	58	.97
100	7,140	659	57	.95

Force Table (Use for Airstroke™ actuator design)						
Assembly Height (in.)	Volume @ 100 PSIG (in <sup>3</sup> )	Pounds Force				
		@20 PSIG	@40 PSIG	@60 PSIG	@80 PSIG	@100 PSIG
23.0	1,658	1,090	2,150	3,340	4,560	5,850
21.0	1,517	1,290	2,600	4,020	5,380	6,860
19.0	1,368	1,340	2,780	4,240	5,660	7,110
17.0	1,217	1,370	2,770	4,250	5,680	7,140
15.0	1,067	1,380	2,810	4,290	5,690	7,150
13.0	916	1,390	2,810	4,280	5,700	7,170
11.0	760	1,460	2,950	4,430	5,940	7,500
9.0	596	1,580	3,200	4,880	6,550	8,230

Description		Assembly Order No.
Style 1T19L-7	Blind nuts, 1/4 NPT	W01-358-9148
	Blind nuts, 1/4 NPT, bumper	W01-358-9149
Two Ply Bellows	Blind nuts, 3/4 NPT	W01-358-9172
	Blind nuts, 3/4 NPT, bumper	W01-358-9160
	Countersunk steel bead ring 1 3/4 bolts, nuts, washers	W01-358-9165
Assembly weight .....		20.9 lbs.

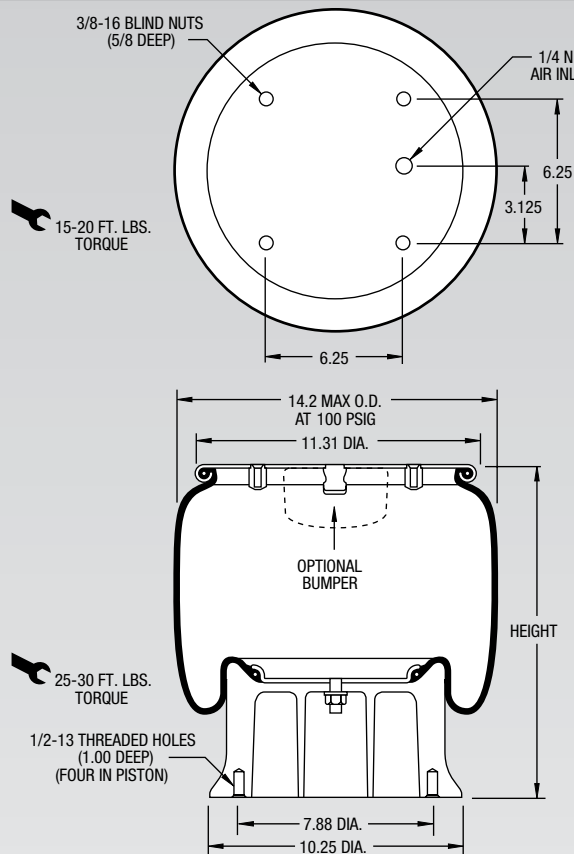

**NOTE:** Bellows will not compress properly with less than 20 PSIG internal pressure.

**NOTE:** A bead plate part is shown. This part is also available with a bead ring. Bolts are not included. See pages 8-10 for explanation.

Recommended Design Position Static Pressure 0-100 psi

CONSULT FIRESTONE BEFORE USING AS AIRMOUNT

RECOMMENDED AIRMOUNT DESIGN HEIGHT 13.0 INCHES

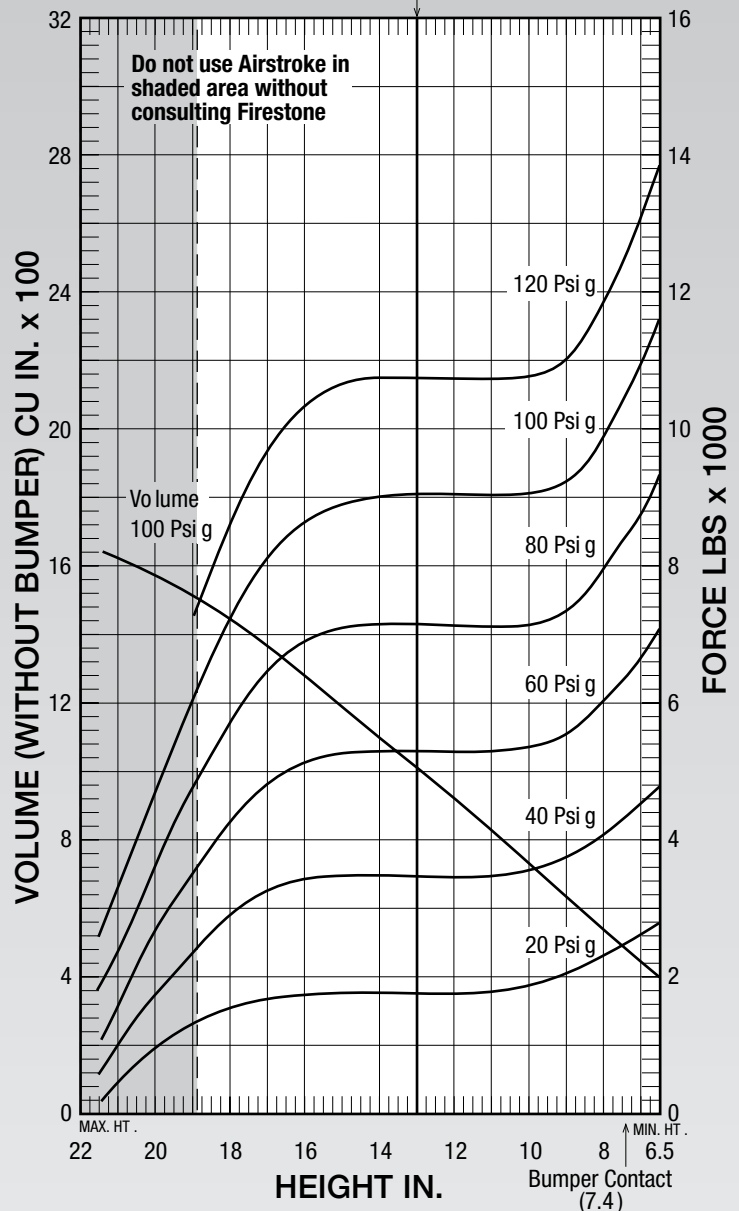

See page 12 for instructions on how to use chart.

Dynamic Characteristics at 13.0 in. Design Height (Required for Airmount isolator design only)				
Volume @ 100 PSIG = 921 in <sup>3</sup>			Natural Frequency	
Gage Pressure (PSIG)	Load (lbs.)	Spring Rate (lbs./in.)	CPM	HZ
40	3,482	532	73	1.22
60	5,297	777	72	1.20
80	7,101	982	70	1.17
100	8,984	1,227	69	1.15

Force Table (Use for Airstroke™ actuator design)						
Assembly Height (in.)	Volume @ 100 PSIG (in <sup>3</sup> )	Pounds Force				
		@20 PSIG	@40 PSIG	@60 PSIG	@80 PSIG	@100 PSIG
18.50	1,480	1,398	2,605	3,859	5,194	6,645
16.50	1,328	1,705	3,309	4,952	6,624	8,350
14.50	1,155	1,760	3,482	5,293	7,095	8,964
12.50	969	1,760	3,482	5,297	7,101	8,984
10.50	778	1,760	3,482	5,297	7,101	8,984
8.50	591	2,126	3,876	5,748	7,597	9,515

Description		Assembly Order No.
Style 1T19L-11	Blind nuts, 1/4 NPT	W01-358-9155
	Blind nuts, 1/4 NPT, bumper	W01-358-9156
Two Ply Bellows	Blind nuts, 3/4 NPT	W01-358-9153
	Blind nuts, 3/4 NPT, bumper	W01-358-2132
	Countersunk steel bead ring 1 3/4 bolts, nuts, washers	W01-358-9162
Assembly weight .....		20.4 lbs.

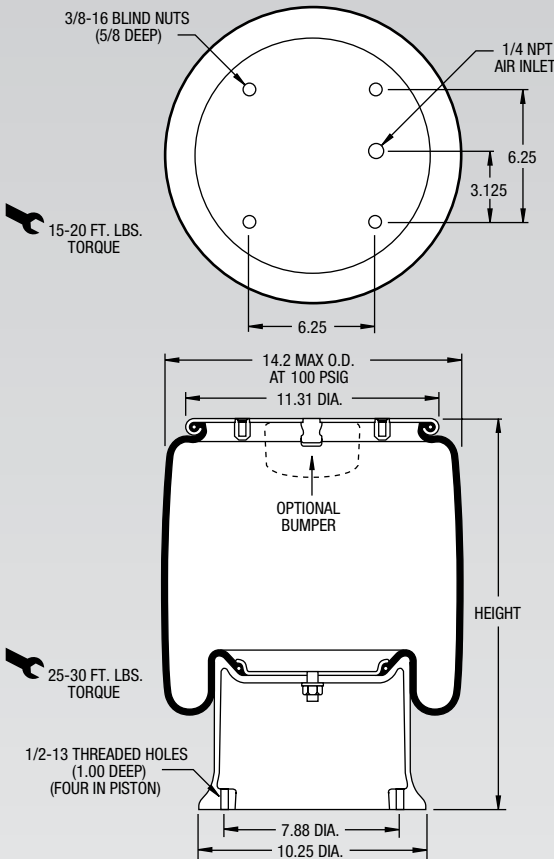

**NOTE:** Bellows will not compress properly with less than 20 PSIG internal pressure.

**NOTE:** A bead plate part is shown. This part is also available with a bead ring. Bolts are not included. See pages 8-10 for explanation.

Dynamic Characteristics at 17.0 in. Design Height (Required for Airmount isolator design only)				
Volume @ 100 PSIG = 1,337 in <sup>3</sup>			Natural Frequency	
Gage Pressure (PSIG)	Load (lbs.)	Spring Rate (lbs./in.)	CPM	HZ
40	3,411	428	67	1.12
60	5,151	602	64	1.07
80	6,911	765	63	1.05
100	8,711	927	61	1.02

CONSULT FIRESTONE BEFORE USING AS AIRMOUNT

RECOMMENDED AIRMOUNT DESIGN HEIGHT 17.0 INCHES

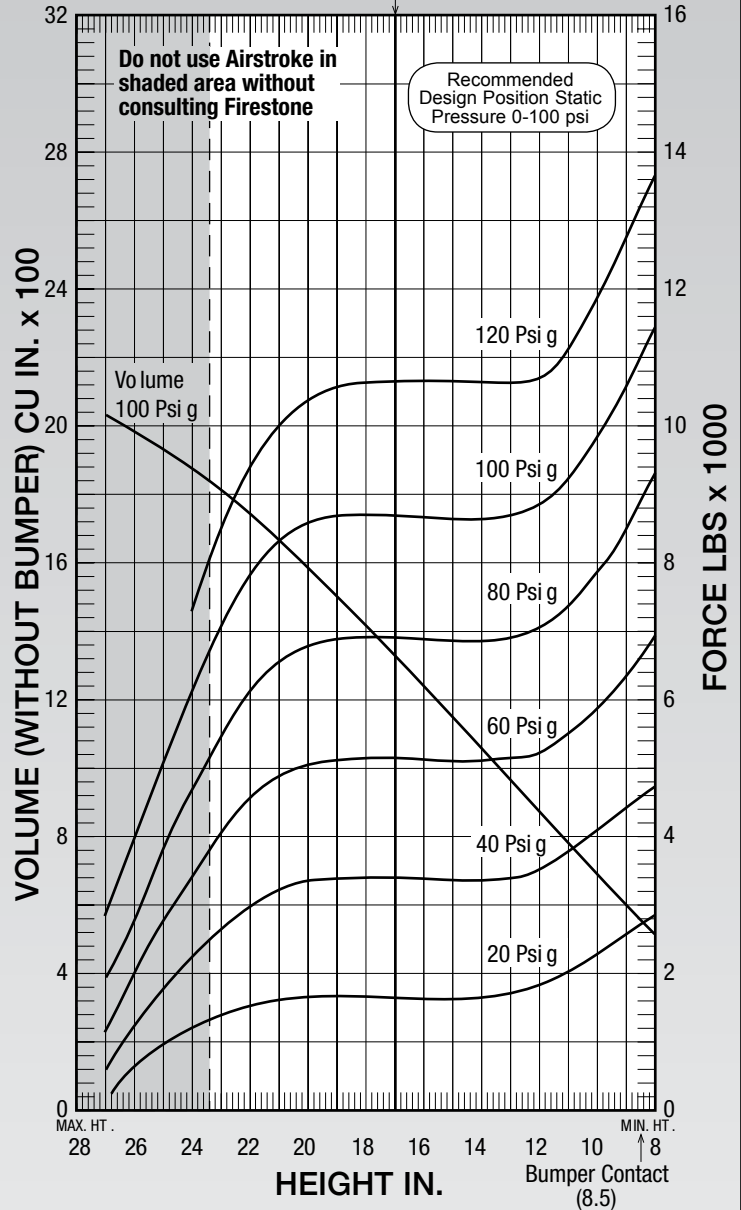

See page 12 for instructions on how to use chart.

Force Table (Use for Airstroke™ actuator design)						
Assembly Height (in.)	Volume @ 100 PSIG (in <sup>3</sup> )	Pounds Force				
		@20 PSIG	@40 PSIG	@60 PSIG	@80 PSIG	@100 PSIG
20.0	1,597	1,650	3,341	5,068	6,843	8,619
18.0	1,427	1,650	3,411	5,151	6,911	8,711
16.0	1,247	1,650	3,411	5,151	6,911	8,711
14.0	1,060	1,650	3,411	5,151	6,911	8,711
12.0	872	1,830	3,510	5,278	7,101	8,903
10.0	688	2,283	4,100	5,960	7,946	9,911











# INDEX

## ORDER NUMBER TO STYLE NUMBER TO PAGE NUMBER

ORDER NUMBER	STYLE NUMBER	SEE PAGE
WA1-358-5676	STYLE 50-P-10	35
WA1-358-5674	STYLE 70-P-13	36
WA1-358-5677	STYLE 120-P-25	37
W01-A72-7518	STYLE 116	46
W01-139-0201	STYLE 201	70
W01-139-0207	STYLE 207	72
W01-358-0010	STYLE 16	42
W01-358-0017	STYLE 16	42
W01-358-0030	STYLE 268 (formerly 25)	59
W01-358-0048	STYLE 267-1.5 (formerly 255-1.5)	60
W01-358-0100	STYLE 110	45
W01-358-0112	STYLE 110	45
W01-358-0118	STYLE 115	48
W01-358-0119	STYLE 119	54
W01-358-0127	STYLE 131	43
W01-358-0131	STYLE 131	43
W01-358-0133	STYLE 116	46
W01-358-0134	STYLE 19	49
W01-358-0135	STYLE 113	51
W01-358-0138	STYLE 274 (formerly 20)	63
W01-358-0142	STYLE 26	62
W01-358-0147	STYLE 138-1.5	57
W01-358-0150	STYLE 113-1	52
W01-358-0205	STYLE 203	71
W01-358-0213	STYLE 21	67
W01-358-0226	STYLE 22	65
W01-358-0231	STYLE 128	51
W01-358-0259	STYLE 22-1.5	66
W01-358-0286	STYLE 16	42
W01-358-0305	STYLE 20-2	64
W01-358-0319	STYLE 268 (formerly 25)	59
W01-358-0324	STYLE 324	80
W01-358-0730	STYLE 1T15M-6	98
W01-358-0987	STYLE 320	81
W01-358-1021	STYLE 148-1	58
W01-358-1023	STYLE 348-3	83
W01-358-1026	STYLE 126	56
W01-358-1098	STYLE 39	77
W01-358-1099	STYLE 39	77
W01-358-2132	STYLE 1T19L-11	101
W01-358-3400	STYLE 224	61
W01-358-3403	STYLE 224	61
W01-358-3407	STYLE 224	61
W01-358-5126	STYLE 200	73
W01-358-5135	STYLE 121	55
W01-358-5305	STYLE 1T14C-1	89
W01-358-5306	STYLE 1T14C-1	89
W01-358-5307	STYLE 1T14C-1	89
W01-358-5310	STYLE 1T14C-1	89
W01-358-5311	STYLE 1T14C-1	89
W01-358-5405	STYLE 1T14C-3	90
W01-358-5708	STYLE 1T14C-7	91
W01-358-5712	STYLE 1T14C-7	91
W01-358-5743	STYLE 1T28C-7	91
W01-358-6800	STYLE 21-2	68
W01-358-6801	STYLE 21-2	68
W01-358-6810	STYLE 233-2	69
W01-358-6811	STYLE 233-2	69
W01-358-6819	STYLE 233-2	69
W01-358-6833	STYLE 267-1.5 (formerly 255-1.5)	60
W01-358-6896	STYLE 19-.75	50
W01-358-6900	STYLE 274 (formerly 20)	63
W01-358-6901	STYLE 274 (formerly 20)	63
W01-358-6910	STYLE 274 (formerly 20)	63
W01-358-6911	STYLE 274 (formerly 20)	63
W01-358-6923	STYLE 274 (formerly 20)	63

ORDER NUMBER	STYLE NUMBER	SEE PAGE
W01-358-6947	STYLE 20-2	64
W01-358-6951	STYLE 20-2	64
W01-358-6952	STYLE 20-2	64
W01-358-6955	STYLE 267-1.5 (formerly 255-1.5)	60
W01-358-6956	STYLE 267-1.5 (formerly 255-1.5)	60
W01-358-6996	STYLE 16	42
W01-358-7001	STYLE 16	42
W01-358-7008	STYLE 19	49
W01-358-7009	STYLE 19	49
W01-358-7011	STYLE 19	49
W01-358-7012	STYLE 19	49
W01-358-7019	STYLE 333	78
W01-358-7023	STYLE 19	49
W01-358-7025	STYLE 268 (formerly 25)	59
W01-358-7030	STYLE 268 (formerly 25)	59
W01-358-7035	STYLE 268 (formerly 25)	59
W01-358-7039	STYLE 19-.75	50
W01-358-7040	STYLE 19-.75	50
W01-358-7042	STYLE 19-.75	50
W01-358-7043	STYLE 19-.75	50
W01-358-7047	STYLE 268 (formerly 25)	59
W01-358-7080	STYLE 202	62
W01-358-7091	STYLE 113-1	52
W01-358-7092	STYLE 113-1	52
W01-358-7094	STYLE 113-1	52
W01-358-7101	STYLE 113	51
W01-358-7103	STYLE 113	51
W01-358-7104	STYLE 113	51
W01-358-7109	STYLE 113	51
W01-358-7110	STYLE 113	51
W01-358-7119	STYLE 202	62
W01-358-7139	STYLE 21	67
W01-358-7143	STYLE 21	67
W01-358-7144	STYLE 21	67
W01-358-7145	STYLE 21	67
W01-358-7146	STYLE 21	67
W01-358-7180	STYLE 22	65
W01-358-7184	STYLE 22	65
W01-358-7185	STYLE 22	65
W01-358-7191	STYLE 28	70
W01-358-7192	STYLE 28	70
W01-358-7194	STYLE 28	70
W01-358-7197	STYLE 121	55
W01-358-7201	STYLE 29	72
W01-358-7203	STYLE 29	72
W01-358-7205	STYLE 29	72
W01-358-7208	STYLE 205	67
W01-358-7221	STYLE 205	67
W01-358-7224	STYLE 205	67
W01-358-7225	STYLE 203	71
W01-358-7227	STYLE 203	71
W01-358-7228	STYLE 218	71
W01-358-7230	STYLE 215 (formerly 211)	74
W01-358-7237	STYLE 205	67
W01-358-7239	STYLE 207	72
W01-358-7242	STYLE 207	72
W01-358-7244	STYLE 201	70
W01-358-7250	STYLE 210	65
W01-358-7251	STYLE 210	65
W01-358-7258	STYLE 210	65
W01-358-7271	STYLE 28	70
W01-358-7272	STYLE 121	55
W01-358-7273	STYLE 203	71
W01-358-7274	STYLE 323	80
W01-358-7275	STYLE 29	72
W01-358-7276	STYLE 320	81
W01-358-7277	STYLE 113-1	52
W01-358-7286	STYLE 312	79
W01-358-7291	STYLE 210	65
W01-358-7301	STYLE 215 (formerly 211)	74
W01-358-7302	STYLE 215 (formerly 211)	74
W01-358-7304	STYLE 321 (formerly 319)	82
W01-358-7306	STYLE 321 (formerly 319)	82
W01-358-7319	STYLE 321 (formerly 319)	82

ORDER NUMBER	STYLE NUMBER	SEE PAGE
W01-358-7324	STYLE 320	81
W01-358-7325	STYLE 26	62
W01-358-7327	STYLE 26	62
W01-358-7333	STYLE 26	62
W01-358-7400	STYLE 22	64
W01-358-7431	STYLE 22	64
W01-358-7442	STYLE 22-1.5	66
W01-358-7443	STYLE 22-1.5	66
W01-358-7444	STYLE 22-1.5	66
W01-358-7451	STYLE 110	45
W01-358-7458	STYLE 115	48
W01-358-7459	STYLE 115	48
W01-358-7460	STYLE 115	48
W01-358-7465	STYLE 115	48
W01-358-7469	STYLE 115	48
W01-358-7473	STYLE 22-1.5	66
W01-358-7477	STYLE 119	54
W01-358-7478	STYLE 119	54
W01-358-7480	STYLE 22-1.5	66
W01-358-7484	STYLE 110	45
W01-358-7558	STYLE 233-2	69
W01-358-7561	STYLE 116	46
W01-358-7564	STYLE 116	46
W01-358-7568	STYLE 116	46
W01-358-7592	STYLE 160	44
W01-358-7598	STYLE 116-1	47
W01-358-7600	STYLE 117	46
W01-358-7602	STYLE 117	46
W01-358-7605	STYLE 116-1	47
W01-358-7606	STYLE 117	46
W01-358-7649	STYLE 124	48
W01-358-7650	STYLE 124	48
W01-358-7726	STYLE 126	56
W01-358-7727	STYLE 126	56
W01-358-7729	STYLE 131	43
W01-358-7731	STYLE 131	43
W01-358-7734	STYLE 138-1.5	56
W01-358-7737	STYLE 138-1.5	57
W01-358-7742	STYLE 131	43
W01-358-7751	STYLE 160	44
W01-358-7752	STYLE 160	44
W01-358-7760	STYLE 312	79
W01-358-7761	STYLE 312	79
W01-358-7772	STYLE 200	73
W01-358-7775	STYLE 200	73
W01-358-7781	STYLE 233-2	69
W01-358-7789	STYLE 20-2	64
W01-358-7801	STYLE 313	77
W01-358-7802	STYLE 313	77
W01-358-7807	STYLE 313	77
W01-358-7808	STYLE 313	77
W01-358-7811	STYLE 313	77
W01-358-7815	STYLE 39	77
W01-358-7823	STYLE 323	80
W01-358-7829	STYLE 324	80
W01-358-7830	STYLE 333	78
W01-358-7838	STYLE 333	78
W01-358-7842	STYLE 333	78
W01-358-7845	STYLE 333	78
W01-358-7849	STYLE 333	78
W01-358-7900	STYLE 313	77
W01-358-7902	STYLE 29	72
W01-358-7912	STYLE 215 (formerly 211)	74
W01-358-7914	STYLE 312	79
W01-358-7919	STYLE 321 (formerly 319)	82
W01-358-7921	STYLE 323	80
W01-358-7925	STYLE 28	70
W01-358-7926	STYLE 314	79
W01-358-7928	STYLE 210	65
W01-358-7929	STYLE 205	67
W01-358-8003	STYLE 314	79
W01-358-8004	STYLE 314	79
W01-358-8047	STYLE 352	76
W01-358-8048	STYLE 352	76

ORDER NUMBER	STYLE NUMBER	SEE PAGE
W01-358-8149	STYLE 128	51
W01-358-8150	STYLE 128	51
W01-358-8151	STYLE 128	51
W01-358-8152	STYLE 128	51
W01-358-8157	STYLE 153-2	53
W01-358-8158	STYLE 153-2	53
W01-358-8160	STYLE 128-1	52
W01-358-8162	STYLE 128-1	52
W01-358-9030	STYLE 1T15M-0	95
W01-358-9031	STYLE 1T15M-0	95
W01-358-9034	STYLE 1T15M-0	95
W01-358-9035	STYLE 1T15M-0	95
W01-358-9036	STYLE 1T15M-0	95
W01-358-9038	STYLE 1T15M-0	95
W01-358-9042	STYLE 1T15M-2	96
W01-358-9049	STYLE 1T15LP-3 (formerly 1T15S-6)	93
W01-358-9051	STYLE 1T15LP-3 (formerly 1T15S-6)	93
W01-358-9053	STYLE 1T15M-2	96
W01-358-9054	STYLE 1T15M-2	96
W01-358-9056	STYLE 1T15M-4	97
W01-358-9057	STYLE 1T15M-4	97
W01-358-9060	STYLE 1T15M-4	97
W01-358-9062	STYLE 1T15M-4	97
W01-358-9079	STYLE 1T15M-6	98
W01-358-9088	STYLE 1T15M-6	98
W01-358-9089	STYLE 1T15M-6	98
W01-358-9096	STYLE 1T15M-6	98
W01-358-9099	STYLE 1T15M-2	96
W01-358-9104	STYLE 1T15M-9	99
W01-358-9106	STYLE 1T15M-9	99
W01-358-9108	STYLE 1T15M-9	99
W01-358-9117	STYLE 1T15M-9	99
W01-358-9148	STYLE 1T19L-7	100
W01-358-9149	STYLE 1T19L-7	100
W01-358-9153	STYLE 1T19L-11	101
W01-358-9155	STYLE 1T19L-11	101
W01-358-9156	STYLE 1T19L-11	101
W01-358-9160	STYLE 1T19L-7	100
W01-358-9162	STYLE 1T19L-11	101
W01-358-9165	STYLE 1T19L-7	100
W01-358-9172	STYLE 1T19L-7	100
W01-358-9400	STYLE 1T15T-1	92
W01-358-9401	STYLE 1T15T-1	92
W01-358-9402	STYLE 1T15T-1	92
W01-358-9414	STYLE 1T15L-4	94
W01-358-9526	STYLE 328	81
W01-358-9528	STYLE 328	81
W01-358-9529	STYLE 21-2	68
W01-358-9531	STYLE 21-2	68
W01-358-9601	STYLE 148-1	58
W01-358-9602	STYLE 248-2	75
W01-358-9603	STYLE 348-3	83
W01-410-7517	STYLE 116-1	46
W01-606-7025	STYLE 268 (formerly 25)	59
W01-606-7115	STYLE 115	48
W01-753-7113	STYLE 113	51
W01-753-7114	STYLE 113	51
W02-358-3000	STYLE 1M1A-0	38
W02-358-3001	STYLE 1M1A-0	38
W02-358-3002	STYLE 2M1A	40
W02-358-3003	STYLE 1M1A-1	39
W02-358-3004	STYLE 2M1A	40
W02-358-3005	STYLE 1M1A-0	38
W02-358-3008	STYLE 2M2A	41
W02-358-4004	STYLE 4004	84
W02-358-7002	STYLE 7002	85
W02-358-7010	STYLE 7010	86
W02-358-7012	STYLE 7012	87
W26-358-9025	STYLE 110/70	88



# AIRSTROKE™ ACTUATOR DESIGN PARAMETER WORKSHEET

1. FORCE REQUIRED:

\_\_\_\_\_

2. STROKE REQUIRED:

\_\_\_\_\_

3. AVAILABLE AIR PRESSURE:

\_\_\_\_\_

4. ANGLE OF MOTION (PLEASE SKETCH):

6. ENVIRONMENTAL CONDITIONS:

\_\_\_\_\_

\_\_\_\_\_

7. CYCLE RATE:

\_\_\_\_\_

8. RESPONSE TIME REQUIRED:

\_\_\_\_\_

SPECIAL REQUIREMENTS:

\_\_\_\_\_

\_\_\_\_\_

\_\_\_\_\_

\_\_\_\_\_

\_\_\_\_\_

\_\_\_\_\_

\_\_\_\_\_

\_\_\_\_\_

\_\_\_\_\_

5. LATERAL SPACE AVAILABLE FOR  
AIRSTROKE ACTUATOR(S):

\_\_\_\_\_

DATE \_\_\_\_\_

PLEASE SKETCH WITH DIMENSIONS

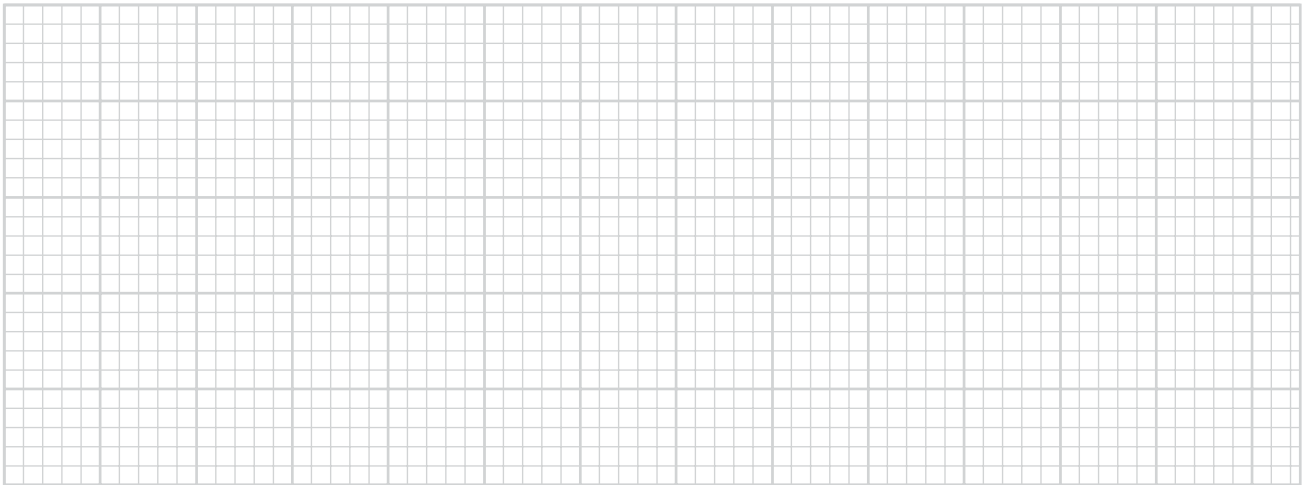

REMARKS

\_\_\_\_\_

\_\_\_\_\_

\_\_\_\_\_

\_\_\_\_\_

NAME \_\_\_\_\_

COMPANY \_\_\_\_\_

ADDRESS \_\_\_\_\_

CITY/COUNTRY/CODE \_\_\_\_\_

TELEPHONE \_\_\_\_\_

Please return to your local stocking distributor, or send directly to:  
Firestone Industrial Products Company, 250 W. 96th Street, Indianapolis, IN 46260 U.S.A.  
Phone: 1-800-888-0650 • Email: NAIndustrial@firestoneip.com

PLEASE CUT ALONG DOTTED LINE









# INDEX

## STYLE NUMBER TO PAGE NUMBER

TWO PLY STYLE NO.	HIGH STRENGTH STYLE NO.	SEE PAGE
----------------------	----------------------------	----------

### SINGLE CONVOLUTION

16		42
131		43
160		44
110		45
116	117	46
116-1		47
115	124	48
19		49
19-75		50
113	128	51
113-1	128-1	52
153-2		53
119		54
121		55
126		56
138-1.5		57
	148-1	58

### DOUBLE CONVOLUTION

268		59
267-1.5		60
224		61
26		62
274	202	63
20-2		64
22	210	65
22-1.5		66
21	205	67
21-2		68
233-2		69
28	201	70
203	218	71
29	207	72
200		73
215		74
	248-2	75

TWO PLY STYLE NO.	HIGH STRENGTH STYLE NO.	SEE PAGE
----------------------	----------------------------	----------

### TRIPLE CONVOLUTION

352		76
313	39	77
333		78
312	314	79
323	324	80
320	328	81
	321	82
	348-3	83

### REVERSIBLE SLEEVE

4004		84
7002		85
7010		86
7012		87
110/70		88
1T14C-1		89
1T14C-3		90
1T14C-7	1T28F-8	91
1T15T-1		92
1T15LP-3		93
1T15L-4		94
1T15M-0		95
1T15M-2		96
1T15M-4		97
1T15M-6		98
1T15M-9		99
1T19L-7		100
1T19L-11		101

### SHAPED SLEEVE

1M1A		38
1M1A-1		39
2M1A		40
2M2A		41

### POLYACTUATOR

50-P-10		35
70-P-13		36
120-P-25		37

# TYPICAL APPLICATIONS

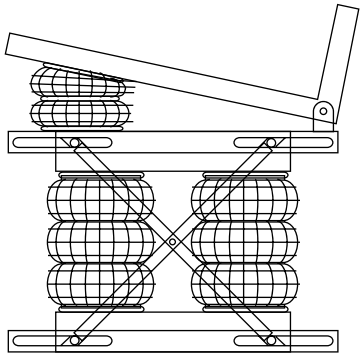

**SCISSORS LIFT AND TILT TABLE**

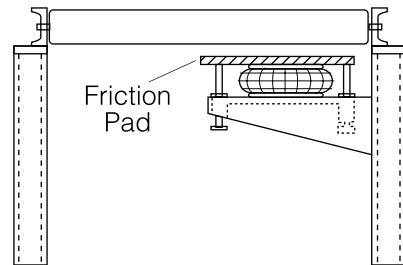

**ROLLER FRICTION BRAKE**

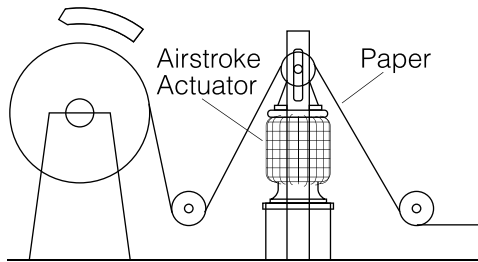

**WEB TENSIONING DEVICE**

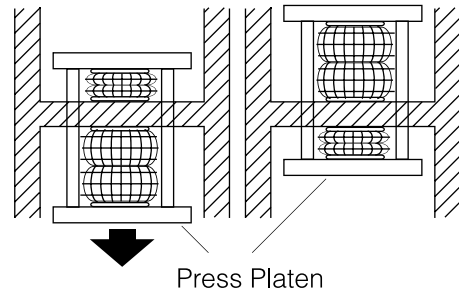

**FORMING PRESS**

**DISTRIBUTED BY:**

**Firestone**  
*World's Number 1  
Air Spring.*

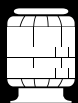

FIRESTONE INDUSTRIAL PRODUCTS COMPANY

[www.firestoneip.com](http://www.firestoneip.com)

800.888.0650

**PLEASE NOTE:**

The information contained in this publication is intended to provide a general guide to the characteristics and application so of these products. The material, herein, was developed through engineering design and development, testing and actual applications and is believed to be reliable and accurate. Firestone, however, makes no warranty, express or implied, of this information. Anyone making use of this data does so at his/her own risk and assumes all liability resulting from such use. It is suggested that competent professional assistance be employed for specific applications.